

INSTRUCTION MANUAL
Geodetic Measurement Station

GM-60 series

HOW TO READ THIS MANUAL

Thank you for selecting the GM-60 series.

- Please read this Operator's manual carefully, before using this product.
- GM has a function to output data to a connected host computer. Command operations from a host computer can also be performed. For details, refer to "Communication manual" and ask your local dealer.
- The specifications and general appearance of the instrument are subject to change without prior notice and without obligation by TOPCON CORPORATION and may differ from those appearing in this manual.
- The content of this manual is subject to change without notice.
- Some of the diagrams shown in this manual may be simplified for easier understanding.
- Always keep this manual in a convenient location and read it when necessary.
- This manual is protected by copyright and all rights are reserved by TOPCON CORPORATION.
- Except as permitted by Copyright law, this manual may not be copied, and no part of this manual may be reproduced in any form or by any means.
- This manual may not be modified, adapted or otherwise used for the production of derivative works.

Symbols

The following conventions are used in this manual.



: Indicates precautions and important items which should be read before operations.



: Indicates the chapter title to refer to for additional information.



: Indicates supplementary explanation.

Notes regarding manual style

- Except where stated, "GM" means GM-60 series in this manual.
- Except where stated, screens and illustrations are explained using instruments with a display on both sides and *Bluetooth* enabled.
- Learn basic key operations in "1. NOMENCLATURE AND FUNCTIONS" before you read each measurement procedure.
- Measurement procedures are based on continuous measurement. Some information about procedures when other measurement options are selected can be found in "Note" (**Note**).
- *Bluetooth*[®] is a registered trademark of Bluetooth SIG, Inc.
- KODAK is a registered trademark of Eastman Kodak Company.
- All other company and product names featured in this manual are trademarks or registered trademarks of each respective organization.



Li-ion CONTAINS Li-ion BATTERY.
MUST BE RECYCLED OR DISPOSED OF PROPERLY.



JSIMA : This is the mark of the Japan Surveying Instruments Manufacturers Association.



PRECAUTIONS FOR SAFE OPERATION

For the safe use of the product and prevention of injury to operators and other persons as well as prevention of property damage, items which should be observed are indicated by an exclamation point within a triangle used with WARNING and CAUTION statements in this instruction manual.

The definitions of the indications are listed below. Be sure you understand them before reading the manual's main text.









Definition of Indication

 WARNING	Ignoring this indication and making an operation error could possibly result in death or serious injury to the operator.
 CAUTION	Ignoring this indication and making an operation error could possibly result in minor injury or property damage.



-  This symbol indicates items for which caution (hazard warnings inclusive) is urged. Specific details are printed in or near the symbol.
-  This symbol indicates items which are prohibited. Specific details are printed in or near the symbol.
-  This symbol indicates items which must always be performed. Specific details are printed in or near the symbol.

General

Warning













-  Do not use the unit in areas exposed to high amounts of dust or ash, in areas where there is inadequate ventilation, or near combustible materials. An explosion could occur.
-  Do not perform disassembly or rebuilding. Fire, electric shock, burns, or hazardous radiation exposure could result.
-  Never look at the sun through the telescope. Loss of eyesight could result.
-  Do not look at reflected sunlight from a prism or other reflecting object through the telescope. Loss of eyesight could result.
-  Direct viewing of the sun during sun observation will cause loss of eyesight. Use solar filter (option) for sun observation.
-  When securing the instrument in the carrying case, make sure to set all the locks. Failure to do so could result in the instrument falling out while being carried, causing injury.
-  Do not place the instrument in a damaged case or in a case with a damaged belt. The case or instrument could be dropped and cause injury.
-  Secure handle to main unit. Failure to properly secure the handle could result in the unit falling off while being carried, causing injury.

Caution

-  Do not use the carrying case as a footstool. The case is slippery and unstable so a person could slip and fall off it.
-  Do not wield or throw the plumb bob. A person could be injured if struck.
-  Tighten the adjustment tribrach clamp securely. Failure to properly secure the clamp could result in the tribrach falling off while being carried, causing injury.

Power Supply

Warning





-  Do not disassemble or rebuild the battery or the battery charger, nor expose to heavy shocks or vibration. Sparking, fire, electric shock or burns could result.
-  Do not short circuit. Heat or ignition could result.
-  Do not place articles such as clothing on the battery charger while charging batteries. Sparks could be induced, leading to fire.
-  Do not use voltage other than the specified power supply voltage. Fire or electrical shock could result.
-  Do not use batteries other than those designated. An explosion could occur, or abnormal heat generated, leading to fire.
-  Do not use damaged power cords, plugs or loose outlets. Fire or electric shock could result.
-  Do not use power cords other than those designated. Fire could result.
-  Use only the specified battery charger to recharge batteries. Other chargers may be of different voltage rating or polarity, causing sparking which could lead to fire or burns.
-  Do not use the battery or charger for any other equipment or purpose. Fire or burns caused by ignition could result.
-  Do not heat or throw batteries or chargers into fire. An explosion could occur, resulting in injury.
-  To prevent shorting of the battery in storage, apply insulating tape or equivalent to the terminals. Otherwise shorting could occur, resulting in fire or burns.
-  Do not use the battery or the battery charger if its terminals are wet. Resultant poor contact or shorting could lead to fire or burns.
-  Do not connect or disconnect power supply plugs with wet hands. Electric shock could result.

Caution

-  Do not touch liquid leaking from batteries. Harmful chemicals could cause burns or blisters.

Tripod

Caution

-  When mounting the instrument to the tripod, tighten the centering screw securely. Failure to tighten the screw properly could result in the instrument falling off the tripod, causing injury.
-  Tighten securely the leg fixing screws of the tripod on which the instrument is mounted. Failure to tighten the screws could result in the tripod collapsing, causing injury.
-  Do not carry the tripod with the tripod shoes pointed at other persons. A person could be injured if struck by the tripod shoes.
-  Keep hands and feet away from the tripod shoes when fixing the tripod in the ground. A hand or foot stab wound could result.
-  Tighten the leg fixing screws securely before carrying the tripod. Failure to tighten the screws could lead to the tripod legs extending, causing injury.

Bluetooth Wireless technology



Warning



Do not use within the vicinity of hospitals. Malfunction of medical equipment could result.



Use the instrument at a distance of at least 22 cm from anyone with a cardiac pacemaker. Otherwise, the pacemaker may be adversely affected by the electromagnetic waves produced and cease to operate as normal.



Do not use onboard aircraft. The aircraft instrumentation may malfunction as a result.



Do not use within the vicinity of automatic doors, fire alarms and other devices with automatic controls as the electromagnetic waves produced may adversely affect operation resulting in an accident.

PRECAUTIONS

Before starting work or operation, be sure to check that the instrument is functioning correctly with normal performance.

Charging Battery

- Be sure to charge the battery within the charging temperature range.
Charging temperature range: 0 to 40°C
- Use only the specified battery and the battery charger. Failures caused by using other batteries and battery chargers are out of warranty including the main unit.

Warranty policy for Battery

- Battery is an expendable item. The decline in retained capacity depending on the repeated charging/ discharging cycle is out of warranty.

Transportation of this product

- When transporting or carrying this product, use a cushion or other buffer to protect it from shocks and vibration wherever possible. Heavy shocks and vibration may affect the performance of this product or cause malfunction.
- This product contains a lithium-ion battery. Therefore, there are handling restrictions when transporting it by air. When transporting the product by air as carry-on or checked baggage, follow the regulations of your airline.

Before recycling or disposing of rechargeable batteries

Take the following measures to prevent smoke or fire caused by a short circuit in rechargeable batteries.

- Insert the rechargeable batteries into the instrument and use them up completely.
- Insulate the terminals of rechargeable batteries with tape or similar material.

Telescope

- Aiming the telescope at the sun will cause internal damage to the instrument. Use the solar filter when observing the sun.

 "20. SPECIAL ACCESSORIES"

Tribrach Clamp and Handle

- When the instrument is shipped, the tribrach clamp is held firmly in place with a locking screw to prevent the instrument from shifting on the tribrach. Before using the instrument the first time, loosen this screw with a precision screwdriver. And before transporting it, tighten the locking screw to fasten the tribrach clamp in place so that it will not shift on the tribrach.
- The handle of the instrument can be removed. When operating the instrument with the handle attached, always make sure that the handle is securely fixed to the instrument body with the handle locks.

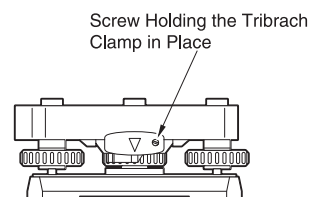

Precautions concerning water and dust resistance

GM conforms to IP66 specifications for waterproofing and dust resistance when the battery cover and external interface hatch are closed and connector caps are attached correctly.

- Be sure to close the battery cover and external interface hatch, and correctly attach the connector caps to protect the GM from moisture and dust particles.
The specification grade for water proofing and dust resistance is not guaranteed when using USB connector.
- Make sure that moisture or dust particles do not come in contact with the inside of the battery cover, terminal or connectors. Contact with these parts may cause damage to the instrument.
- Make sure that the inside of the carrying case and the instrument are dry before closing the case. If moisture is trapped inside the case, it may cause the instrument to rust.
- If there is a crack or deformation in the rubber packing for the battery cover or external interface hatch, stop using and replace the packing.
- To retain the waterproof property, it is recommended that you replace the rubber packing once every two years. To replace the packing, contact your local dealer.

The Lithium Battery

- This instrument contains lithium battery. It lasts for approximately 5 years of normal use and storage (Temperature = 20°C, humidity = about 50%), but its lifetime may be shorter depending on circumstances. To replace the lithium battery, contact your local dealer.

Vertical and horizontal clamps

- Always fully release the vertical/horizontal clamps when rotating the instrument or telescope. Rotating with clamp(s) partially applied may adversely affect accuracy.

Tribrach

- Always use the tribrach provided. During a traverse observation, it is recommended to use the same type of tribrach for the target as well for accurate observations.

Backing up data

- Data should be backed up (transferred to an external device etc.) on a regular basis to prevent data loss.

Other precautions

- Close the external interface hatch and battery cover before starting measurement. Otherwise, ambient light entering the USB port may adversely affect measurement results.
- If the GM is moved from a warm place to an extremely cold place, internal parts may contract and make the keys difficult to operate. This is caused by cold air trapped inside the hermetically sealed casing. If the keys do not depress, open the battery cover to resume normal functionality. To prevent the keys from becoming stiff, remove the connector caps before moving the GM to a cold place.
- Never place the GM directly on the ground. Sand or dust may cause damage to the screw holes or the centering screw on the base plate.
- Do not aim the telescope directly at the sun. Also, attach the lens cap to the telescope when not in use. Use the Solar filter to avoid causing internal damage to the instrument when observing the sun.
 "20. SPECIAL ACCESSORIES"
- Do not perform vertical rotation of the telescope when using the lens hood, diagonal eyepiece, or solar filter. Such accessories may strike the instrument causing damage.
- Protect the GM from heavy shocks or vibration.
- Never carry the GM on the tripod to another site.
- Turn the power off before removing the battery.
- When placing the GM in its case, first remove its battery and place it in the case in accordance with the layout plan.
- Consult your local dealer before using the instrument under special conditions such as long periods of continuous use or high levels of humidity. In general, special conditions are treated as being outside the scope of the product warranty.

Maintenance

- Wipe off moisture completely if the instrument gets wet during survey work.
- Always clean the instrument before returning it to the case. The lens requires special care. First, dust it off with the lens brush to remove tiny particles. Then, after providing a little condensation by breathing on the lens, wipe it with the silicon cloth.
- If the display unit is dirty, carefully wipe it with a soft, dry cloth. To clean other parts of the instrument or the carrying case, lightly moisten a soft cloth in a mild detergent solution. Wring out excess water until the cloth is slightly damp, then carefully wipe the surface of the unit. Do not use any alkaline cleaning solutions, alcohol, or any other organic solvents on the instrument or display unit.
- Store the GM in a dry room where the temperature remains fairly constant.
- Check the tripod for loose fit and loose screws.
- If any trouble is found on the rotatable portion, screws or optical parts (e.g. lens), contact your local dealer.
- When the instrument is not used for a long time, check it at least once every 3 months.
☞ "18. CHECKS AND ADJUSTMENTS"
- When removing the GM from the carrying case, never pull it out by force. The empty carrying case should be closed to protect it from moisture.
- Check the GM for proper adjustment periodically (1 or 2 times per year) to maintain the instrument accuracy.

Bluetooth Wireless Technology

- *Bluetooth* function may not be built in depending on telecommunications regulations of the country or the area where the instrument is purchased. Contact your local dealer for the details.
- Use of this technology must be authorized according to telecommunications regulations of the country where the instrument is being used. Contact your local dealer in advance. ☞ "25. REGULATIONS"
- TOPCON CORPORATION is not liable for the content of any transmission nor any content related thereto. When communicating important data, run tests beforehand to ascertain that communication is operating normally.
- Do not divulge the content of any transmission to any third party.

Radio interference when using Bluetooth technology

Bluetooth communication with the GM uses the 2.4 GHz frequency band. This is the same band used by the devices described below. As a result, using the GM within proximity to these devices may result in interference causing communication failure or reduction of transmission speed.

- Industrial, scientific, and medical (ISM) equipment such as microwaves and pacemakers.
- Portable premises radio equipment (license required) used in factory production lines etc.
- Portable specified low-power radio equipment (license-exempt)
- Wireless devices (*Bluetooth* devices)

Although a radio station license is not required for this instrument, bear in mind the following points when using *Bluetooth* technology for communication.

- **Do not use the GM in proximity to microwaves.**
 - Microwave ovens can cause significant interference resulting in communication failure. Perform communication at a distance of 3 m or more from microwave ovens.
- **Regarding portable premises radio equipment and portable specified low-power radio equipment:**
 - Before starting transmission, check that operation will not take place within the vicinity of portable premises radio equipment or specified low-power radio equipment.
 - In the case that the instrument causes radio interference with portable premises radio equipment, terminate the connection immediately and take measures to prevent further interference (e.g. connect using an interface cable).
 - In the case that the instrument causes radio interference with portable specified low-power radio equipment, contact your local dealer.
- **When using *Bluetooth* function in proximity to wireless devices (*Bluetooth* devices/Wireless LAN devices), turn off all wireless LAN devices not being used.**
 - Interference may result, causing transmission speed to slow or even disrupting the connection completely.

● **Refrain from using the GM in proximity to televisions and radios.**

- Televisions and radios use a different frequency band to *Bluetooth* communications. However, even if the GM is used within proximity to the above equipment with no adverse effects with regard to *Bluetooth* communication, moving wireless devices (*Bluetooth* devices/Wireless devices) including the GM closer to said equipment may result in electronic noise in sound or images, adversely affecting the performance of televisions and radios.

Precautions regarding transmission

● **For best results**

- The usable range becomes shorter when obstacles block the line of sight, or devices such as PDAs or computers are used. Wood, glass and plastic will not impede communication but the usable range becomes shorter. Moreover, wood, glass and plastic containing metal frames, plates, foil and other heat shielding elements as well as coatings containing metallic powders may adversely affect *Bluetooth* communication and concrete, reinforced concrete, and metal will render it impossible.
- Use a vinyl or plastic cover to protect the instrument from rain and moisture. Metallic materials should not be used.

● **Reduced range due to atmospheric conditions**

- The radio waves used by the GM may be absorbed or scattered by rain, fog, and moisture from the human body with the limit of usable range becoming lower as a result. Similarly, usable range may also shorten when performing communication in wooded areas. Moreover, as wireless devices lose signal strength when close to the ground, perform communication at as high a position as possible.



- TOPCON CORPORATION cannot guarantee full compatibility with all *Bluetooth* products on the market.

Export Restrictions

These commodities, technology or software were exported in accordance with applicable export control laws and regulations. Diversion contrary to those laws and regulations, as well as the export laws and regulations of any countries of reexport, is prohibited.

In consideration for its purchase of commodities, technology or software from Topcon, Purchaser agrees that it will determine any license requirements to export the items and, as applicable, to reexport or transfer the items, obtain any license or other official authorization, and carry out any customs formalities for the export or reexport of the items. Purchaser agrees that it will not export, reexport or transfer the commodities, technology or software to **Cuba, Iran, North Korea, Syria, Russia, Belarus, the Crimea Region of Ukraine and/or the regions of Ukraine referred to as the Donetsk People's Republic (DNR) and the Luhansk People's Republic (LNR)** without a license or other authorization from all applicable export control authorities. (The above prohibited destinations list is based on the regulation as of January 1, 2023. And the forgoing list of prohibited destinations is subject to change by export control authorities without notice, therefore, Purchaser should check the latest websites of all applicable export control authorities prior to the physical export, reexport or transfer of any Topcon items.) It is also unlawful to receive, use, transfer, or reexport these items to persons on all applicable restricted party lists. See, e.g.,

<http://www.bis.doc.gov/index.php/policy-guidance/lists-of-parties-of-concern> and

https://www.eeas.europa.eu/eeas/european-union-sanctions_en, and

<https://www.meti.go.jp/policy/anpo/englishpage.html>

where prohibited, or to use these items in activities involving missiles or unmanned air vehicles, nuclear explosive devices or nuclear propulsion projects, chemical or biological weapons which are regulated as WMD (Weapons of Mass Destruction) or any other prohibited end-use. See, e.g.,

<https://www.bis.doc.gov/index.php/documents/regulation-docs/418-part-744-control-policy-end-user-and-end-use-based/file>

Exporting this product (Relating telecommunications regulations)

- When exporting or bringing the product to a overseas, you must comply with the laws and regulations (including but not limited to radio laws, safety standards, EMC (electromagnetic compatibility), etc.) of that country. Contact your local dealer in advance.
- Depending on the country or region, bringing in the product may be prohibited by the laws and regulations. It is the customer's responsibility to bring the product into the overseas.

Exceptions from Responsibility

- The manufacturer, or its representatives, assumes no responsibility for any damage, or loss of profits (change of data, loss of data, loss of profits, an interruption of business etc.) caused by use of the product or an unusable product.
- The manufacturer, or its representatives, assumes no responsibility for any damage, or loss of profits caused by usage different to that explained in this manual.
- The manufacturer, or its representative, assumes no responsibility for any damage, or loss of profits caused by exporting or bringing the product to overseas in a manner contrary to the instructions in this manual.
- The manufacturer, or its representatives, assumes no responsibility for consequential damage, or loss of profits due to heavy rain, strong wind, high-temperature and humidity, or storing or use of the product under unusual conditions.
- Product failures caused by rebuilding are out of warranty.
- Cautions and warnings included in this manual do not cover all the possible events.

LASER SAFETY INFORMATION

GM is classified as the following class of Laser Product according to IEC Standard Publication 60825-1 Ed.3.0: 2014 and United States Government Code of Federal Regulation FDA CDRH 21CFR Part 1040.10 and 1040.11 (Complies with FDA performance standards for laser products except for deviations pursuant to Laser Notice No.56, dated May 8, 2019.)

Device		Laser class
EDM device in objective lens	Light beam used for measurement (When reflectorless measurement is selected in Config mode)	Class 3R
	Light beam used for measurement (When prism or reflective sheet is selected as target in Config mode)	Class 1
	Laser-pointer	Class 3R
Laser plummet (option) *1		Class 2

*1: Laser plummet is available as a factory option depending on the country or the area where the instrument is purchased.



- EDM device is classified as Class 3R Laser Product when reflectorless measurement is selected. When the prism or reflective sheet is selected in Config mode as target, the output is equivalent to the safer class 1.

Warning

- Use of controls or adjustments or performance of procedures other than those specified herein may result in hazardous radiation exposure.
- Follow the safety instructions on the labels attached to the instrument as well as in this manual to ensure safe use of this laser product.

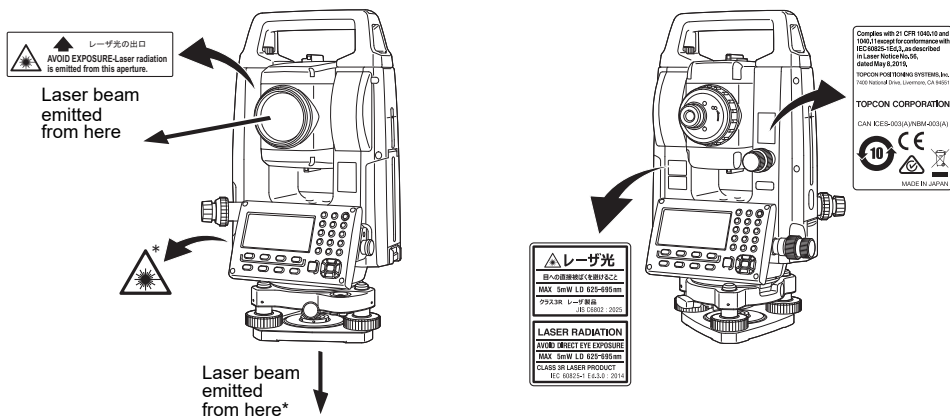

*: only for instruments with laser plummet (option)

- Never intentionally point the laser beam at another person. The laser beam is injurious to the eyes and skin. If an eye injury is caused by exposure to the laser beam, seek immediate medical attention from a licensed ophthalmologist.
- Do not look directly into the laser beam source. Doing so could cause permanent eye damage.
- Do not stare at the laser beam. Doing so could cause permanent eye damage.
- Never look at the laser beam through a telescope, binoculars or other optical instruments. Doing so could cause permanent eye damage.
- Sight targets so that laser beam does not stray from them.

Caution

- Perform checks at start of work and periodic checks and adjustments with the laser beam emitted under normal conditions.
- When the instrument is not being used, turn OFF the power.
- When disposing of the instrument, destroy the battery connector so that the laser beam cannot be emitted.
- Operate the instrument with due caution to avoid injuries that may be caused by the laser beam unintentionally striking a person in the eye. Avoid setting the instrument at heights at which the path of the laser beam may strike pedestrians or drivers at head height.
- Never point the laser beam at mirrors, windows or surfaces that are highly reflective. The reflected laser beam could cause serious injury.
- After using the Laser-pointer function, be sure to turn OFF the emission of the laser beam.
- Only those who have been received training as per the following items shall use this product.
 - Read the Operator's manual for usage procedures for this product.
 - Hazardous protection procedures (read this chapter).
 - Requisite protective gear (read this chapter).
 - Accident reporting procedures (stipulate procedures beforehand for transporting the injured and contacting physicians in case there are laser induced injuries).
- Persons working within the range of the laser beam are advised to wear eye protection which corresponds to the laser wavelength of the instrument being used. (OD2)
- Areas in which the laser is used should be posted with a standard laser warning sign.

Symbol mark while the laser is emitting

The following symbol mark will appear at the right side of the second line.

TILT SENSOR: [XY-ON]	
X: -0°00'25"	
Y: 0°00'20"	
X-ON XY-ON OFF ---	

Symbol mark

Contents

1 NOMENCLATURE AND FUNCTIONS	1-1
1.1 Nomenclature	1-1
1.2 Display	1-3
1.3 Operating Key	1-4
1.4 Function Key (Soft Key)	1-5
1.5 Starkey mode	1-7
1.6 Serial signal RS-232C connector	1-9
1.7 Bluetooth communication (Only for Bluetooth function built-in models)	1-9
2 PREPARATION FOR MEASUREMENT	2-1
2.1 Power Switch Key ON	2-1
2.2 Battery Power Remaining Display	2-2
2.3 Vertical and Horizontal Angle Tilt Correction	2-3
2.4 How to Enter Alphanumeric Characters	2-5
2.5 Setting Instrument Up for Measurement	2-8
2.5.1 Centering	2-8
2.5.2 Levelling	2-10
2.6 FOCUSING AND TARGET SIGHTING	2-11
3 ANGLE MEASUREMENT	3-1
3.1 Measuring Horizontal Angle Right and Vertical Angle	3-1
3.2 Switching Horizontal Angle Right/Left	3-1
3.3 Measuring from the Required Horizontal Angle	3-2
3.3.1 Setting by Holding the Angle	3-2
3.3.2 Setting a Horizontal Angle from the Keys	3-2
3.4 Vertical Angle Percent Grade(%) Mode	3-3
3.5 Repetition Angle Measurement	3-3
3.6 Buzzer Sounding for Horizontal Angle 90° Increments	3-4
3.7 Compasses (vertical angle)	3-5
4 DISTANCE MEASUREMENT	4-1
4.1 Setting of the Atmospheric Correction	4-2
4.2 Setting of the Correction for Prism Constant	4-2
4.3 Distance Measurement (Continuous Measurement)	4-2
4.4 Distance Measurement (N-time Measurement/Single Measurement)	4-3
4.5 Fine Mode/Tracking Mode/Coarse Mode	4-4
4.6 Stake Out (S.O)	4-5
4.7 Offset Measurement	4-6
4.7.1 Angle Offset	4-7
4.7.2 Distance Offset Measurement	4-9
4.7.3 Plane Offset Measurement	4-11
4.7.4 Column Offset Measurement	4-13
5 COORDINATE MEASUREMENT	5-1
5.1 Setting Coordinate Values of Occupied Point	5-1
5.2 Setting Height of the Instrument	5-2
5.3 Setting Height of Target (Prism Height)	5-2
5.4 Execution of Coordinate Measuring	5-3
6 SPECIAL MODE (Menu Mode)	6-1
6.1 Application Measurement (PROGRAMS)	6-2
6.1.1 Remote Elevation measurement (REM)	6-2
6.1.2 Missing Line Measurement (MLM)	6-5
6.1.3 Setting Z Coordinate of Occupied Point	6-8
6.1.4 Area Calculation	6-11
6.1.5 Point to Line Measurement	6-14
6.2 Setting the GRID FACTOR	6-16
6.3 Setting Illumination of Display and Cross Hairs	6-17
6.4 Setting Mode 1	6-18
6.4.1 Setting Minimum Reading	6-18
6.4.2 Auto Power Off	6-19
6.4.3 Vertical and Horizontal Angle Tilt correction (Tilt ON/OFF)	6-20
6.4.4 Systematic Error of Instrument Correction	6-20

6.4.5	Setting RS-232C communication with external device	6-22
6.4.6	Selecting Communication Port	6-23
6.4.7	Confirming the <i>Bluetooth</i> Device Address (Only for <i>Bluetooth</i> function built-in models)	6-24
6.4.8	Humidity Input ON/OFF Setting	6-25
6.4.9	NP-TRK MODE Setting	6-26
6.4.10	EDM ECO. MODE Setting	6-27
6.4.11	Volume Setting	6-28
6.5	Setting Contrast of Display	6-29
6.6	Displaying Instrument Information	6-29
6.7	Road	6-30
6.7.1	Inputting Start Point	6-31
6.7.2	Inputting Road Data	6-32
6.7.3	Searching Data	6-36
6.7.4	Editing Data	6-36
6.7.5	Setting OCC and BS	6-37
6.7.6	Stake-out Road	6-39
6.7.7	Selecting a File	6-40
6.7.8	Initializing ROAD data	6-40
7	DATA COLLECTION	7-1
7.1	Preparation	7-3
7.1.1	Selecting a File for Data Collection	7-3
7.1.2	Selecting a Coordinate File for Data Collection	7-4
7.1.3	Occupied Point and Backsight Point	7-5
7.2	Operational Procedure of DATA COLLECT	7-7
7.2.1	Searching the recorded data	7-8
7.2.2	Entering PCODE / ID using PCODE Library	7-8
7.2.3	Entering PCODE / ID from the list of PCODE	7-9
7.3	Data Collect Offset Measurement mode	7-10
7.3.1	Angle Offset Measurement	7-10
7.3.2	Distance Offset Measurement	7-12
7.3.3	Plane Offset Measurement	7-14
7.3.4	Column Offset Measurement	7-16
7.4	NEZ Auto Calculation	7-17
7.5	Point to Line Measurement	7-18
7.5.1	To change to the point to line measurement	7-18
7.5.2	Executing a point to line measurement	7-19
7.6	Editing PCODE Library [PCODE INPUT]	7-20
7.7	Setting Parameter of Data Collect [CONFIG.]	7-21
8	LAYOUT	8-1
8.1	Preparation	8-3
8.1.1	Setting the GRID FACTOR	8-3
8.1.2	Selecting Coordinate Data File	8-4
8.1.3	Setting Occupied Point	8-5
8.1.4	Setting Backsight Point	8-7
8.2	Executing a Layout	8-9
8.2.1	Layout of Coordinates of Point to Line	8-11
8.3	Setting a New Point	8-12
8.3.1	Side Shot Method	8-12
8.3.2	Resection Method	8-14
9	MEMORY MANAGER MODE	9-1
9.1	Display Internal Memory Status	9-2
9.2	Searching Data	9-3
9.2.1	Measured Data Searching	9-3
9.2.2	Coordinate Data Searching	9-5
9.2.3	PCODE LIBRARY Searching	9-6
9.3	File Maintenance	9-7
9.3.1	Rename a File	9-8
9.3.2	Searching Data in a File	9-8
9.3.3	Deleting a File	9-9
9.4	Coordinate Data Direct Key Input	9-10
9.4.1	Coordinate data input	9-10

9.4.2 PTL (Point to Line) data input	9-11
9.5 Delete a Coordinate Data from a File	9-12
9.6 Editing PCODE Library	9-13
9.7 Data Communications	9-14
9.7.1 Sending Data	9-14
9.7.2 Loading Data	9-16
9.7.3 Setting Parameter of Data Communications	9-17
9.7.4 Confirming the parameters for <i>Bluetooth</i> communication (Only for <i>Bluetooth</i> function built-in models)	9-18
9.8 Initialization	9-19
10 SETTING THE PRISM CONSTANT VALUE	10-1
11 SET AUDIO MODE	11-1
12 SETTING ATMOSPHERIC CORRECTION	12-1
12.1 Calculation of Atmospheric Correction	12-1
12.2 Setting of Atmospheric Correction Value	12-2
13 CORRECTION FOR REFRACTION AND EARTH CURVATURE ...	13-1
13.1 Distance Calculation Formula	13-1
14 POWER SOURCE AND CHARGING	14-1
14.1 Battery Charging	14-1
14.2 Installing/Removing the Battery	14-2
15 USING USB FLASH DRIVE	15-1
15.1 Inserting the USB flash drive	15-1
16 DETACH/ATTACH OF TRIBRACH	16-1
17 SELECTING MODE	17-1
17.1 Items of the Selecting Mode	17-1
17.2 How to Set Selecting Mode	17-3
18 CHECKS AND ADJUSTMENTS	18-1
18.1 Circular Level	18-1
18.2 Adjustment of Vertical Angle 0 Datum	18-2
18.3 Adjustment of Compensation Systematic Error of Instrument	18-3
18.4 Reticle	18-5
18.5 Optical Plummet	18-6
18.6 Additive Distance Constant	18-7
18.7 Checking and Adjusting of Laser Plummet*1	18-8
19 TOP FIELD MODE	19-1
19.1 MAIN MENU (Major Functions)	19-1
19.2 JOB	19-1
19.2.1 To Create New Job	19-1
19.2.2 To Select Existing Job	19-2
19.2.3 To Delete Job	19-2
19.2.4 When Job is not to be Used	19-3
19.3 SETTING	19-3
19.4 GO TO WORK	19-4
19.4.1 To Set Occupied Point and Backsight	19-4
19.4.2 To Layout	19-13
19.4.3 To Conduct Ordinary Measurement and to Record Coordinates	19-14
19.5 DATA MANAGER	19-16
19.5.1 To Add Coordinate Data	19-16
19.5.2 To Delete Coordinate Data	19-20
19.5.3 To View Coordinate Data	19-21
19.5.4 To Edit Coordinate Data	19-22
19.5.5 To Transfer Coordinate Data	19-23
20 SPECIAL ACCESSORIES	20-1
21 BATTERY SYSTEM	21-1
22 PRISM SYSTEM	22-1

23 ERROR DISPLAYS 23-1
24 SPECIFICATIONS 24-1
25 REGULATIONS 25-1
26 OPEN SOURCE SOFTWARE LICENSES 26-1
 26.1 Open Source Software List 26-1
 26.2 Open Source Software Licenses 26-4

1 NOMENCLATURE AND FUNCTIONS

1.1 Nomenclature

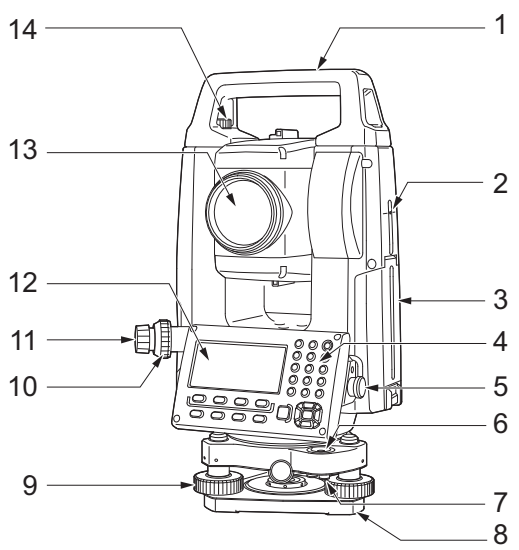

- 1 Handle
- 2 Instrument height mark
- 3 Battery cover
- 4 Operation panel (GM-62 only)
- 5 Serial connector
- 6 Circular level
- 7 Circular level adjusting screws
- 8 Base plate
- 9 Levelling foot screw
- 10 Optical plummet focussing ring
- 11 Optical plummet eyepiece
(10,11: Not included in instruments
with laser plummet)
- 12 Display unit (GM-62 only)
- 13 Objective lens (Includes Laser-pointer
function)
- 14 Handle locking screw
- 15 Tubular compass slot
- 16 Vertical clamp
- 17 Vertical fine motion screw
- 18 External interface hatch (USB port/
Reset button)
- 19 Horizontal fine motion screw
- 20 Horizontal clamp
- 21 Tribrach clamp
- 22 Operation panel
- 23 Display unit
- 24 Telescope eyepiece screw
- 25 Telescope focusing ring
- 26 Sighting collimator
(Gun sight on GM-65 in Face 2 position)
- 27 Instrument center mark

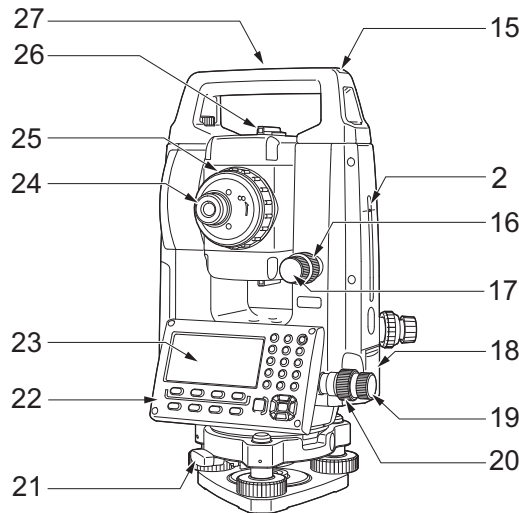

● **Sighting collimator**

Use sighting collimator to aim the GM in the direction of the measurement point. Turn the instrument until the triangle in the sighting collimator is aligned with the target.

A gun sight is mounted on Face 2 position of the GM-65. Align the telescope to the direction of the target in such a way that the gun sight is positioned with the target as shown below. Note that you see the target at a distance from the gun sight.

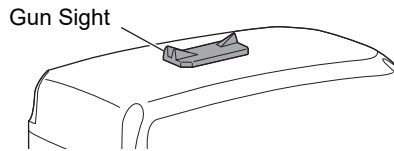

Horizontal direction: a position where you can see both the target and back sight at the center of the front sight's slit.

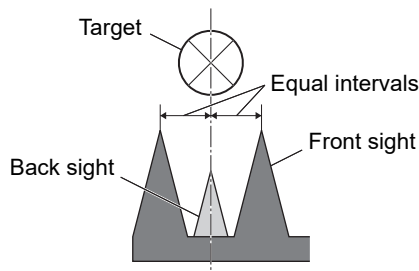

Vertical direction: a position where you can see the tops of the front sight and back sight at the same height of the target's center.

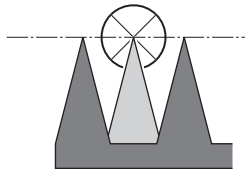

● **Instrument height mark**

The height of the GM is as follows:

- 192.5 mm (from tribrach mounting surface to this mark)
- 236 mm (from tribrach dish (TR-103R) to this mark)

"Instrument height" is input when setting instrument station data and is the height from the measuring point (where GM is mounted) to this mark.

● **Laser-pointer Function**

A target can be sighted with a red laser beam in dark locations without the use of the telescope.

● **Handle**

The carrying handle can be removed from the instrument when the prism is located at the zenith etc.

To remove it, loosen the handle locking screw.

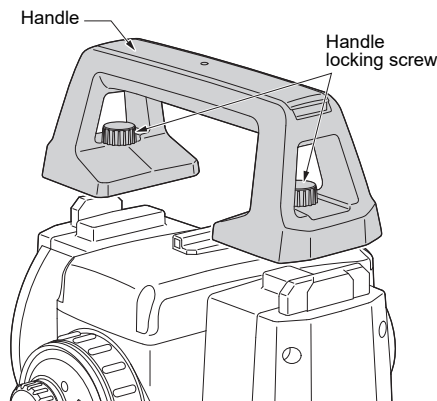

1.2 Display

- **Display**

The display uses a graphic LCD which has 4 lines and 20 characters per line. In general, the upper three lines display measured data, and the bottom line displays the soft key function which changes with the measuring mode.

- **Contrast and Illumination**

The contrast and illumination of display window are adjusted.  See Chapter 6 "SPECIAL MODE (Menu Mode)" or section 1.5 "Starkey mode".

- **Example**

V :	90°10'20"
HR:	120°30'40"
OSET HOLD HSET P1↓	

Angle measurement mode

V-angle : 90°10'20"
H-angle : 120°30'40"

Feet unit

HR:	120°30'40"
HD*	123.45 f
VD:	12.34 f
MEAS MODE NP/P P1↓	

Horizontal-angle : 120°30'40"
Horizontal distance : 123.45 ft
Relative elevation : 12.34 ft

HR:	120°30'40"
HD*	65.432 m
VD:	12.345 m
MEAS MODE NP/P P1↓	

Distance measurement mode





Horizontal-angle : 120°30'40"
Horizontal distance : 65.432 m
Relative elevation : 12.345 m

Feet and inch unit

HR:	120°30'40"
HD*	123.04.6f
VD:	12.03.4f
MEAS MODE NP/P P1↓	

Horizontal-angle : 120°30'40"
Horizontal distance : 123 ft 4 in 6/8 in
Relative elevation : 12 ft 3 in 4/8 in

- **Display marks**

Display	Contents	Display	Contents
V	V-angle	*	EDM working
HR	H-angle right	m	Meter unit
HL	H-angle left	f	Feet unit / Feet and inch unit
HD	Horizontal distance	N P	Non-prism mode
VD	Relative elevation		Sheet mode
SD	Slope distance		Laser emitting mark
N	N coordinate		NP-TRK mode  See Section 6.4.9 "NP-TRK MODE Setting".
E	E coordinate		<i>Bluetooth</i> is under communication. (This symbol mark of the <i>Bluetooth</i> will be displayed above the battery mark when the GM is in the state which can be communicated by <i>Bluetooth</i> .)
Z	Z coordinate		

1.3 Operating Key

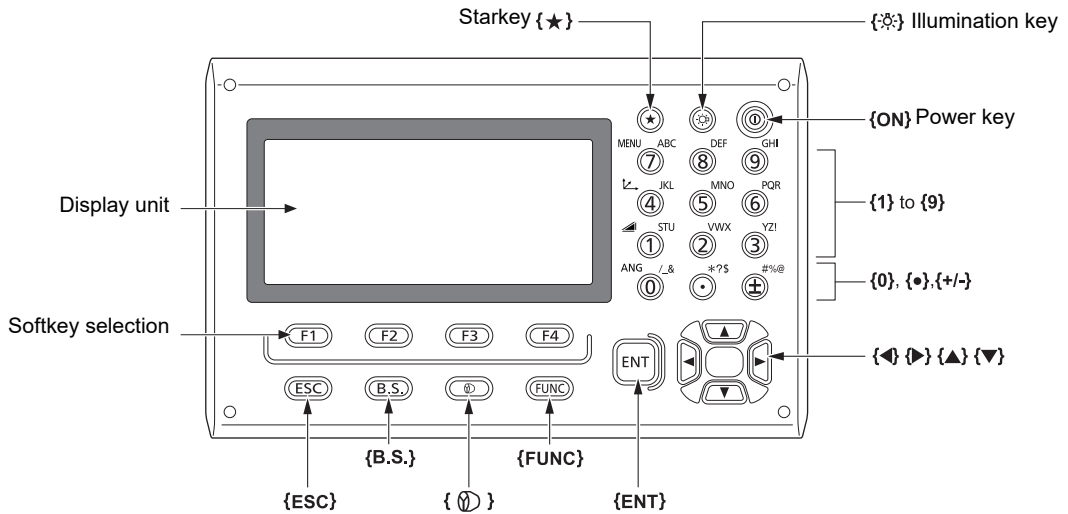

Keys	Name of Key	Function
{★}	Starkey	Switches to Starkey mode This mode is used for each presetting or displaying as follows. 1 Contrast of the display, 2 Reticle illumination, 3 Laser pointer, 4 Tilt correction, 5 Set audio mode, 6 Laser Plummet • Press {★} during Starkey mode to go to the Tilt Screen. ☞ For levelling procedure: see Section 2.5.2 "Levelling".
{↙}	Coordinate meas.key	Switches to coordinate measurement mode
{↗}	Distance meas.key	Switches to distance measurement mode
{ANG}	Angle meas.key	Switches to angle measurement mode
{MENU}	Menu key	Switches to menu mode Starts measurement applications and performs various settings
{☀}	Illumination key	Lights up the display unit and key Switches the screen/key backlight and Reticle illumination ON/OFF
{⊗}	Target key	Switches between target types (prism mode/Sheet mode/Non-prism mode (Reflectorless mode))
{FUNC}	Function key	Switches Starkey mode pages (Laser plummet mounted model only)
{0} – {9} / {.} / {±}	Alphanumeric characters key	Input letters/figures ☞ For entering alphanumeric characters, see Section 2.4 "How to Enter Alphanumeric Characters".
{ESC}	Escape key	<ul style="list-style-type: none"> ● Returns to the measurement mode or previous layer mode from the mode set ● Switches to data collection mode or layout mode directly from the normal measurement mode ● It is also possible to use as Record key in normal measurement mode. ☞ For selecting function of Escape key, see Chapter 17 "SELECTING MODE".
{B.S.}	Backspace key	Delete a character on the left
{ENT}	Enter key	Selects/accepts input word/value

Keys	Name of Key	Function
{⓪}	Power key	Turns ON/OFF of power source (Press and hold: About 1 second)  <ul style="list-style-type: none"> In some cases, it may take longer until Power OFF. Do not remove the battery until the display turns off. Doing so will cause data stored in the GM to be lost.
{F1} – {F4}	Soft key (Function key)	Respond to the message displayed.

1.4 Function Key (Soft Key)

The Soft Key message is displayed at the bottom line of display. The functions are according to the displayed message.

Angle measurement mode

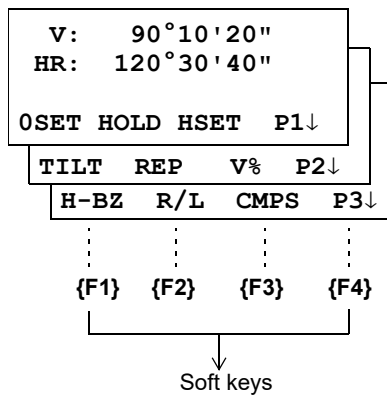

Distance measurement mode

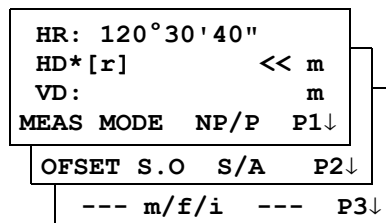

Coordinates measurement mode

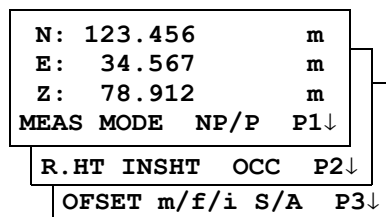

Angle measurement

Page	Soft key	Display mark	Function
1	{F1}	OSET	Angle of Horizontal is set to 0°00'00"
	{F2}	HOLD	Hold the horizontal angle.
	{F3}	HSET	Sets a required horizontal angle by entering numerals.
	{F4}	P1↓	The function of soft keys is shown on next page (P2).
2	{F1}	TILT	Setting Tilt Correction If ON, the display shows tilt correction value.
	{F2}	REP	Repetition angle measurement mode
	{F3}	V%	Vertical angle percent grade(%) mode
	{F4}	P2↓	The function of soft keys is shown on next page (P3).
3	{F1}	H-BZ	Sets the buzzer sound for every horizontal angle 90°.
	{F2}	R/L	Switches R/L rotation of horizontal angle.
	{F3}	CMPS	Switches the COMPASS ON/OFF of vertical angle.
	{F4}	P3↓	The function of soft keys is shown on next page (P1).

Distance measurement mode

1	{F1}	MEAS	Start measuring
	{F2}	MODE	Sets a measuring mode, Fine/Coarse/Tracking.
	{F3}	NP/P	Switches Non-prism mode, prism mode or Sheet mode.
	{F4}	P1↓	The function of soft keys is shown on next page (P2).
2	{F1}	OFSET	Select Off-set measurement mode.
	{F2}	S.O	Select Stake out measurement mode.
	{F3}	S/A	Select Set audio mode.
	{F4}	P2↓	The function of soft keys is shown on next page (P3).
3	{F2}	m/f/i	Switches meter, feet or feet and inch unit.
	{F4}	P3↓	The function of soft keys is shown on next page (P1).

Coordinate measurement mode

1	{F1}	MEAS	Start measuring.
	{F2}	MODE	Sets a measuring mode, Fine/Coarse/Tracking.
	{F3}	NP/P	Switches Non-prism mode, prism mode or Sheet mode.
	{F4}	P1↓	The function of soft keys is shown on next page (P2).
2	{F1}	R.HT	Sets a prism height by input values.
	{F2}	INSHT	Sets an instrument height by input values.
	{F3}	OCC	Sets an instrument coordinate point by input values.
	{F4}	P2↓	The function of soft keys is shown on next page (P3).
3	{F1}	OFSET	Select Off-set measurement mode.
	{F2}	m/f/i	Switches meter, feet or feet and inch unit.
	{F3}	S/A	Select set audio mode.
	{F4}	P3↓	The function of soft keys is shown on next page (P1).

1.5 Starkey mode

Press the {★} key to view the instrument options.

The following instrument options can be selected from the {★}:

1. Adjustment the contrast of the display (0 to 15 steps) {▲} or {▼}
2. Adjustment the reticle illumination (1 to 5 steps) {◀} or {▶}
3. Turn the Laser pointer option ON/OFF
4. Setting Tilt Correction
5. S/A (set audio) mode
6. Adjustment the contrast of the laser plummet (1 to 5 steps) {▲} or {▼}
7. Turn the Laser plummet option ON/OFF



- Starkey mode does not function when the same function as the function assigned to the Starkey mode is performed from the main routine.
- Press {★} during Starkey mode to go to the Tilt Screen.
 For levelling procedure: see Section 2.5.2 "Levelling".

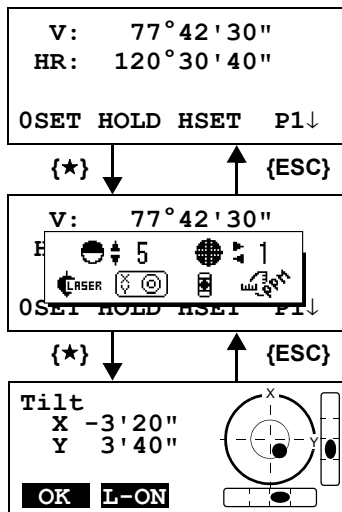

* Screen of laser plummet mounted model

key	Display mark	Function
{F1}		Turn the Laser plummet option ON/OFF
{F2}		Setting Tilt Correction If ON, the display shows tilt correction screen.
{F3}		Turn the Laser pointer option ON / OFF [/]
{F4}		The light acceptance quantity level for the EDM (SIGNAL), the atmospheric correction value (PPM) and correction value of prism constant (PSM / NPM / SHT) are displayed.*1)
{▲} OR {▼}		Adjust the contrast of the display (0 to 15 steps)
{◀} or {▶}		Adjust the Reticle Illumination (1 to 5 steps) ON/OFF of the reticle illumination is linked with ON/OFF of the backlight.
{▲} OR {▼}		Adjust the laser plummet brightness (1 to 5 steps) (displayed only when the laser plummet is ON)

- **Adjustment the contrast (0 to 15) of the display**

This enable you to adjust the contrast of the display.
Press the up or down arrow keys to adjust the contrast.

- **Adjustment the reticle illumination (1 to 5)**

This enable you to adjust the reticle illumination.
Press the right or left arrow keys to adjust the reticle illumination.
The switch of reticle illumination will be interlocked with the switch of display backlight.

- **Lighting and Extinguishing of Laser Pointer**

Whenever the **{F3}** key is pressed, the laser pointer will light up or be extinguished, in that order.
The laser pointer assists with collimation by radiating visible laser light from the objective lens to the target.

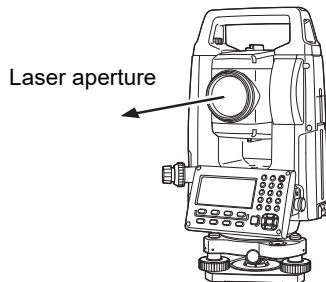

- The laser pointer indicates the approximate collimation position of the telescope. It does not indicate the exact collimation position.
- You cannot see the laser pointer when looking through the telescope. Therefore, please look directly, with the naked eye, at the point indicated by the laser pointer.
- The distance to which the laser pointer can be used will vary with climatic conditions and with the eyesight of the user.
- When the laser pointer is used, the operating time of internal power source will become short.

- **Tilt correction**

The tilt setting mode performed here will not be memorized after powering OFF. To set TILT correction in the initialized setting (it is memorized after powering OFF), see Section 6.4.3 "Vertical and Horizontal Angle Tilt correction (Tilt ON/OFF)".

- **Set audio mode**

The light acceptance quantity level (Signal level) is displayed in this mode.
When reflected light from the prism is received, a buzzer sounds. This function is good for easy collimation when the target is difficult to find.

Press the **{F4}** key to view the set audio screen.

 To stop the buzzer, refer to Chapter 17 "SELECTING MODE".

Also, it is possible to display the signal level in Distance Measuring Mode.

The temperature, pressure, PPM, PSM, NPM and SHT can be viewed in set audio mode.

 Refer to Chapter 11 "SET AUDIO MODE", Chapter 10 "SETTING THE PRISM CONSTANT VALUE" and Chapter 12 "SETTING ATMOSPHERIC CORRECTION", for further instructions.

1.6 Serial signal RS-232C connector

The serial signal connector is used for connecting the GM with a computer or TOPCON Data Collector, which enables the computer to receive measured data from the GM or to send preset data of horizontal angle, etc. to it.

The following data will be output at each mode.

Mode	Output
Angle mode (V, HR or HL) (V in percent)	V, HR (or HL)
Horizontal distance mode (HR, HD, VD)	V, HR, HD, VD
Slope distance mode (V, HR, SD)	V, HR, SD, HD
Coordinate mode	N, E, Z, HR (or V, HR, SD, N, E, Z)

Note

- The display and the output at the coarse mode are the same as the contents above.
- Output at the tracking mode is displayed as distance data only.

 The details necessary for the connection with the GM are obtained from the GM-60 series Interface Manual which is optionally available. Please refer to the manual.

1.7 Bluetooth communication (Only for Bluetooth function built-in models)

By built-in *Bluetooth*, it can communicate with *Bluetooth* instruments by wireless, without connecting a serial signal connector.

2 PREPARATION FOR MEASUREMENT

2.1 Power Switch Key ON

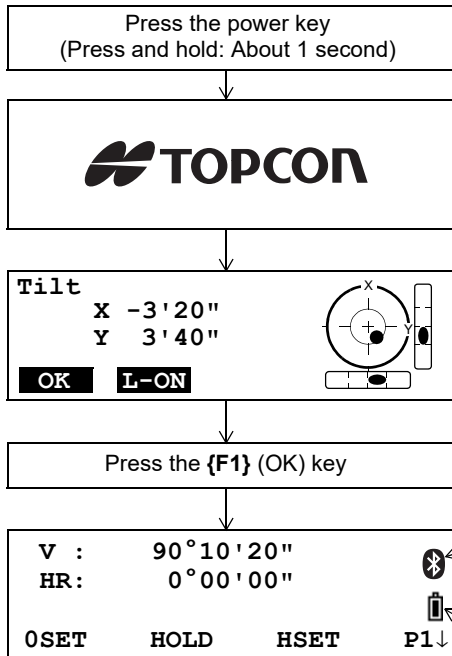

- 1 Confirm the instrument is leveled.
- 2 Press the power key.



Bluetooth is under communication.
(This symbol mark of the Bluetooth will be displayed when the total station is in the state which can be communicated by Bluetooth.)

Battery Power Remaining Display



- Confirm the battery power remaining display. Replace with charged battery or charge when battery level is low or indicates “”.  See Section 2.2 "Battery Power Remaining Display".
- **Contrast adjustment**
You can confirm prism constant value (PSM), non-prism constant value (NPM), sheet constant value (SHT), atmospheric correction value (PPM) and you can also adjust the contrast of the display when the instrument is turned on.
 To display this screen, see Chapter 17 "SELECTING MODE".

CONTRAST ADJUSTMENT			
PSM:	0.0	PPM	0.0
NPM:	0.0	SHT:	0.0
↓	↑	- - -	ENTER

This enables you to adjust the brightness by pressing the {F1} (↓) or {F2} (↑) key.
To memorize the setting value after powering off, press {F4} (ENTER) key.

Note

- If you are experiencing problems with the software, depress the reset button to reboot the program forcibly. Use a provided hexagonal wrench (1.3 mm/1.5 mm) or a tapered rod like a pin to depress down the reset button.



- Avoid using any sharp implement like a needle. Malfunction of the instrument could result.
- Pressing down the Reset button may result in file and folder data being lost.

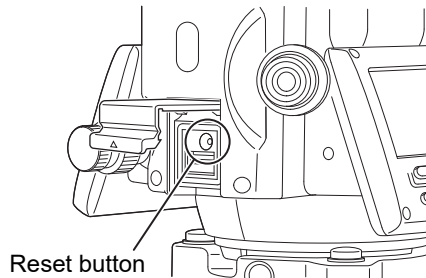

2.2 Battery Power Remaining Display

Battery power remaining display indicates the power condition.

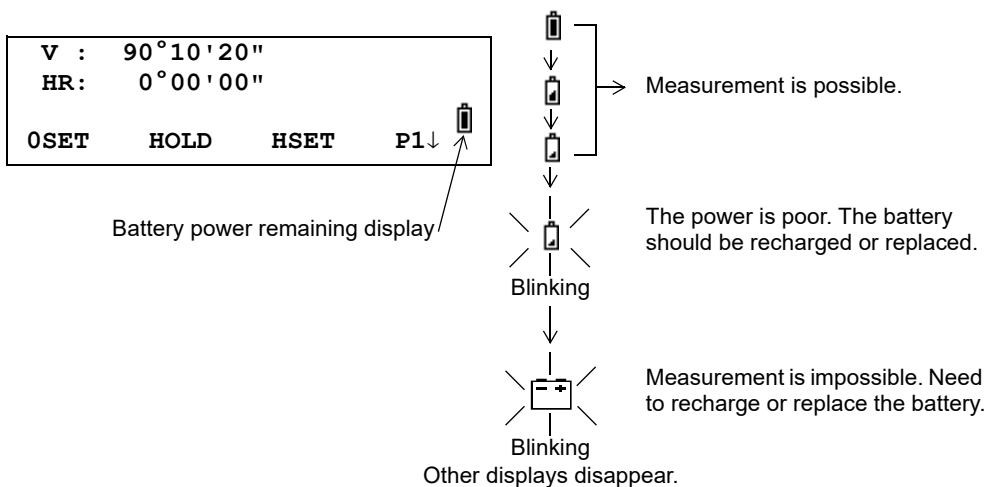

- The battery operating time will vary depending on the environmental conditions such as ambient temperature, charging time, the number of times of charging and discharging etc. It is recommended for safety to charge the battery beforehand or to prepare spare full charged batteries.
- For general usage of the battery, see Chapter 14 "POWER SOURCE AND CHARGING".
- The battery power remaining display shows the power level regarding to the measurement mode now operating.
The safety condition indicated by the battery power remaining display in the angle measurement mode does not necessarily assure the battery's ability to be used in the distance measurement mode.
It may happen that the mode change from the angle mode to the distance mode will stop the operation because of insufficient battery power for the distance mode which consumes more power than angle mode.

2.3 Vertical and Horizontal Angle Tilt Correction

When the tilt sensors are activated, automatic correction of vertical and horizontal angle for mislevelment is displayed.

To ensure a precise angle measurement, tilt sensors must be turned on. The display can also be used to fine level the instrument. If the (TILT OVER) display appears the instrument is out of automatic compensation range and must be leveled manually.

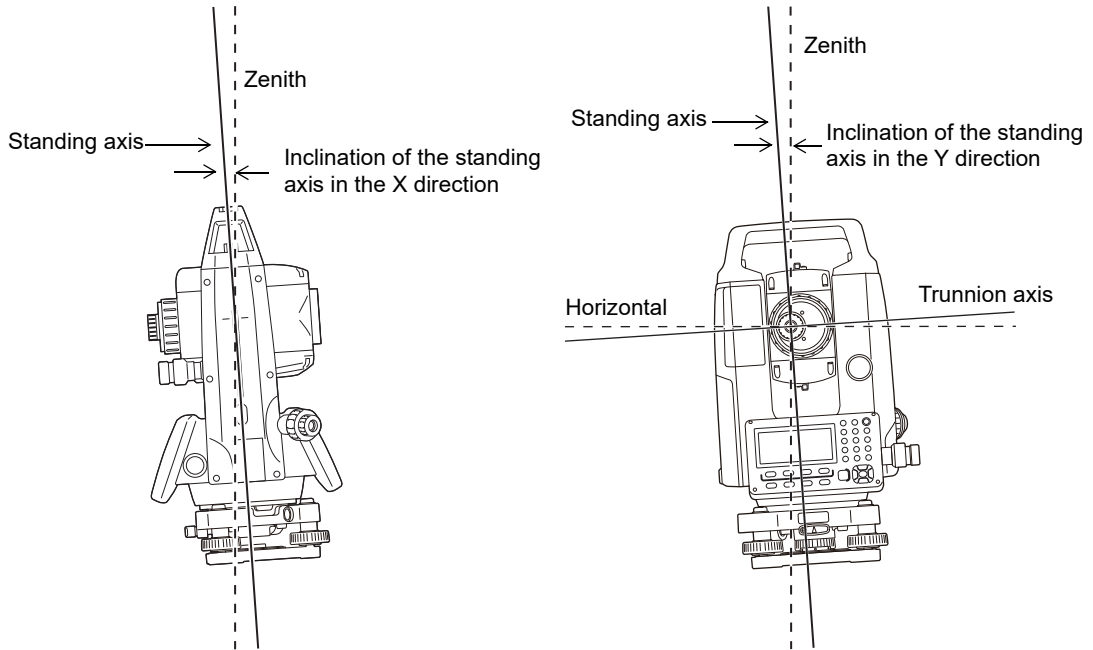

Note

- GM compensates both the vertical angle and the horizontal angle readings due to inclination of the standing axis in the X and Y directions.

When the instrument is out of compensation. (TILT OVER)

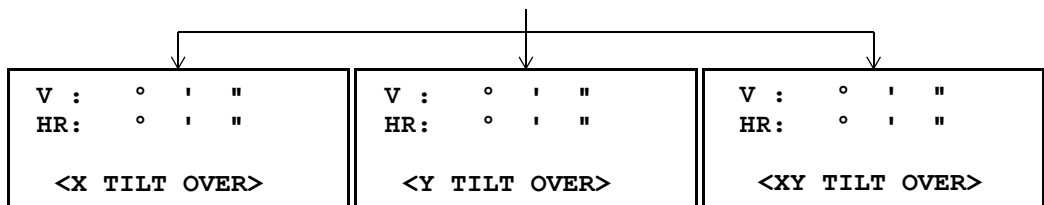

Standing Axis in the X direction
out of range

Standing Axis in the Y direction
out of range

Standing Axis in the X and Y
directions out of range

- The display of Vertical or Horizontal angle is unstable when instrument is on an unstable stage or a windy day. You can turn OFF the auto tilt correction function of V/H angle in this case.
- To set auto tilt correction from the moment that power is on, See Section 6.4.3 "Vertical and Horizontal Angle Tilt correction (Tilt ON/OFF)".

● **Setting Tilt Correction by Soft Key**

To enable you to select tilt ON/OFF function. setting is not memorized after power is OFF.

[Example] Setting X,Y Tilt OFF

Operating procedure	Option	Display
<p>1 Press {F4} key to get the function page 2.</p>	<p>{F4}</p>	<pre>V : 90°10'20" HR: 120°30'40" OSET HOLD HSET P1↓ TILT REP V% P2↓</pre>
<p>2 Press {F1} (TILT) key. In case ON is already selected, the display shows tilt correction value.</p>	<p>{F1}</p>	<pre>TILT SENSOR: [XY-ON] X: -0°00'25" Y: 0°00'20" X-ON XY-ON OFF ---</pre>
<p>3 Press {F3} (OFF) key.</p>	<p>{F3}</p>	<pre>TILT SENSOR: [OFF] X-ON XY-ON OFF ---</pre>
<p>4 Press {ESC} key.</p>	<p>{ESC}</p>	<pre>V : 90°10'20" HR: 120°30'40" OSET HOLD HSET P1↓</pre>
<p>● The setting mode performed here will not be memorized after powering OFF. To set TILT correction in the initialized setting (it is memorized after powering OFF), See Section 6.4.3 "Vertical and Horizontal Angle Tilt correction (Tilt ON/OFF)".</p>		

2.4 How to Enter Alphanumeric Characters

This enables you to enter alphanumeric characters such as the instrument height, prism height, occupied point, backsight point etc.

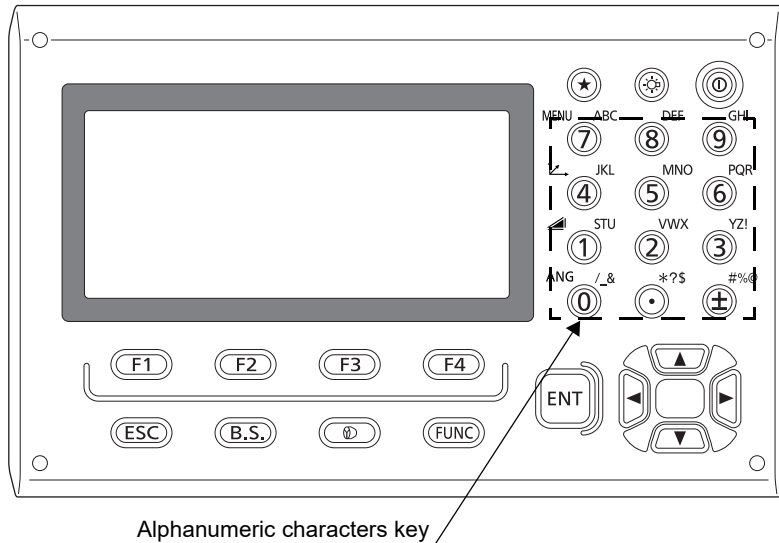

Keys	Name of Key	Function
{0} – {9}	Number key	During numeric input, input number of the key. During alphabetic input, input the characters displayed above the key in the order they are listed.
{.} / {±}	Decimal point key/ Plus-minus sign key	Input a decimal point/plus or minus sign during numeric input. During alphabetic input, input the characters displayed above the key in the order they are listed.
{◀} / {▶}	Cursor key	Right and left cursor/Select other option.
{▲} / {▼}	Cursor key	Up and down cursor.
{ESC}	Escape key	Cancel the input data.
{B.S.}	Backspace key	Delete a character on the left.
{ENT}	Enter key	Select/accept input word/value.

● **How to select a item**

[Example setting] Occupied point in the data collection mode.

The arrow indicates a item to enter.

The arrow line moves up or down when the {▼} key or {▲} key is pressed.

{▼}
or
{▲}

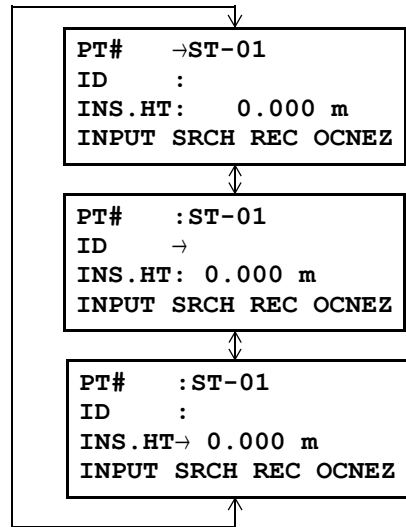

● **How to enter characters**

[Example setting] TOPCON-1

1 Move the arrow to enter a item using the {▼} or {▲} key.

```
PT#   →
ID    :
INS.HT: 0.000 m
INPUT SRCH REC OCNEZ
```

2 Press the {F1} (INPUT) key.
The arrow changes to the equal (=).
The instrument switches to numerical input mode.

```
PT#   =
ID    :
INS.HT: 0.000 m
[ALP] [SPC] [CLR] [ENT]
```

3 Press the {F1} ([ALP]) key.
The instrument switches to alphabetical input mode.

```
PT#   =
ID    :
INS.HT: 0.000 m
[NUM] [SPC] [CLR] [ENT]
```

4 Enter letters of the alphabet by pressing the alphanumeric characters key.
Example: {1} (STU) key is pressed twice.

```
PT#   =T
ID    :
INS.HT: 0.000 m
[NUM] [SPC] [CLR] [ENT]
```

5 Enter other letters of the alphabet in the same way.

```
PT#   =TOPCON
ID    :
INS.HT: 0.000 m
[NUM] [SPC] [CLR] [ENT]
```

- 6** Press the **{F1}** (NUM) key, again.
The instrument switches back to numerical input mode.

```
PT#    =TOPCON
ID     :
INS.HT: 0.000 m
[ALP] [SPC] [CLR] [ENT]
```

- 7** Enter numbers by pressing the alphanumeric characters key.

Example: **{ - }**, **{ 1 }** key is pressed.

```
PT#    =TOPCON-1
ID     :
INS.HT: 0.000 m
[ALP] [SPC] [CLR] [ENT]
```

- 8** Press **{F4}** (ENT) key.
The arrow moves to next item.

Select next character in the same manner.

Note

- To correct a character, move the cursor to correct character by pressing **{◀}** or **{▶}** key and enter again.

2.5 Setting Instrument Up for Measurement

Mount the instrument to the tripod. Level and center the instrument precisely to insure the best performance. Use tripods with a tripod screw of 5/8 in. diameter and 11 threads per inch, such as the Type E TOPCON wide-frame wooden tripod.



- Mount the battery in the instrument before performing this operation because the instrument will tilt slightly if the battery is mounted after levelling.

2.5.1 Centering

● PROCEDURE: Centering with the optical plummet eyepiece

- 1 Make sure the legs are spaced at equal intervals and the head is approximately level.
Set the tripod so that the head is positioned over the survey point.
Make sure the tripod shoes are firmly fixed in the ground.

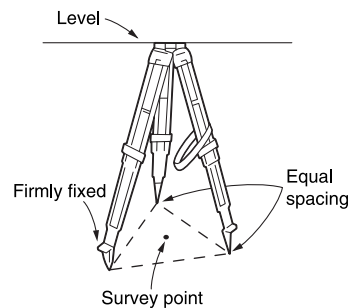

- 2 Place the instrument on the tripod head.
Supporting it with one hand, tighten the centering screw on the bottom of the unit to make sure it is secured to the tripod.

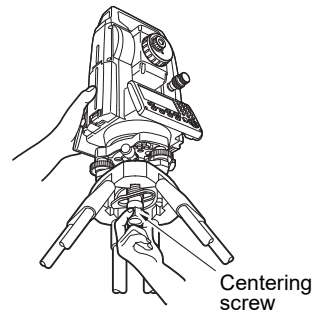

- 3 Looking through the optical plummet eyepiece, turn the optical plummet eyepiece to focus on the reticle.
Turn the optical plummet focussing ring to focus on the survey point.

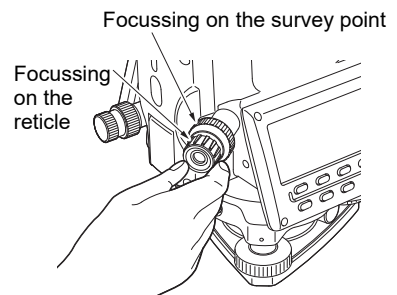

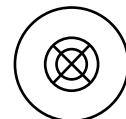

- 4 Adjust the levelling foot screws to center the survey point in the optical plummet reticle.



- 5 Continue to the levelling procedure.
☞ See Section 2.5.2 "Levelling".

● **PROCEDURE: Centering with the laser plummet***1

*1: Laser plummet is available as a factory option depending on the country or the area where the instrument is purchased.

- 1) Set up the tripod and affix the instrument on the tripod head.
 "PROCEDURE: Centering with the optical plummet eyepiece" steps 1 and 2
- 2) Power ON the instrument.
 See Section 2.1 "Power Switch Key ON".
 The electric circular level is displayed on the Tilt screen.

- 3) Press **[L-ON]**.
 The laser plummet beam will be emitted from the bottom of the instrument.

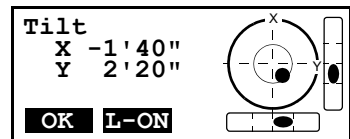

- Use **{◀/▶}** in the second page to adjust the brightness of the laser.

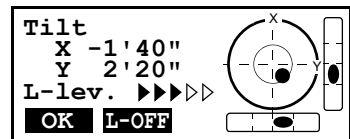

- 4) Using levelling foot screws, adjust the position of the instrument on the tripod until the laser beam is aligned with the center of the survey point.
- 5) Press **[L-OFF]** to turn the laser plummet off.
 Alternatively, press **{ESC}** to return to the previous screen. The laser plummet will switch off automatically.

 **Note**

- Visibility of the laser spot may be affected when operating in direct sunlight. In this event, provide shade for the survey point.
- Laser plummet can be operated in Starkey mode as well.
 See Section 1.5 "Starkey mode".

2.5.2 Levelling

● **PROCEDURE**

- 1) Perform the centering procedure.
 ☞ See Section 2.5.1 "Centering".
- 2) Roughly center the bubble in the circular level by either shortening the tripod leg closest to the offcenter direction of the bubble or by lengthening the tripod leg farthest from the offcenter direction of the bubble. Adjust one more tripod leg to center the bubble.

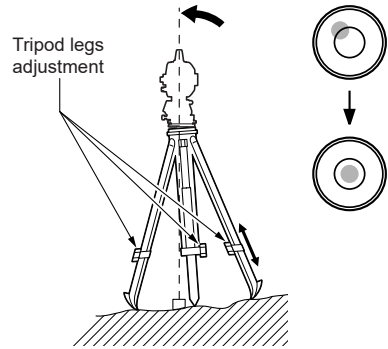

- 3) Power ON the instrument.
 ☞ See Section 2.1 "Power Switch Key ON".
 The electric circular level is displayed on the <Tilt>.
 "●" indicates the bubble in circular level. The range of the inside circle is $\pm 4'$ and the range of the outside circle is $\pm 6'$.
 Tilt angle values X and Y are also displayed on the screen.

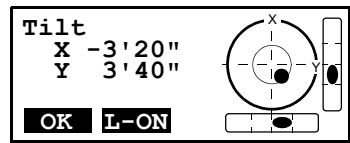

- "●" is not displayed when the tilt of the instrument exceeds the detection range of the tilt sensor. Level the instrument while checking the air bubbles in the circular level until "●" is displayed on the screen.



Note

- When executing the measurement program, if measurement starts with the instrument tilted, the circular level is displayed on the screen.
- 4) Using levelling foot screws, center "●" in the circular level.
 First, turn the instrument until the telescope is parallel to a line between levelling foot screws A and B. Next, set the tilt angle to 0° using foot screws A and B for the X direction and levelling screw C for the Y direction.

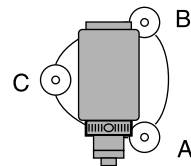

- When the bubble is in the center, proceed to step 5.
- 5) Loosen the centering screw slightly.
 Looking through the optical plummet eyepiece, slide the instrument over the tripod head until the survey point is exactly centered in the reticle.
 Retighten the centering screw securely.

If the instrument is levelled using laser plummet, emit the laser plummet beam and check it again.
 ☞ See "PROCEDURE: Centering with the laser plummet*1"

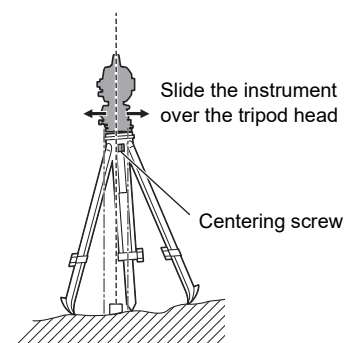

- 6) Check again to make sure the bubble in the electric circular level is centered.
If not, repeat the procedure starting from step 4.
- 7) Press **{OK}** to return to Observation mode.

2.6 FOCUSING AND TARGET SIGHTING



- When sighting the target, strong light shining directly into the objective lens may cause the instrument to malfunction. Protect the objective lens from direct light by attaching the lens hood. Observe to the same point of the reticle when the telescope face is changed.

● PROCEDURE

- 1 Look through the telescope eyepiece at a bright and featureless background.
Turn the eyepiece screw clockwise, then counterclockwise little by little until just before the reticle image becomes focussed.
Using these procedures, frequent reticle refocussing is not necessary since your eye is focussed at infinity.
- 2 Loosen the vertical and horizontal clamps, then use the sighting collimator to bring the target into the field of view. Tighten both clamps.
- 3 Turn the telescope focussing ring to focus on the target.
Turn the vertical and horizontal fine motion screws to align the target with the reticle.
The last adjustment of each fine motion screw should be in the clockwise direction.
- 4 Readjust the focus with the focussing ring until there is no parallax between the target image and the reticle.

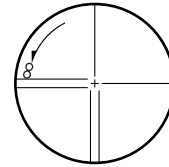

● Eliminating parallax

This is the relative displacement of the target image with respect to the reticle when the observer's head is moved slightly before the eyepiece. Parallax will introduce reading errors and must be removed before observations are taken. Parallax can be removed by refocussing the reticle.

3 ANGLE MEASUREMENT

3.1 Measuring Horizontal Angle Right and Vertical Angle

Make sure the mode is in Angle measurement.

Operating procedure	Operation	Display
1 Collimate the 1st target (A).	Collimate A	<div style="border: 1px solid black; padding: 2px;"> V : 90°10'20" HR: 120°30'40" 0SET HOLD HSET P1↓ </div>
2 Set horizontal angle of target A at 0° 00' 00". Press the {F1} (0 set) key and press the {F3} (YES) key.	{F1}	<div style="border: 1px solid black; padding: 2px;"> H ANGLE 0 SET > OK? --- --- [YES] [NO] </div>
	{F3}	<div style="border: 1px solid black; padding: 2px;"> V : 90°10'20" HR: 0°00'00" 0SET HOLD HSET P1↓ </div>
3 Collimate the 2nd target (B). The required V/H angle to target B will be displayed.	Collimate B	<div style="border: 1px solid black; padding: 2px;"> V : 98°36'20" HR: 160°40'20" 0SET HOLD HSET P1↓ </div>

3.2 Switching Horizontal Angle Right/Left

Make sure the mode is Angle measurement.

Operating procedure	Operation	Display
1 Press the {F4} (↓) key twice to get the function on page 3.	{F4} twice	<div style="border: 1px solid black; padding: 2px;"> V : 90°10'20" HR: 120°30'40" 0SET HOLD HSET P1↓ </div>
		<div style="border: 1px solid black; padding: 2px;"> TILT REP V% P2↓ H-BZ R/L CMPS P3↓ </div>
		<div style="border: 1px solid black; padding: 2px;"> V : 90°10'20" HL: 239°29'20" H-BZ R/L CMPS P3↓ </div>
2 Press the {F2} (R/L) key. The mode Horizontal angle Right (HR) switches to (HL) mode.	{F2}	
3 Measure as HL mode.		
<ul style="list-style-type: none"> Every time pressing the {F2} (R/L) key, HR/HL mode switches. 		

3.3 Measuring from the Required Horizontal Angle

3.3.1 Setting by Holding the Angle

Make sure the mode is angle measurement.

Operating procedure	Operation	Display
1 Set the required horizontal angle, using Horizontal tangent screw	Display angle	V : 90°10'20" HR: 130°40'20" 0SET HOLD HSET P1↓
2 Press the {F2} (HOLD) key.	{F2}	H ANGLE HOLD HR: 130°40'20" >SET ? --- --- [YES] [NO]
3 Collimate the target.	Collimate	
4 Press the {F3} (YES) key to finish holding the horizontal angle.*1) The display turns back to normal angle measurement mode.	{F3}	V : 90°10'20" HR: 130°40'20" 0SET HOLD HSET P1↓
*1) To return to the previous mode, press the {F4} (NO) key.		

3.3.2 Setting a Horizontal Angle from the Keys

Make sure the mode is Angle measurement.

Operating procedure	Operation	Display
1 Collimate the target.	Collimate	V : 90°10'20" HR: 170°30'20" 0SET HOLD HSET P1↓
2 Press the {F3} (HSET) key.	{F3}	H ANGLE SET HR= --- --- [CLR] [ENT]
3 Input the required horizontal angle by using keys. *1) For example:70°40'20" When completed, normal measuring from the required Horizontal angle is possible.	70.4020 {F4}	V : 90°10'20" HR: 70°40'20" 0SET HOLD HSET P1↓
*1) To enter Alphanumeric characters, see Section 2.4 "How to Enter Alphanumeric Characters".		

3.4 Vertical Angle Percent Grade(%) Mode

Make sure the mode is Angle measurement.

Operating procedure	Operation	Display
1 Press the {F4} (↓) key to get the function on page 2.	{F4}	V : 90°10'20" HR: 70°40'20" OSET HOLD HSET P1↓ TILT REP V% P2↓
2 Press the {F3} (V%) key. *1)	{F3}	V : -0.30 % HR: 170°30'20" TILT REP V% P2↓

*1) Every time pressing the **{F3}** (V%) key, the display mode switches.

- When the measurement is carried out over $\pm 45^\circ$ ($\pm 100\%$) from the horizontal, the display shows <OVER>.

3.5 Repetition Angle Measurement

Repetition angle measurement can be done by horizontal angle right measurement mode.
Make sure the mode is Horizontal Angle Right measurement.

Operating procedure	Operation	Display
1 Press the {F4} (↓) key to get the function on page 2.	{F4}	V : 90°10'20" HR: 170°30'20" OSET HOLD HSET P1↓ TILT REP V% P2↓
2 Press the {F2} (REP)key.	{F2}	REPETITION ANGLE >OK? --- --- [YES] [NO]
3 Press the {F3} (YES) key.	{F3}	REP-ANGLE COUNT[0] Ht: 0°00'00" Hm: OSET V/H REL HOLD
4 Collimate the target A and press the {F1} (OSET) key.	Collimate A {F1}	REPETITION ANGLE INITIALIZE >OK? --- --- [YES] [NO]
5 Press the {F3} (YES) key.	{F3}	REP-ANGLE COUNT[0] Ht: 0°00'00" Hm: OSET V/H REL HOLD
6 Collimate the target B using the horizontal clamp and tangent screw. Press the {F4} (HOLD) key.	Collimate B {F4}	REP-ANGLE COUNT[1] Ht: 45°10'00" Hm: 45°10'00" OSET V/H REL HOLD

<p>7 Recollimate target A using the horizontal clamp and tangent screw, and press the {F3} (REL)key.</p>	<p>Collimate A {F3}</p>	<pre>REP-ANGLE COUNT[1] Ht: 45°10'00" Hm: 45°10'00" OSET V/H REL HOLD</pre>
<p>8 Recollimate target B using the horizontal clamp and tangent screw, and press the {F4} (HOLD) key.</p>	<p>Collimate B {F4}</p>	<pre>REP-ANGLE COUNT[2] Ht: 90°20'00" Hm: 45°10'00" OSET V/H REL HOLD</pre>
<p>9 Repeat 7 to 8 to measure the desired number of repetitions.</p>		<pre>REP-ANGLE COUNT[4] Ht: 180°40'00" Hm: 45°10'00" OSET V/H REL HOLD</pre>
<p>10 To return to the normal angle mode, press the {F2} (V/H) key or {ESC} key.</p>	<p>{ESC} or {F2}</p>	<pre>REPETITION ANGLE Exit >OK? --- --- [YES] [NO]</pre>
<p>11 Press the {F3} (YES) key.</p>	<p>{F3}</p>	<pre>V : 90°10'20" HR: 170°30'20" OSET HOLD HSET P1↓</pre>
<ul style="list-style-type: none"> ● Horizontal angle can be accumulated up to (3600°00'00" – minimum reading) (horizontal angle right). In case of 5 second reading, horizontal angle can be accumulated up to +3599°59'55". ● Error will be displayed when the results differ from first measurement by more than ±30". 		

3.6 Buzzer Sounding for Horizontal Angle 90° Increments

When the horizontal angle falls in the range of less than ± 1° of 0°, 90°, 180° or 270°, the buzzer sounds. Buzzer stops only when the horizontal angle is adjusted to 0°00'00", 90°00'00", 180°00'00" or 270°00'00".

This setting is not memorized after powering off. Refer to 17 "SELECTING MODE" to set the initial setting (memorized after powering off).

Make sure the mode is Angle measurement.

Operating procedure	Operation	Display
<p>1 Press the {F4} (↓) key twice to get the function on page 3.</p>	<p>{F4} twice</p>	<pre>V : 90°10'20" HR: 170°30'20" OSET HOLD HSET P1↓ H-BZ R/L CMPS P3↓</pre>
<p>2 Press the {F1} (H-BZ) key. The data previously set is shown.</p>	<p>{F1}</p>	<pre>H-ANGLE BUZZER [OFF] [ON] [OFF] --- ENTER</pre>

<p>3 Press the {F1} (ON) key or {F2} (OFF) key to select the buzzer ON/OFF.</p>	<p>{F1} or {F2}</p>	<p>H-ANGLE BUZZER [ON]</p> <p>[ON] [OFF] --- ENTER</p>
<p>4 Press the {F4} (ENTER) key.</p>	<p>{F4}</p>	<p>V : 90°10'20" HR: 170°30'20"</p> <p>0SET HOLD HSET P1↓</p>

3.7 Compasses (vertical angle)

Vertical angle is displayed as shown below.

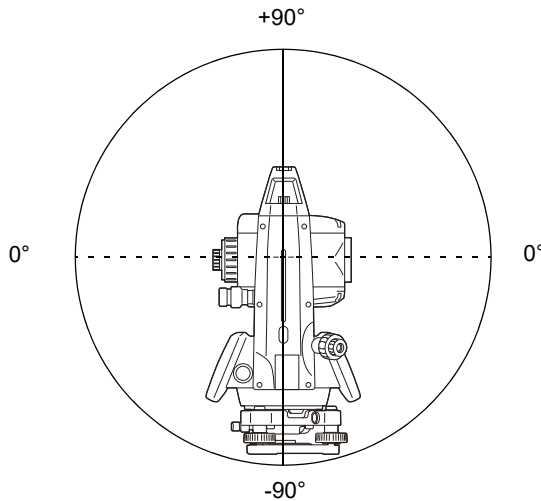

Operating procedure	Operation	Display
<p>1 Press the {F4} (↓) key twice to get the function on page 3.</p>	<p>{F4} twice</p>	<p>V : 98°10'20" HR: 170°30'20"</p> <p>0SET HOLD HSET P1↓</p> <p>H-BZ R/L CMPS P3↓</p>
<p>2 Press the {F3} (CMPS) key. *1)</p>	<p>{F3}</p>	<p>V : - 8°10'20" HR: 170°30'20"</p> <p>H-BZ R/L CMPS P3↓</p>

*1) Every time pressing the **{F3}** (CMPS) key, the display mode switches.

4 DISTANCE MEASUREMENT

⚠ CAUTION

- When using the Laser-pointer function, be sure to turn OFF the output laser after distance measurement is completed. Even if distance measurement is canceled, the Laser-pointer function is still operating and the laser beam continues to be emitted.



- Make sure that the target setting on the instrument matches the type of target used. GM automatically adjusts the intensity of the laser beam and switches the distance measurement display range to match the type of target used. If the target does not correspond to the target settings, accurate measurement results cannot be obtained.
- Accurate measurement results cannot be obtained if the objective lens is dirty. Dust it off with the lens brush first, to remove minute particles. Then, after providing a little condensation by breathing on the lens, wipe it off with the silicon cloth.
- During reflectorless measurement, if an object obstructs the light beam used for measurement or an object is positioned with a high reflective factor (metal or white surface) behind the target, accurate measurement results may not be received.
- Scintillation may affect the accuracy of distance measurement results. Should this occur, repeat measurement several times and use the averaged value of the obtained results.

● Target type (Prism mode / Non-prism Mode (Reflectorless mode) / Sheet mode)

Measurement mode can be selected depending on the object to measure; Prism mode, Non-prism mode (objects other than prism), and Sheet mode.

- Regardless of whether the laser pointer is used, measurement is possible with both the Non-prism mode, Sheet mode and the Prism mode. That is, when the GM is used in the open air, in an urban area, etc., the laser pointer can be stopped and distance measurement then conducted, making it possible to prevent the laser light from hitting a third party.
- For measurement with a prism, be sure to measure with the Prism mode. If you measure with the Non-prism mode and Sheet mode accuracy cannot be guaranteed.
- Non-prism mode enable all distance measurements such Distance measurement, Coordinate measurement, Offset measurement and Layout.
- To switch over Prism mode to Non-prism mode or Sheet mode, press the **[NP/P]** soft key in each measurement display.

When selecting Non-prism mode or Sheet mode, the icon on the right side of the screen indicates the currently selected mode.

[] : Non-prism mode

[] : Sheet mode

Changing mode shall be done before measurement.

Example Distance measurement mode

```

HR: 120°30'40"
HD* 65.432 mNP
VD: 12.345 m
MEAS MODE NP/P P1↓
  
```

Non-prism
mode
indicator

Coordinate measurement mode

```

N: 120.456 m
E: 34.567 mNP
Z: 12.345 m
MEAS MODE NP/P P1↓
  
```

To change the mode, press the **[NP/P]** soft key in each measurement.

- It is possible to set Non-prism mode for distance measurement during the power on time. Refer to 17 "SELECTING MODE" to set the option.
- When collimating a near distance prism in Non-prism mode, measurement may not be performed because of too much light.

4.1 Setting of the Atmospheric Correction

When setting the atmospheric correction, obtain the correction value by measuring the temperature and pressure.  Refer to Section 12.2 "Setting of Atmospheric Correction Value".

4.2 Setting of the Correction for Prism Constant







Topcon's prism constant value is 0. Set correction for prism at 0. If the prism is of another manufacture, the appropriate constant shall be set beforehand.  Refer to Chapter 10 "SETTING THE PRISM CONSTANT VALUE". The setting value is kept in the memory even after power is off.



- Prism constant correction value should be set for each measuring mode. Confirm that Non-prism correction value is set at zero before measurement target such as a wall in Non-prism mode or Sheet mode.

4.3 Distance Measurement (Continuous Measurement)

Make sure the mode displays angle measurement.





Operating procedure	Operation	Display
1 Collimate the center of prism.	Collimate P	V : 90°10'20" HR: 120°30'40" OSET HOLD HSET P1↓
2 Press the  key. Distance measurement starts. *1),2)		HR: 120°30'40" HD* [r] << m VD: m MEAS MODE NP/P P1↓
The measured distances are shown. *3)~*5)		↓
		HR: 120°30'40" HD* 123.456 m VD: 5.678 m MEAS MODE NP/P P1↓
<ul style="list-style-type: none"> Pressing the  key again, the display changes to horizontal (HR) and vertical (V) angle and slope distance(SD). *6) 		V : 90°10'20" HR: 120°30'40" SD* 131.678 m MEAS MODE NP/P P1↓
<p>*1) When EDM is working, the "*" mark appears in the display.</p> <p>*2)  To change mode from Fine to Coarse or Tracking, refer to section 4.5 "Fine Mode/Tracking Mode/Coarse Mode".  To set the distance measurement on when the instrument is powered on, refer to Chapter 17 "SELECTING MODE".</p> <p>*3) The distance unit indicator "m" (for meter), "f" (for feet or feet inch) appears and disappears alternatively with buzzer sounds at every renewal of distance data.</p> <p>*4) Measurement may repeat automatically in the instrument if the result is affected by shimmer etc.</p> <p>*5) To return to the normal measuring angle mode from a distance measuring mode, press the {ANG} key.</p> <p>*6) It is possible to choose the display order (HR, HD, VD) or (V, HR, SD) for initial distance measuring mode.  Refer to Chapter 17 "SELECTING MODE".</p>		

4.4 Distance Measurement (N-time Measurement/Single Measurement)

When the number of times measurement is preset, the GM measures the distance the set number of times. The average distance will be displayed.

When presetting the number of times as 1, it does not display the average distance, because of single measurement. Single measurement is set at the factory.

Make sure the mode displays angle measurement.

Operating procedure	Operation	Display
1 Collimate the center of prism.		V : 90°10'20" HR: 120°30'40" OSET HOLD HSET P1↓
2 Press the  key. Continuous measuring starts.*1)		HR: 120°30'40" HD*[r] << m VD: m MEAS MODE NP/P P1↓
3 Press {F1} (MEAS) key while continuous measuring is exceeding. *2) The average value is displayed and "" mark disappears.	{F1}	HR: 120°30'40" HD*[n] << m VD: m MEAS MODE NP/P P1↓
<ul style="list-style-type: none"> While EDM is working, press {F1} (MEAS) key again, the mode will be changed to continuous measuring mode. 		↓ HR: 120°30'40" HD: 123.456 m VD: 5.678 m MEAS MODE NP/P P1↓
*1) It is possible to set the measurement mode for N-times measurement mode or continuous measurement mode when the power is turned on.  Refer to Chapter 17 "SELECTING MODE". *2)  For setting the number of times (N-times) in the measurement, refer to Chapter 17 "SELECTING MODE".		

- **Choose meter /feet / feet+inch unit by soft key**

It is possible to change the unit for distance measurement mode by soft key.

This setting is not memorized after power off.  Refer to 17 "SELECTING MODE" to set at the initial setting (memorized after power off).

Operating procedure	Operation	Display
1 Press the {F4} (P1↓) key twice to get the function on page 3.	{F4}	HR: 120°30'40" HD* 2.000 m VD: 3.000 m MEAS MODE NP/P P1↓ OFSET S.O S/A P2↓ --- m/f/i --- P3↓
2 Press the {F2} (m/f/i) key, the display unit will be changed. <ul style="list-style-type: none"> Every time pressing the {F2} (m/f/i) key, the unit mode switches. 	{F2}	HR: 120°30'40" HD* 6.560 f VD: 9.845 f --- m/f/i --- P3↓

4.6 Stake Out (S.O)

The difference between the measured distance and the input stake out distance is displayed.

Measured distance — Stake out distance = Displayed value

In stake out operation, you can select either horizontal distance (HD), relative elevation (VD) and slope distance (SD)

Operating procedure	Operation	Display
1 Press the {F4} (↓) key in the distance measuring mode to get the function on page 2.	{F4}	<pre> HR: 120°30'40" HD* 123.456 m VD: 5.678 m MEAS MODE NP/P P1↓ OFSET S.O S/A P2↓ </pre>
2 Press the {F2} (S.O) key. The data previously set is shown.	{F2}	<pre> STAKE OUT HD : 0.000 m HD VD SD --- </pre>
3 Select the measuring mode by pressing the {F1} to {F3} key. Example: Horizontal distance	{F1}	<pre> STAKE OUT HD = 0.000 m --- --- [CLR] [ENT] </pre>
4 Enter the distance for stake out. *1)	Enter data {F4}	<pre> STAKE OUT HD : 100.000 m INPUT --- --- ENTER </pre>
5 Collimate the target (Prism). Measuring starts. The difference between the measured distance and the stake out distance is displayed.	Collimate P	<pre> HR: 120°30'40" dHD*[r] << m VD: m MEAS MODE NP/P P1↓ </pre> <p style="text-align: center;">↓</p> <pre> HR: 120°30'40" dHD* 23.456 m VD: 5.678 m MEAS MODE NP/P P1↓ </pre>
6 Move the target until the difference becomes 0 m.		
<p>*1)  Refer to section 2.4 "How to Enter Alphanumeric Characters".</p> <ul style="list-style-type: none"> ● To return to normal distance measurement mode, stake out distance to "0" or turn the power off. 		

4.7 Offset Measurement

There are four offset measurement modes in the Offset Measurement.

- Angle offset
- Distance offset
- Plane offset
- Column offset

To show the offset measurement menu, press the **[OFFSET]** soft key from distance or coordinate measurement mode.

Example:

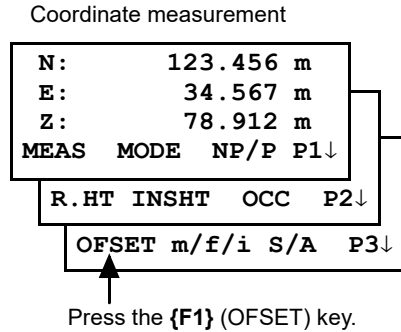
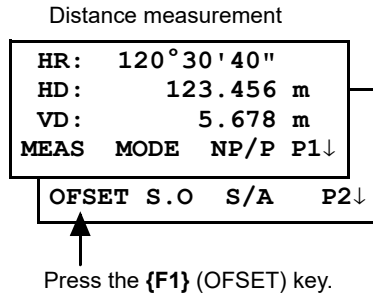

Offset Measurement Menu

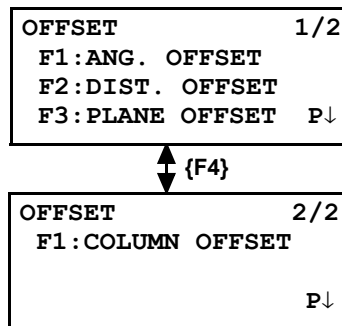

● Outputting the Measurement Data

The results of offset measurement can be output to external device.

Setting the function of the **{ESC}** key to (REC), the **{F3}** soft key which assigned (REC) will appear in measured result display.

☞ Refer to Chapter 17 "SELECTING MODE" to set this option.

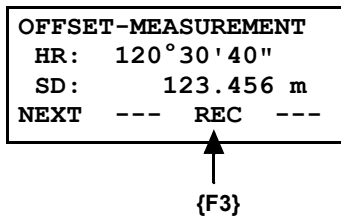

● Distance measurement mode of the offset measurement

Offset measurement will be done by N-time fine measurement mode.

☞ For setting measuring times refer to Chapter 17 "SELECTING MODE".

4.7.1 Angle Offset

This mode is useful when it is difficult to set up the prism directly, for example at the center of a tree. Place the prism at the same horizontal distance from the instrument as that of point A_0 to measure. To measure the coordinates of the center position, operate the offset measurement after setting the instrument height/prism height.

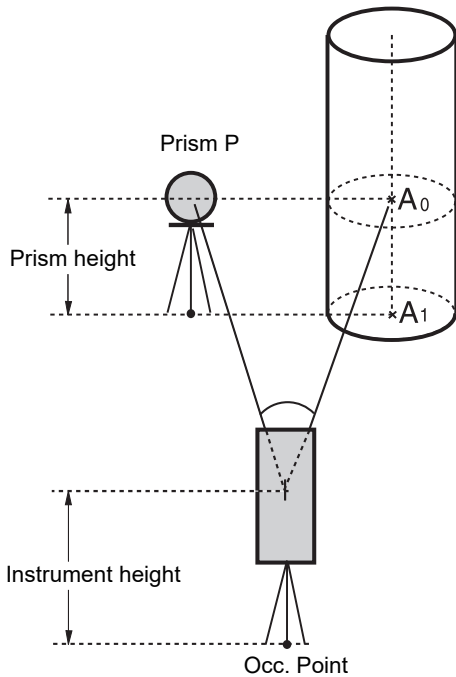

When measuring coordinates of ground point A_1 : Set the instrument height/prism height.

When measuring coordinates of point A_0 : Set the instrument height only. (Set the prism height to 0).

You can choose the vertical angle setting when sighting A_0 from "Hold" or "Free". "Hold" is the setting to fix the vertical angle regardless of telescope direction. When "Free" is selected, the vertical angle value varies in conjunction with the telescope direction and SD (Slope Distance) and VD (Vertical Distance) are updated on a real-time basis.





☞ To set this option, refer to Chapter 17 "SELECTING MODE".

Note

- Set the instrument height/prism height before proceeding to the offset measurement mode.
- When setting the coordinate value for the occupied station, refer to Section 5.1 "Setting Coordinate Values of Occupied Point".

Operating procedure	Operation	Display
1 Press the {F4} (P1↓) key from distance measuring mode to get the function on page 2.	{F4}	<pre> HR: 120°30'40" HD: 123.456 m VD: 5.678 m MEAS MODE NP/P P1↓ OFFSET S.O S/A P2↓ </pre>
2 Press the {F1} (OFFSET) key.	{F1}	<pre> OFFSET 1/2 F1:ANG.OFFSET F2:DIST.OFFSET F3:PLANE OFFSET P1↓ </pre>
3 Press the {F1} (ANG. OFFSET) key.	{F1}	<pre> OFFSET-MEASUREMENT HR: 120°30'40" HD: m MEAS --- NP/P --- </pre>
4 Collimate prism P, and press the {F1} (MEAS) key.	Collimate P {F1}	<pre> OFFSET-MEASUREMENT HR: 110°20'30" HD* [n] << m >Measuring... </pre> <p style="text-align: center;">↓</p>

The horizontal distance from the instrument to the prism will be measured.

- 5 Collimate point A_0 using the horizontal motion clamp and horizontal tangent screw.
- 6 Press the  key, to switch the distance display to VD (relative elevation of point A_0).
- 7 Press the  key, to switch the distance display to SD (slope distance).
 - Each time pressing the  key, horizontal distance, relative elevation and slope distance are shown in sequence.
- 8 Press the  key, to switch the distance display to N (N coordinate of point A_0 or A_1).
 - Each time pressing  key, N,E and Z coordinate are shown in sequence.

Collimate
 A_0







```

OFFSET-MEASUREMENT
HR: 110°20'30"
HD: 56.789 m
NEXT --- --- ---

```

```

OFFSET-MEASUREMENT
HR: 113°30'50"
HD: 56.789 m
NEXT --- --- ---

```

```

OFFSET-MEASUREMENT
HR: 113°20'30"
VD: 3.456 m
NEXT --- --- ---

```

```

OFFSET-MEASUREMENT
HR: 113°20'30"
SD: 56.894 m
NEXT --- --- ---

```

```

OFFSET-MEASUREMENT
HR: 113°20'30"
N : -12.345 m
NEXT --- --- ---

```

- To return to procedure 4, press the **{F1}** (NEXT) key.
- To return to the previous mode, press the **{ESC}** key.
- Press the **{F3}** (NP/P) key after the step 3 to change target type.

4.7.2 Distance Offset Measurement

The measurement of a place apart from a prism is possible by inputting offset horizontal distance of front and back / right and left.

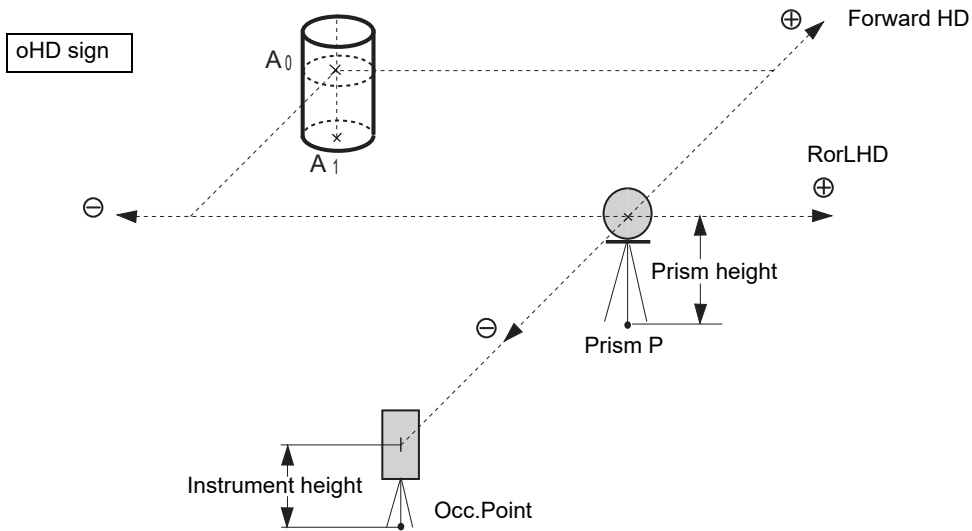

When measuring coordinates of ground point A₁: Set the instrument height / prism height.
 When measuring coordinates of point A₀: Set the instrument height only.
 (Set the prism height to 0).

Operating procedure	Operation	Display
1 Press the {F4} (P1↓) key from distance measuring mode to get the function on page 2.	{F4}	<pre> HR: 120°30'40" HD: 123.456 m VD: 5.678 m MEAS MODE NP/P P1↓ OFFSET S.O S/A P2↓ </pre>
2 Press the {F1} (OFFSET) key.	{F1}	<pre> OFFSET 1/2 F1:ANG. OFFSET F2:DIST. OFFSET F3:PLANE OFFSET P↓ </pre>
3 Press the {F2} (DIST. OFFSET) key.	{F2}	<pre> DISTANCE OFFSET INPUT RorL HD oHD= m --- --- [CLR] [ENT] </pre>
4 Enter Right and Left direction offset value, and press the {F4} (ENTER) key.	Enter HD {F4}	<pre> DISTANCE OFFSET INPUT FORWARD HD oHD= m --- --- [CLR] [ENT] </pre>
5 Enter Forward direction offset value, and press the {F4} (ENTER) key.	Enter HD {F4}	<pre> DISTANCE OFFSET HR: 80°30'40" HD: m MEAS --- NP/P --- </pre>
6 Collimate prism P, and press the {F1} (MEAS) key. Measuring will start.	Collimate P1 {F1}	<pre> DISTANCE OFFSET HR: 80°30'40" HD* [n] << m >Measuring... </pre>

After the measurement, the result which includes offset value will be shown.

- 7 Show the relative elevation of point P0.
- Each time pressing the  key, horizontal distance, relative elevation and slope distance are shown in sequence.

- Show coordinate of point P0.



DISTANCE OFFSET
HR: 80°30'40"
HD* 10.000 m
NEXT --- --- ---



DISTANCE OFFSET
HR: 80°30'40"
VD: 11.789 m
NEXT --- --- ---



DISTANCE OFFSET
HR: 80°30'40"
SD: 11.789 m
NEXT --- --- ---

N : 12.345 m
E : 23.345 m
Z : 1.345 m
NEXT --- --- ---

- To return to procedure 4, press **{F1}** (NEXT) key.
- To return to the previous mode, press **{ESC}** key.
- Press the **{F3}** (NP/P) key after the step 3 to change target type.

4.7.3 Plane Offset Measurement

Measuring will be taken for the place where direct measuring can not be done, for example distance or coordinate measuring for a edge of a plane.

Three random prism points (P1, P2, P3) on a plane will be measured at first in the plane offset measurement to determine the measured plane. Collimate the measuring target point (P0) then the instrument calculates and displays coordinate and distance value of cross point between collimation axis and of the plane.

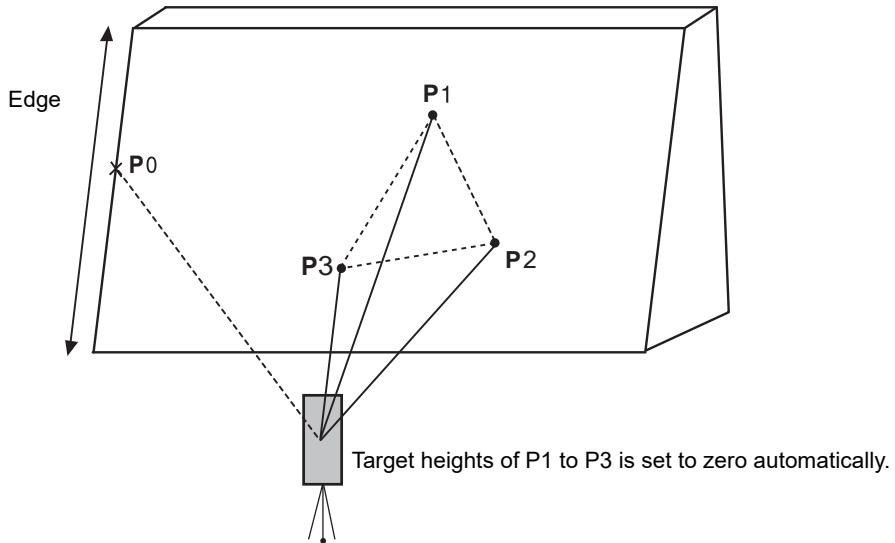

☞ When setting the coordinate value for the occupied station, refer to Section 5.1 "Setting Coordinate Values of Occupied Point".

Example: Non-prism measurement

Operating procedure	Operation	Display
1 Press the {F4} (P1↓) key from distance measuring mode to get the function on page 2.	{F4}	<pre> HR: 120° 30' 40" HD: 123.456 m VD: 5.678 m MEAS MODE NP/P P1↓ OFFSET S.O S/A P2↓ </pre>
2 Press the {F1} (OFFSET) key.	{F1}	<pre> OFFSET 1/2 F1:ANG. OFFSET F2:DIST. OFFSET F3:PLANE OFFSET P↓ </pre>
3 Press the {F3} (PLANE OFFSET) key.	{F3}	<pre> PLANE N001#: SD: m MEAS --- NP/P --- </pre>
4 Press the {F3} (NP/P) key to change to the Non-prism mode.	{F3}	<pre> PLANE N001#: N P SD: m MEAS --- NP/P --- </pre>
5 Collimate first point P1, and press the {F1} (MEAS) key. N-time measuring will start. After measuring, the display will show the second point measurement.	Collimate P1 {F1}	<pre> PLANE N001#: N P SD* [n] << m >Measuring... </pre> <p style="text-align: center;">↓</p>

- 6** Measure the second and third points in the same way.

Collimate
P2
{F1}

```

PLANE
N002#: N
          P
SD: m
MEAS --- NP/P ---
  
```

Collimate
P3
{F1}

```

PLANE
N003#: N
          P
SD: m
MEAS --- NP/P ---
  
```

The instrument calculates and displays coordinate and distance value of cross point between collimation axis and of the plane. *1), 2)

```

HR: 80°30'40"
HD: 54.321 m N
          P
VD: 10.000 m
EXIT
  
```



- 7** Collimate the edge (P0) of the plane. *3), 4)

Collimate
P0

```

HR: 75°30'40"
HD: 54.600 m N
          P
VD: -0.487 m
EXIT
  
```

- 8** To show the slope distance (SD), press the {} key.

- Each time pressing the {} key, horizontal distance, relative elevation and slope distance are shown in sequence.
- To show coordinate of point P0, press the {} key.

```

V : 90°30'40"
HR: 75°30'40" N
          P
SD: 56.602 m
EXIT
  
```

- 9** To escape the measuring, press the {F1} (EXIT) key. The display returns to the previous mode.

*1) In case the calculation of plane was not successful by the measured three points, error displays. Start measuring over again from the first point.

*2) The data is displayed in the mode selected before entering the offset measurement mode.

*3) Error will be displayed when collimated to the direction which does not cross with the determined plane.

*4) The point height of the target point P0 is set to zero automatically.

4.7.4 Column Offset Measurement

If it is possible to measure circumscription point (P1) of column directly, the distance to the center of the column (P0), coordinate and direction angle can be calculated by measured circumscription points (P2) and (P3).

The direction angle of the center of the column is 1/2 of total direction angle of circumscription points (P2) and (P3).

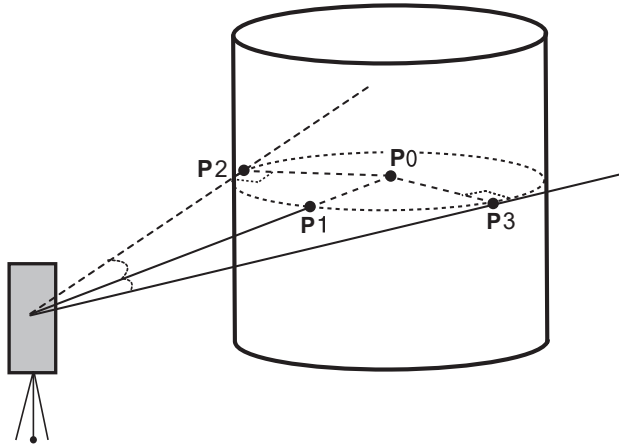

☞ When setting the coordinate value for the occupied station, refer to Section 5.1 "Setting Coordinate Values of Occupied Point".

Example: Non-prism measurement



Operating procedure	Operation	Display										
1 Press the {F4} (P1↓) key from distance measuring mode to get the function on page 2.	{F4}	<table border="1"> <tr><td>HR:</td><td>120° 30' 40"</td></tr> <tr><td>HD:</td><td>123.456 m</td></tr> <tr><td>VD:</td><td>5.678 m</td></tr> <tr><td>MEAS MODE</td><td>NP/P P1↓</td></tr> <tr><td>OFFSET S.O</td><td>S/A P2↓</td></tr> </table>	HR:	120° 30' 40"	HD:	123.456 m	VD:	5.678 m	MEAS MODE	NP/P P1↓	OFFSET S.O	S/A P2↓
HR:	120° 30' 40"											
HD:	123.456 m											
VD:	5.678 m											
MEAS MODE	NP/P P1↓											
OFFSET S.O	S/A P2↓											
2 Press the {F1} (OFFSET) key.	{F1}	<table border="1"> <tr><td>OFFSET</td><td>1/2</td></tr> <tr><td>F1:ANG. OFFSET</td><td></td></tr> <tr><td>F2:DIST. OFFSET</td><td></td></tr> <tr><td>F3:PLANE OFFSET</td><td>P↓</td></tr> </table>	OFFSET	1/2	F1:ANG. OFFSET		F2:DIST. OFFSET		F3:PLANE OFFSET	P↓		
OFFSET	1/2											
F1:ANG. OFFSET												
F2:DIST. OFFSET												
F3:PLANE OFFSET	P↓											
3 Press the {F4} (P↓) key.	{F4}	<table border="1"> <tr><td>OFFSET</td><td>2/2</td></tr> <tr><td>F1:COLUMN OFFSET</td><td></td></tr> <tr><td></td><td>P↓</td></tr> </table>	OFFSET	2/2	F1:COLUMN OFFSET			P↓				
OFFSET	2/2											
F1:COLUMN OFFSET												
	P↓											
4 Press the {F1} (COLUMN OFFSET) key.	{F1}	<table border="1"> <tr><td>COLUMN OFFSET</td><td></td></tr> <tr><td>Center</td><td></td></tr> <tr><td>HD:</td><td>m</td></tr> <tr><td>MEAS --- NP/P ---</td><td></td></tr> </table>	COLUMN OFFSET		Center		HD:	m	MEAS --- NP/P ---			
COLUMN OFFSET												
Center												
HD:	m											
MEAS --- NP/P ---												
5 Press the {F3} (NP/P) key to change to the Non-prism mode.	{F3}	<table border="1"> <tr><td>COLUMN OFFSET</td><td></td></tr> <tr><td>Center</td><td>N P</td></tr> <tr><td>HD:</td><td>m</td></tr> <tr><td>MEAS --- NP/P ---</td><td></td></tr> </table>	COLUMN OFFSET		Center	N P	HD:	m	MEAS --- NP/P ---			
COLUMN OFFSET												
Center	N P											
HD:	m											
MEAS --- NP/P ---												

6 Collimate the center of the column (P1) and press the **{F1}** (MEAS) key.
N-time measuring will start.
After the measurement, angle measuring display of the left side (P2) will be shown.

7 Collimate the left side of the column (P2) and press the **{F4}** (SET) key.
After the measurement, angle measuring display of the right side (P3) will be shown.

8 Collimate the right side of the column (P3) and press the **{F4}** (SET) key.

The distance between the instrument and center of the column (P0) will be calculated.

9 To show the relative elevation (VD), press the **{}** key.
Each time pressing the **{}** key, horizontal distance, relative elevation and slope distance are shown in sequence.

- To show coordinate of point P0, press the **{}** key.

10 To escape the measuring, press the **{ESC}** key.
The display returns to the previous mode.

Collimate
P1
{F1}

```

COLUMN OFFSET
Center                N P
HD* [n]              << m
>Measuring...
  
```

Collimate
P2
{F4}

```

COLUMN OFFSET
Left                  N P
HR: 120°30'40"
---  ---  ---  SET
  
```

Collimate
P3
{F4}

```

COLUMN OFFSET
Right                 N P
HR: 180°30'40"
---  ---  ---  SET
  
```

```

COLUMN OFFSET
HR: 150°30'40"      N P
HD: 43.321 m
NEXT ---  ---  ---
  
```

{}

```

COLUMN OFFSET
HR: 150°30'40"      N P
VD: 2.321 m
NEXT ---  ---  ---
  
```

5 COORDINATE MEASUREMENT

5.1 Setting Coordinate Values of Occupied Point

By setting the coordinates of the instrument (occupied point) based on the coordinate origin, the unknown point (prism point) coordinates based on the coordinate origin are calculated and displayed. It is possible to retain the coordinates of the occupied point after turning the power off.

☞ Refer to Chapter 17 "SELECTING MODE".

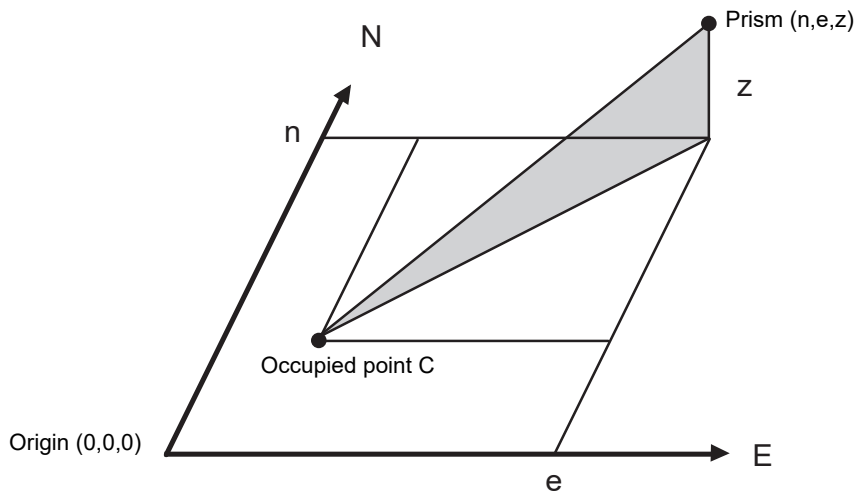

Operating procedure	Operation	Display
1 Press the {F4} (↓) key from the coordinate measurement mode to get the function on page 2.	{F4}	<pre> N: 123.456 m E: 34.567 m Z: 78.912 m MEAS MODE NP/P P1↓ R.HT INSHT OCC P2↓ </pre>
2 Press the {F3} (OCC) key.	{F3}	<pre> N= 0.000 m E: 0.000 m Z: 0.000 m --- --- [CLR] [ENT] </pre>
3 Enter N coordinate value. *1)	Enter data {F4}	<pre> N: -72.000 m E= 0.000 m Z: 0.000 m --- --- [CLR] [ENT] </pre>
4 Enter E and Z coordinate values in the same manner. After entering the values, the display returns coordinate measuring display.		<pre> N: 51.456 m E: 34.567 m Z: 78.912 m MEAS MODE NP/P P1↓ </pre>
<p>*1) ☞ Refer to Section 2.4 "How to Enter Alphanumeric Characters".</p> <ul style="list-style-type: none"> ● Input range $-99999999.9999 \leq N,E,Z \leq 99999999.9999$ m $-99999999.999 \leq N,E,Z \leq 99999999.999$ ft. $-99999999.11.7 \leq N,E,Z \leq 99999999.11.7$ ft.+inch 		

5.2 Setting Height of the Instrument

It is possible to retain the height of instrument after turning the power off.

☞ Refer to Chapter 17 "SELECTING MODE".

Operating procedure	Operation	Display
1 Press the {F4} (↓) key from the coordinate measurement mode to get the function on page 2.	{F4}	<pre> N: 123.456 m E: 34.567 m Z: 78.912 m MEAS MODE NP/P P1↓ R.HT INSHT OCC P2↓ </pre>
2 Press the {F2} (INSHT) key. The current value is displayed.	{F2}	<pre> INSTRUMENT HEIGHT INPUT INS.HT=0.000 m --- --- [CLR] [ENT] </pre>
3 Enter the instrument height. *1)	Enter Inst.HT {F4}	<pre> N: 123.456 m E: 34.567 m Z: 78.912 m MEAS MODE NP/P P1↓ </pre>
<p>*1) ☞ Refer to Section 2.4 "How to Enter Alphanumeric Characters".</p> <ul style="list-style-type: none"> Input range $-999.9999 \leq$ Instrument height ≤ 999.9999 m $-999.999 \leq$ Instrument height ≤ 999.999 ft. $-999.11.7 \leq$ Instrument height $\leq 999.11.7$ ft.+inch 		

5.3 Setting Height of Target (Prism Height)

This mode can be used to obtain Z coordinate values. It is possible to retain the height of target after turning the power off. ☞ Refer to Chapter 17 "SELECTING MODE".

Operating procedure	Operation	Display
1 Press the {F4} (↓) key from the coordinate measurement mode to get the function on page 2.	{F4}	<pre> N: 123.456 m E: 34.567 m Z: 78.912 m MEAS MODE NP/P P1↓ R.HT INSHT OCC P2↓ </pre>
2 Press the {F1} (R.HT) key. The current value is displayed.	{F1}	<pre> REFLECTOR HEIGHT INPUT R.HT =0.000 m --- --- [CLR] [ENT] </pre>
3 Enter the prism height. *1)	Enter R. HT {F4}	<pre> N: 123.456 m E: 34.567 m Z: 78.912 m MEAS MODE NP/P P1↓ </pre>
<p>*1) ☞ Refer to Section 2.4 "How to Enter Alphanumeric Characters".</p> <ul style="list-style-type: none"> Input range $-999.9999 \leq$ Prism height ≤ 999.9999 m $-999.999 \leq$ Prism height ≤ 999.999 ft. $-999.11.7 \leq$ Prism height $\leq 999.11.7$ ft.+inch 		

5.4 Execution of Coordinate Measuring

Measure the coordinates by entering the instrument height and prism height, coordinates of unknown point will be measured directly.

☞ When setting coordinate values of occupied point, see Section 5.1 "Setting Coordinate Values of Occupied Point"

☞ When setting the instrument height and prism height, see Section 5.2 "Setting Height of the Instrument" and 5.3 "Setting Height of Target (Prism Height)".

The coordinates of the unknown point are calculated as shown below and displayed:

Coordinates of occupied point : (N_0, E_0, Z_0)
 Instrument height : INS.HT
 Prism height : R.HT
 Vertical distance (Relative elevation) : z (VD)
 Coordinates of the center of the prism,
 originated from the center point of the instrument : (n, e, z)
 Coordinates of unknown point : (N_1, E_1, Z_1)
 $N_1 = N_0 + n$
 $E_1 = E_0 + e$
 $Z_1 = Z_0 + \text{INS.HT} + z - \text{R.HT}$

Coordinates of the center of the prism, originated from the center point of the instrument (n, e, z)

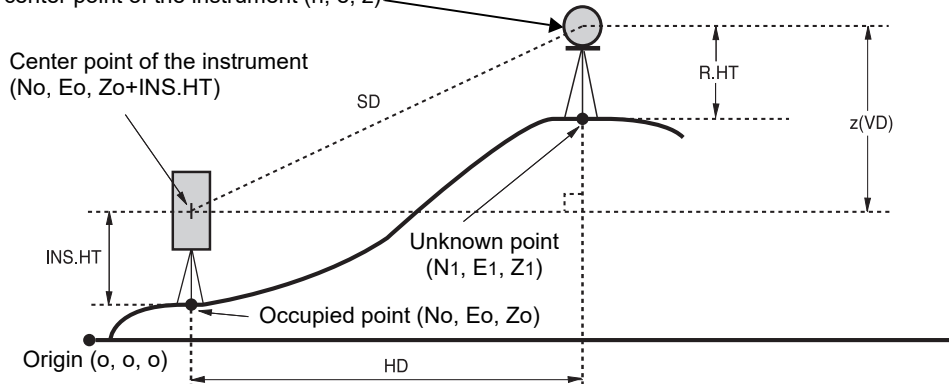

Operating procedure	Operation	Display
1 Set the direction angle of known point A. *1)	Set direction angle	V : 90°10'20" HR : 120°30'40"
2 Collimate target prism.	Collimate P	OSET HOLD HSET P1 ↓
3 Press the $\{\downarrow\}$ key. Measuring starts.	$\{\downarrow\}$	N* [r] << m E : m Z : m MEAS MODE NP/P P1 ↓
The result will be shown.		↓ N* 123.456 m E : 34.567 m Z : 78.912 m MEAS MODE NP/P P1 ↓

*1) ☞ Refer to Section 3.3 "Measuring from the Required Horizontal Angle".

- In case the coordinate of instrument point is not entered, (0,0,0) will be used as the default for the instrument point.
The instrument height will be calculated as 0 when the instrument height is not entered.
- The prism height will be calculated as 0 when the prism height is not set.

6 SPECIAL MODE (Menu Mode)

By pressing the **{MENU}** key, the instrument will be in MENU mode.
In this mode, special measuring, setting and adjustment are possible.

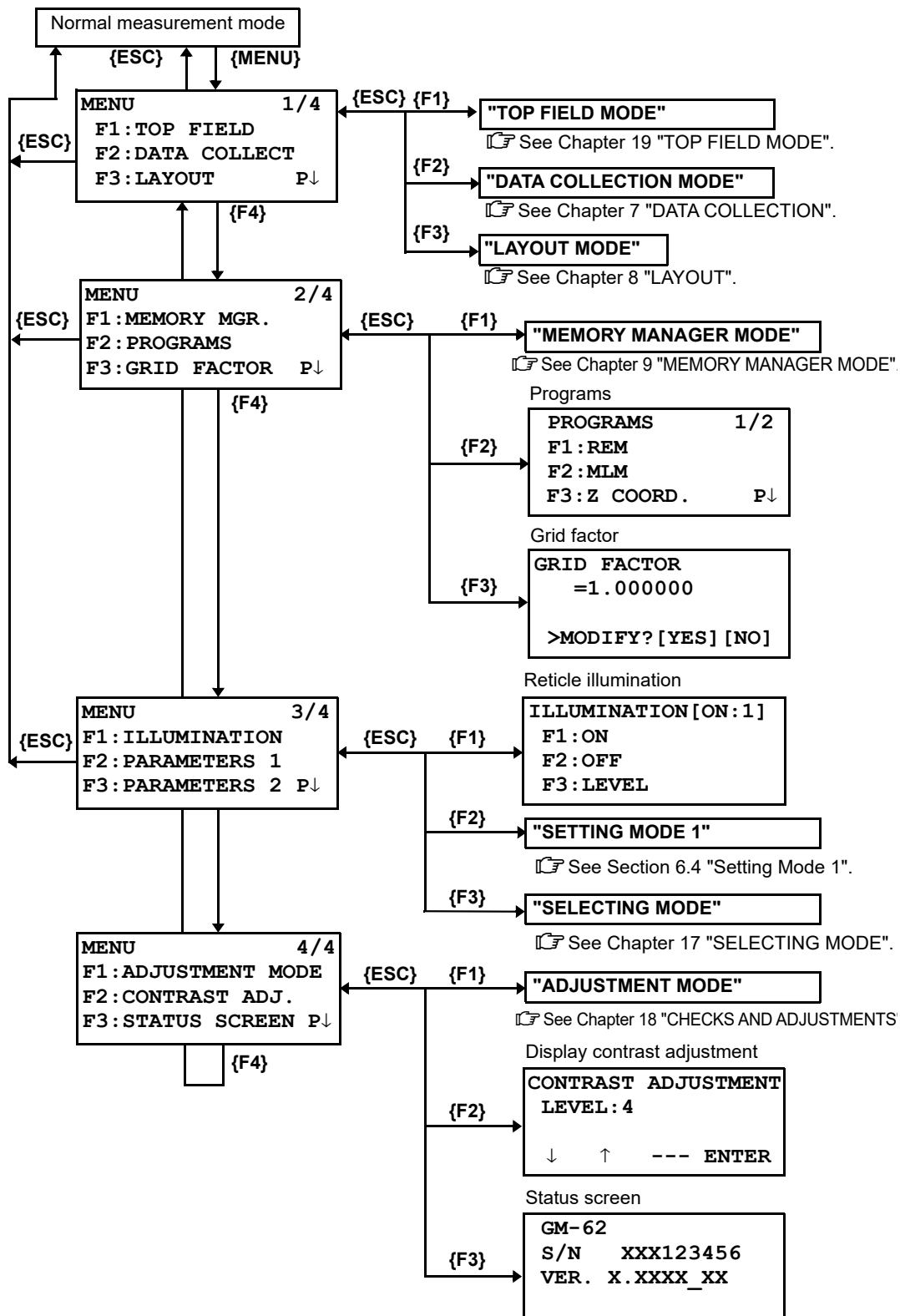

6.1 Application Measurement (PROGRAMS)

6.1.1 Remote Elevation measurement (REM)

To obtain elevation of the point at which setting the target prism is not possible, place the prism at any point on the vertical line from the target then carry out REM procedure as follows.

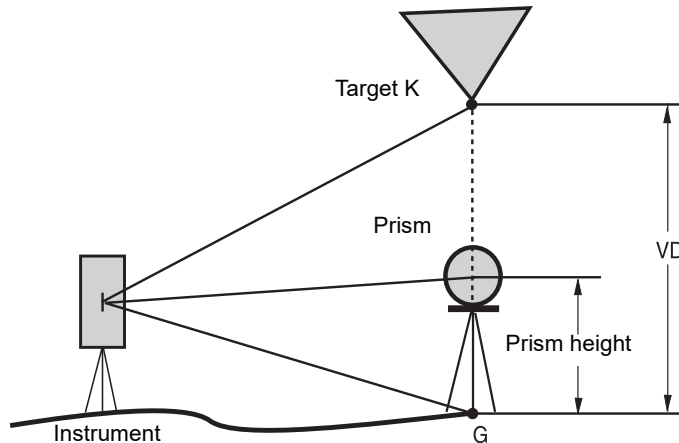

- 1) With prism height (h) input (Example:h=1.5 m)

Operating procedure	Operation	Display
1 After pressing the {MENU} key, press the {F4} (P↓) key to get the menu on page 2.	{MENU} {F4}	MENU 2/4 F1:MEMORY MGR. F2:PROGRAMS F3:GRID FACTOR P↓
2 Press the {F2} key.	{F2}	PROGRAMS 1/2 F1:REM F2:MLM F3:Z COORD. P↓
3 Press the {F1} (REM) key.	{F1}	REM F1:INPUT R.HT F2:NO R.HT
4 Press the {F1} key.	{F1}	REM-1 <STEP-1> R.HT = 0.000 m --- [CLR] [ENT]
5 Enter prism height. *1)	Enter R.HT {F4}	REM-1 <STEP-2> HD: m MEAS --- NP/P ---
6 Collimate prism.	Collimate P	
7 Press the {F1} (MEAS) key. Measuring starts.	{F1}	REM-1 <STEP-2> HD* [n] << m >Measuring...

Horizontal distance (HD) between the instrument and prism will be shown.	Collimate K	<pre>REM-1 <STEP-2> HD* 123.456 m >Measuring...</pre>
8 Collimate target K. Vertical distance (VD) will be shown. *2),3)		<pre>REM-1 VD: 1.500 m --- R.HT HD ---</pre>
		<pre>REM-1 VD: 10.456 m --- R.HT HD ---</pre>
<p>*1)  Refer to Section 2.4 "How to Enter Alphanumeric Characters".</p> <p>*2) To return to procedure 5, press the {F2} (R.HT) key. To return to procedure 6, press the {F3} (HD) key.</p> <p>*3) To return to PROGRAMS Menu, press the {ESC} key.</p>		

2) Without prism height input

Operating procedure	Operation	Display
1 After pressing the {MENU} key, press the {F4} (P↓) key to get the menu on page 2.	{MENU} {F4}	<pre>MENU 2/4 F1:MEMORY MGR. F2:PROGRAMS F3:GRID FACTOR P↓</pre>
2 Press the {F2} key.	{F2}	<pre>PROGRAMS 1/2 F1:REM F2:MLM F3:Z COORD. P↓</pre>
3 Press the {F1} (REM) key.	{F1}	<pre>REM F1:INPUT R.HT F2:NO R.HT</pre>
4 Press the {F2} key.	{F2}	<pre>REM-2 <STEP-1> HD: m MEAS --- NP/P ---</pre>
5 Collimate prism.	Collimate P	
6 Press the {F1} (MEAS) key. Measuring starts.		{F1}
Horizontal distance (HD) between the instrument and prism will be shown.		<pre>REM-2 <STEP-1> HD* 123.456 m >Measuring...</pre>

The prism position will be decided.	Collimate G	<pre> REM-2 <STEP-2> V : 60°45'50" --- --- --- SET </pre>
7 Collimate ground point G.	Collimate G	<pre> REM-2 <STEP-2> V : 123°45'50" --- --- --- SET </pre>
8 Press the {F4} (SET) key. The position of point G will be decided. *1)	{F4}	<pre> REM-2 VD: 0.000 m --- V HD --- </pre>
9 Collimate target K. Vertical distance (VD) will be shown. *2)	Collimate K	<pre> REM-2 VD: 10.456 m --- V HD --- </pre>
<p>*1) To return to procedure 5, press the {F3} (HD) key. To return to procedure 7, press the {F2} (V) key.</p> <p>*2) To return to PROGRAMS Menu, press the {ESC} key.</p>		

6.1.2 Missing Line Measurement (MLM)

Measurement for horizontal distance (dHD), slope distance (dSD), elevation (dVD) and horizontal bearing (HR) between two target prisms.

It is possible to enter the coordinate value directly or calculate from coordinate data file.

MLM mode has two modes.

- 1: MLM-1 (A-B, A-C) :Measurement is A-B, A-C, A-D,.....
- 2: MLM-2 (A-B, B-C) :Measurement is A-B, B-C, C-D,.....

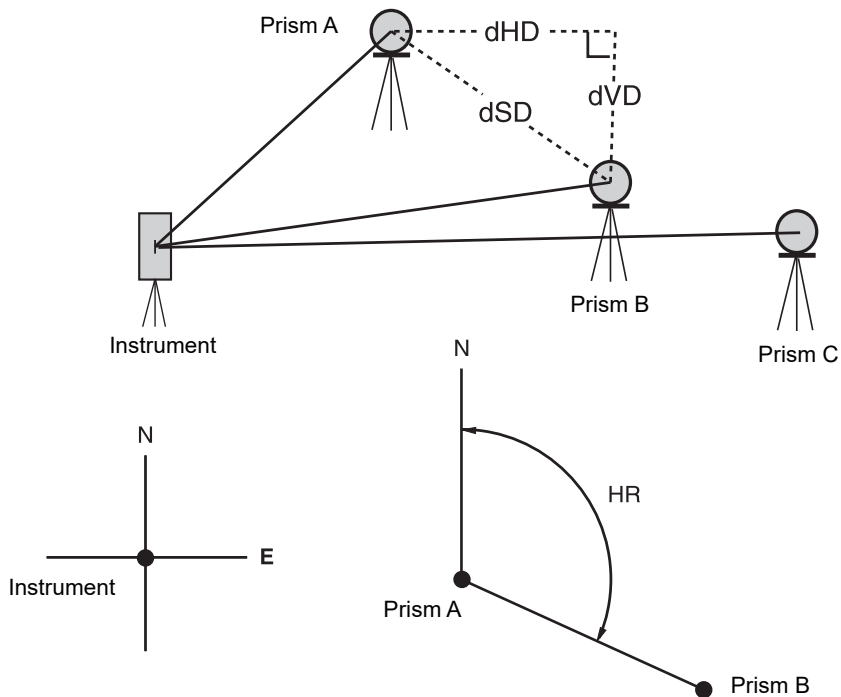

- It is necessary to set the direction angle of the instrument.

[Example] MLM-1 (A-B, A-C)

- Procedure of MLM-2 (A-B, B-C) mode is completely same as MLM-1 mode

Operating procedure	Operation	Display
1 After pressing the {MENU} key, press the {F4} (P↓) key to get the menu on page 2.	{MENU} {F4}	MENU 2 / 4 F1 : MEMORY MGR. F2 : PROGRAMS F3 : GRID FACTOR P↓
2 Press the {F2} key.	{F2}	PROGRAMS 1 / 2 F1 : REM F2 : MLM F3 : Z COORD. P↓
3 Press the {F2} (MLM) key.	{F2}	MLM F1 : USE FILE F2 : DON' T USE
4 Press the {F1} or {F2} key to select using coordinate file. [Example:F2 : DON'T USE]	{F2}	GRID FACTOR F1 : USE G. F. F2 : DON' T USE

- 5** Press the **{F1}** or **{F2}** key to select using GRID FACTOR.
[Example:F2 : DON'T USE]

- 6** Press the **{F1}** key.

- 7** Collimate prism A, and press the **{F1}** (MEAS) key. Horizontal distance (HD) between the instrument and prism A will be shown.

The prism position will be decided.

- 8** Collimate prism B and press the **{F1}** (MEAS) key. Horizontal distance (HD) between the instrument and prism B will be shown.

The horizontal distance (dHD) and relative elevation (dVD) between prism A and B.

- 9** To show slope distance (dSD), press **{** key.

- 10** To measure the distance between points A and C, press the **{F3}** (HD). *1)

- 11** Collimate point C (Prism C) and press the **{F1}** (MEAS) key. Horizontal distance (HD) between the instrument and prism C will be shown.

{F2}

```
MLM
F1:MLM-1 (A-B, A-C)
F2:MLM-2 (A-B, B-C)
```

{F1}

```
MLM-1 (A-B, A-C)
<STEP-1>
HD:                m
MEAS  R.HT  NEZ  NP/P
```

Collimate A
{F1}

```
MLM-1 (A-B, A-C)
<STEP-1>
HD* [n]            << m
MEAS  R.HT  NEZ  NP/P
```

↓

```
MLM-1 (A-B, A-C)
<STEP-1>
HD*  123.456 m
MEAS  R.HT  NEZ  NP/P
```

```
MLM-1 (A-B, A-C)
<STEP-2>
HD:                m
MEAS  R.HT  NEZ  NP/P
```

Collimate B
{F1}

```
MLM-1 (A-B, A-C)
<STEP-2>
HD* [n]            << m
MEAS  R.HT  NEZ  NP/P
```

↓

```
MLM-1 (A-B, A-C)
<STEP-2>
HD*  345.678 m
MEAS  R.HT  NEZ  NP/P
```

```
MLM-1 (A-B, A-C)
dHD : 123.456 m
dVD :  12.345 m
----  ----  HD  ----
```

{

```
MLM-1 (A-B, A-C)
dSD : 124.072 m
HR  : 12°34'40"
----  ----  HD  ----
```

{F3}

```
MLM-1 (A-B, A-C)
<STEP-2>
HD:                m
MEAS  R.HT  NEZ  NP/P
```

Collimate
prism C
{F1}

The horizontal distance (dHD) and relative elevation (dVD) between prism A and C.

```

MLM-1 (A-B, A-C)
dHD : 234.567 m
dVD : 23.456 m
--- --- HD ---

```

12 To measure the distance between points A and D, repeat procedure 12 to 14. *1)

*1) To return to previous mode, press the **{ESC}** key.

● How to use coordinate data

It is possible to input coordinate value directly or calculate from coordinate data file

Operating procedure	Operation	Display
<p>To use coordinate data file, select "USE FILE" in step 4.</p> <p>After procedure 6.</p> <p>1 Press the {F3} (NEZ) key. Direct key input display will be shown.</p>	{F3}	<pre> MLM-1 (A-B, A-C) <STEP-1> HD: m MEAS R.HT NEZ NP/P </pre>
<p>2 Press the {F3} (PT#) key to use coordinate data file. Point number input display will be shown. Pressing the {F3} (HD) key, the display will return to procedure 6.</p> <p>After selecting coordinate input mode by pressing the {F3} (NEZ or PT# or HD) key, press the {F1} (INPUT) key and enter the data.</p>	{F3}	<pre> MLM-1 (A-B, A-C) PT#: _____ INPUT LIST HD ENTER </pre>

6.1.3 Setting Z Coordinate of Occupied Point

Occupied point coordinate data and known point actual measuring data are utilized, z coordinate of occupied point is calculated and reset again.
Known point data and coordinate data can use the coordinate data file.

1) Setting occupied coordinate

[Example setting] Using coordinate data file.

Operating procedure	Operation	Display
1 After pressing {MENU} key, press {F4} (P↓) key to get the menu on page 2.	{MENU} {F4}	MENU 2 / 4 F1: MEMORY MGR. F2: PROGRAMS F3: GRID FACTOR P↓
2 Press the {F2} key.	{F2}	PROGRAMS 1 / 2 F1: REM F2: MLM F3: Z COORD. P↓
3 Press the {F3} (Z COORD.) key.	{F3}	Z COORD. SETTING F1: USE FILE F2: DON' T USE
4 Press the {F1} (USE FILE) key.	{F1}	SELECT A FILE FN: _____ INPUT LIST --- ENTER
5 Press the {F1} (INPUT) key and enter the File Name.	{F1} Enter FN {F4}	Z COORD. SETTING F1: OCC. PT INPUT F2: REF. MEAS
6 Press the {F1} key.	{F1}	OCC. PT PT#: _____ INPUT LIST NEZ ENTER
7 Press the {F1} (INPUT) key and enter the Point number. Instrument height setting display will be shown.	{F1} Enter PT# {F4}	INSTRUMENT HEIGHT INPUT INS. HT=0.000 m --- --- [CLR] [ENT]
8 Enter the height. The display returns to Z coordinate menu.	Enter HT {F4}	Z COORD. SETTING F1: OCC. PT INPUT F2: REF. MEAS

 For more information about data file, see Chapter 9 "MEMORY MANAGER MODE".

2) Z Coordinate Calculation from Known Point Measuring Data

[Example setting] Using coordinate data file

Operating procedure	Operation	Display
1 After pressing {MENU} key, press {F4} (P↓) key to get the menu on page 2.	{MENU} {F4}	MENU 2/4 F1:MEMORY MGR. F2:PROGRAMS F3:GRID FACTOR P↓
2 Press the {F2} key.	{F2}	PROGRAMS 1/2 F1:REM F2:MLM F3:Z COORD. P↓
3 Press the {F3} (Z COORD.) key.	{F3}	Z COORD.SETTING F1:USE FILE F2:DON'T USE
4 Press the {F1} (USE FILE) key.	{F1}	SELECT A FILE FN: _____ INPUT LIST --- ENTER
5 Press the {F1} (INPUT) key and enter the File Name.	{F1} Enter FN {F4}	Z COORD.SETTING F1:OCC.PT INPUT F2:REF.MEAS
6 Press the {F2} key.	{F2}	NOO1# PT#: _____ INPUT LIST NEZ ENTER
7 Press the {F1} (INPUT) key and enter the Point Number in coordinate data file.	{F1} Enter PT# {F4}	N: 4.356 m E: 16.283 m Z: 1.553 m >OK ? [YES] [NO]
8 Press the {F3} (YES) key and enter the Point Number in coordinate data file.	{F3}	REFLECTOR HEIGHT INPUT R.HT =0.000 m --- --- [CLR] [ENT]
9 Enter the height.	Enter R. HT {F4}	REFLECTOR HEIGHT INPUT R.HT : 0.000 m MEAS --- NP/P ---
10 Collimate a prism on the point and press the {F1} (MEAS) key. Measuring starts. *1)	Collimate P {F1}	HR: 120°30'40" HD*[n] << m VD: m >Measuring...



<p>11 Press the {F4} (CALC) key.*2) Z : Z coordinate dZ: Standard deviation</p>	{F4}	<pre>HR: 120°30'40" HD: 12.345 m VD: 23.456 m NEXT --- --- CALC</pre>
<p>12 Press the {F4} (SET) key. *3) Z coordinate of the occupied point will be set. Basksight point measuring screen will be shown.</p>		{F4}
<p>13 Press the {F3} (YES) key. Horizontal angle will be set. The display returns to Programs 1/2 menu.</p>	{F3}	
		<pre>PROGRAMS 1/2 F1:REM F2:MLM F3:Z COORD. P↓</pre>
<p>*1) Measurement is Fine N-times measurement mode. *2) To measure other points, press the {F1} (NEXT) key. *3) Pressing the {F3} key, the display will be changed alternately.</p>		

6.1.4 Area Calculation

This mode calculate the area of a closed figure.
There are two area calculation methods as follows.

- 1) Area Calculation from Coordinate data file
- 2) Area Calculation from Measured data



- Area is not calculated correctly if enclosed lines cross each other.
- It is impossible to calculate what a mix of coordinate file data and measured data.
- If the coordinate data file does not exist, the area calculation from measured data is done automatically.
- The numbers of points used to calculate are not limited.

1) Area Calculation from Coordinate Data File

Operating procedure	Operation	Display
1 After pressing the {MENU} key, press the {F4} (P↓) key to get the menu on page 2/4.	{MENU} {F4}	MENU 2/4 F1:MEMORY MGR. F2:PROGRAMS F3:GRID FACTOR P↓
2 Press the {F2} key.	{F2}	PROGRAMS 1/2 F1:REM F2:MLM F3:Z COORD. P↓
3 Press the {F4} (P↓) key to get the PROGRAMS menu on page 2/2.	{F4}	PROGRAMS 2/2 F1:AREA F2:POINT TO LINE F3:ROAD P↓
4 Press the {F1} (AREA) key.	{F1}	AREA F1:FILE DATA F2:MEASUREMENT
5 Press the {F1} (FILE DATA) key.	{F1}	SELECT A FILE FN: _____ INPUT LIST --- ENTER
6 Press the {F1} (INPUT) key and enter the File Name. Initial display will be shown.	{F1} Enter FN {F4}	AREA 0000 m.sq NEXT# :DATA-01 PT# LIST UNIT NEXT
7 Press the {F4} (NEXT) key. *1),2) The top of the file data (DATA-01) will be set and the second point number will be shown.	{F4}	AREA 0001 m.sq NEXT# :DATA-02 PT# LIST UNIT NEXT
8 Repeat pressing the {F4} (NEXT) key to set required number of points.	{F4}	⋮

When 3 or more points are set, the area surrounded by the points is calculated and the result will be shown.

```

AREA          0021
              123.456 m.sq
NEXT# :DATA-22
PT#  LIST  UNIT NEXT
    
```

- *1) To set specify point, press the {F1} (PT#) key.
- *2) To show the list of the coordinate data in the file, press the {F2} (LIST) key.

2) Area Calculation from Measured Data

Operating procedure	Operation	Display
1 After pressing the {MENU} key, press the {F4} (P↓) key to get the menu on page 2/4.	{MENU} {F4}	<pre> MENU 2/4 F1:MEMORY MGR. F2:PROGRAMS F3:GRID FACTOR P↓ </pre>
2 Press the {F2} key.	{F2}	<pre> PROGRAMS 1/2 F1:REM F2:MLM F3:Z COORD. P↓ </pre>
3 Press the {F4} (P↓) key to get the PROGRAMS menu on page 2/2.	{F4}	<pre> PROGRAMS 2/2 F1:AREA F2:POINT TO LINE F3:ROAD P↓ </pre>
4 Press the {F1} (AREA) key.	{F1}	<pre> AREA F1:FILE DATA F2:MEASUREMENT </pre>
5 Press the {F2} (MEASUREMENT) key.	{F2}	<pre> AREA F1:USE G.F. F2:DON'T USE </pre>
6 Press the {F1} or {F2} key to select using GRID FACTOR. [Example:F2 : DON'T USE]	{F2}	<pre> AREA 0000 m.sq MEAS --- UNIT NP/P </pre>
7 Collimate a prism and press the {F1} (MEAS) key. Measuring starts. *1)	Collimate P {F1}	<pre> N*[n] <<< m E: m Z: m >Measuring... </pre> <p style="text-align: center;">↓</p> <pre> AREA 0001 m.sq MEAS --- UNIT NP/P </pre>
8 Collimate next point and press the {F1} (MEAS) key.	Collimate {F1}	<p>⋮</p>

When 3 or more points are measured, the area surrounded by the points is calculated and the result will be shown.

AREA	0003
234.567 m.sq	
MEAS --- UNIT NP/P	

*1) Measurement is Fine N-times measurement mode.

● To change the display unit

It is possible to change the displayed area unit.

Operating procedure	Operation	Display						
1 Press the {F3} (UNIT) key.	{F3}	<table border="1"> <tr> <td>AREA</td> <td>0003</td> </tr> <tr> <td>100.000 m.sq</td> <td></td> </tr> <tr> <td>MEAS --- UNIT NP/P</td> <td></td> </tr> </table>	AREA	0003	100.000 m.sq		MEAS --- UNIT NP/P	
		AREA	0003					
100.000 m.sq								
MEAS --- UNIT NP/P								
2 Select a unit by pressing the {F1} to {F4} key. Example: {F2} (ha) key.	{F2}	<table border="1"> <tr> <td>AREA</td> <td>0003</td> </tr> <tr> <td>100.000 m.sq</td> <td></td> </tr> <tr> <td>m.sq ha ft.sq acre</td> <td></td> </tr> </table>	AREA	0003	100.000 m.sq		m.sq ha ft.sq acre	
		AREA	0003					
100.000 m.sq								
m.sq ha ft.sq acre								
		<table border="1"> <tr> <td>AREA</td> <td>0003</td> </tr> <tr> <td>0.010 ha</td> <td></td> </tr> <tr> <td>MEAS --- UNIT NP/P</td> <td></td> </tr> </table>	AREA	0003	0.010 ha		MEAS --- UNIT NP/P	
AREA	0003							
0.010 ha								
MEAS --- UNIT NP/P								
<ul style="list-style-type: none"> m.sq: square meter ha: hectare ft.sq: square feet acre: acre. 								

6.1.5 Point to Line Measurement

This mode is used to obtain the coordinate data with the origin point A(0,0,0) and the line AB as N axis. Place the 2 prisms at the points A and B on the line, and place the instrument at unknown point C. After measuring the 2 prisms, the coordinate data and the direction angle of the instrument will be calculated and restored.

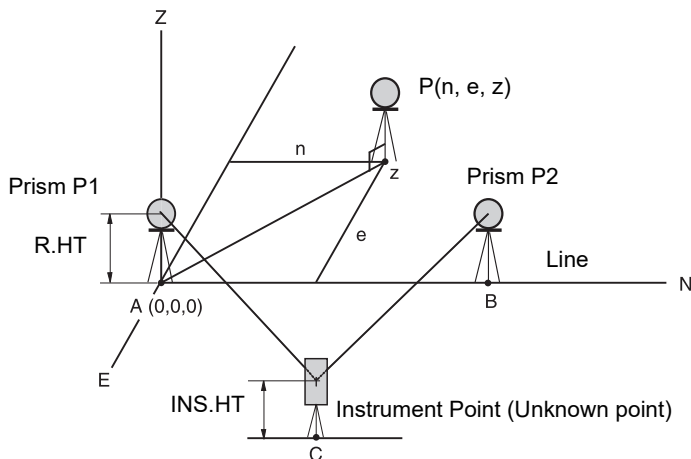

Operating procedure	Operation	Display
1 After pressing the {MENU} key, press the {F4} (P↓) key to get the menu on page 2/4.	{MENU} {F4}	MENU 2/4 F1: MEMORY MGR. F2: PROGRAMS F3: GRID FACTOR P↓
2 Press the {F2} key.	{F2}	PROGRAMS 1/2 F1: REM F2: MLM F3: Z COORD. P↓
3 Press the {F4} (P↓) key to get the PROGRAMS menu on page 2/2.	{F4}	PROGRAMS 2/2 F1: AREA F2: POINT TO LINE F3: ROAD P↓
4 Press the {F2} key.	{F2}	INSTRUMENT HEIGHT INPUT INS.HT=0.000 m --- --- [CLR] [ENT]
5 Enter instrument height.	Enter INS.HT {F4}	REFLECTOR HEIGHT INPUT R.HT =0.000 m --- --- [CLR] [ENT]
6 Enter reflector A(P1) height.	Enter R.HT {F4}	POINT TO LINE MEAS. P1 HD: m MEAS --- NP/P ---

<p>7 Collimate prism P1 (Origin) and press {F1} (MEAS) key. Measuring starts. *1)</p> <p>Input display of reflector B (P2) height will be shown.</p>	Collimate P1 {F1}	<pre>POINT TO LINE MEAS.P1 HD*[n] << m >Measuring...</pre>
<p>8 Enter reflector B (P2) height.</p>	Enter R. HT {F4}	<pre>REFLECTOR HEIGHT INPUT R.HT= 0.000 m --- --- [CLR] [ENT]</pre>
<p>9 Collimate prism B (P2) (Origin) and press the {F1} (MEAS) key. Measuring starts. *1)</p> <p>The coordinate data and the direction angle of the instrument are calculated and restored. The result (The distance between A and B) will be displayed. dHD: Horizontal distance dVD: Vertical distance dSD: Slope distance *2),3)</p>	Collimate P2 {F1}	<pre>POINT TO LINE MEAS.P2 HD: m MEAS --- NP/P ---</pre>
<p>10 Press {F1} (NEZ) key to measure other points.</p>	{F1}	<pre>POINT TO LINE MEAS.P2 HD*[n] << m >Measuring...</pre>
<p>11 Collimate a prism and press {F1} (MEAS) key. Coordinate measurement starts. *4) The result will be shown. *5)</p>	Collimate P {F1}	<pre>DIST. (P1-P2) 1/2 dHD: 10.000 m dVD: 0.000 m NEZ S.CO --- P↓</pre>
		<pre>N: 0.000 m E: 0.000 m Z: 0.000 m MEAS R.HT NP/P --- >Measuring...</pre>
		<pre>N: 3.456 m E: 5.432 m Z: 0.000 m MEAS R.HT NP/P ---</pre>
<p>*1) Measurement is Fine N-times measurement mode. *2) To show dSD, press {F4} (P↓) key. *3) To show the new occupied data, press {F2} (S.CO) key. *4) Measurement is Fine N-times measurement mode. *5) To return to previous mode, press the {ESC} key.</p>		

6.2 Setting the GRID FACTOR

GRID FACTOR can reset in this menu mode.

 For more information, refer to Section 8.1.1 "Setting the GRID FACTOR".

Grid Factor can be applied to the following application programs.

It is also possible to cancel the Grid factor function by selecting "DON'T USE" in "SELECTING MODE". At this time the setting and selecting screens for Grid Factor will be omitted.

- **Data collection mode**

When the NEZ automatic calculation (NEZ AUTO. CALC) is ON, Grid factor will be applied to the coordinate data (Including PTL data) recorded into a coordinate data file when the RAW data is measured and recorded. (In this case, Grid Factor is not applied to the RAW data recorded into the measured data file.)

PTL (Point To Line measurement)

When executing PTL measurement mode, the NEZ Auto Calculation will be turned on compulsorily and Grid factor will be applied to the coordinate data.

- **Layout / ROAD**

Execution Layout (Including PTL measurement mode) / ROAD

1. When displaying the difference (dHD) between grid horizontal distance to a layout point (HDg) on the projection plane and measured ground horizontal distance to a prism point (HD), Grid factor will be applied to grid distance (HDg) in order to reverse-convert grid distance to ground distance.
2. After completion of a layout point, the displayed coordinate data will be applied to grid factor in order to compare with surveying data and calculated data on the projection plane.

(NEW POINT-Side Shot)

In the side shot method, the coordinate of a new point will be applied to grid factor and it will be recorded into a coordinate data file.

(NEW POINT - Resection)

In the resection method, when the calculated coordinate of a new point is displayed or recorded, it will be applied to grid factor and be recorded into a coordinate data file.

- **MLM (Missing Line Measurement)**

When selecting grid factor "USE G.F.", measured data will be applied to grid factor. At this time, horizontal distance (dHD) and slope distance (dSD) will be on the projection plane.

- **AREA (Area calculation / Measured method)**

When selecting grid factor "USE G.F.", measured data will be applied to grid factor. At this time, the calculated area will be on the projection plane.



- Calculation of Z coordinate is not influenced even if it is applied to grid factor.

Operating procedure	Operation	Display
1 After pressing the {MENU} key, press the {F4} (P↓) key to get the menu on page 2.	{MENU} {F4}	<pre> MENU 2 / 4 F1 : MEMORY MGR. F2 : PROGRAMS F3 : GRID FACTOR P↓ </pre>
2 Press the {F3} (GRID FACTOR) key.	{F3}	<pre> GRID FACTOR =0.998843 >MODIFY? [YES] [NO] </pre>

<p>3 Press the {F3} (YES) key.</p>	<p>{F3}</p>	<pre> GRID FACTOR ELEV.=1000 m SCALE:0.999000 --- --- [CLR] [ENT] </pre>
<p>4 Enter Elevation. *1) Press the {F4} (ENT) key.</p>	<p>Enter ELEV. {F4}</p>	<pre> GRID FACTOR ELEV.:2000 m SCALE=1.001000 --- --- [CLR] [ENT] </pre>
<p>5 Enter Scale Factor in the same way.</p> <p>Grid Factor is displayed for 1 to 2 second and display returns to menu.</p>	<p>Enter Scale {F4}</p>	<pre> GRID FACTOR =1.000686 </pre>
<p>*1)  Refer to Section 2.4 "How to Enter Alphanumeric Characters".</p> <ul style="list-style-type: none"> Input Range:Elevation : -9,999 to 9,999 meter (-32,805 to 3,2805 ft, ft+in) Scale Factor: 0.990000 to 1.010000 		

6.3 Setting Illumination of Display and Cross Hairs

Setting ON/OFF/LEVEL (1 to 5) for illumination of display (LCD) and reticle.
Setting LEVEL (1 to 5) is only for reticle.
[Example setting] LEVEL:2 and turn on the illumination.

Operating procedure	Operation	Display
<p>1 After pressing the {MENU} key, press the {F4} (P↓) key twice to get the menu on page 3.</p>	<p>{MENU} {F4} {F4}</p>	<pre> MENU 3/4 F1: ILLUMINATION F2: PARAMETERS 1 F3: PARAMETERS 2 P↓ </pre>
<p>2 Press the {F1} key. The data previously set is shown.</p>	<p>{F1}</p>	<pre> ILLUMINATION [OFF:1] F1: ON F2: OFF F3: LEVEL </pre>
<p>3 Press the {F3} (LEVEL) key.</p>	<p>{F3}</p>	<pre> ILLUMINATION [OFF:1] [LEVEL MODE] ↓ ↑ --- ENTER </pre>
<p>4 Press the {F2} (↑) key, and then press the {F4} (ENTER) key.</p>	<p>{F2} {F4}</p>	<pre> ILLUMINATION [OFF:2] F1: ON F2: OFF F3: LEVEL </pre>
<p>5 Press the {F1} (ON) key.</p>	<p>{F1}</p>	<pre> ILLUMINATION [ON:2] F1: ON F2: OFF F3: LEVEL </pre>
<ul style="list-style-type: none"> To return to previous mode, press the {ESC} key. 		

6.4 Setting Mode 1

In this mode, the following settings are possible.

1. Setting minimum reading
2. Auto power off
3. Vertical and horizontal angle tilt correction (Tilt ON/OFF)
4. Systematic error of instrument correction
5. Setting for RS-232C communication
6. Selecting communication port (Only for *Bluetooth* function built-in models)
7. Confirming the *Bluetooth* device address (Only for *Bluetooth* function built-in models)
8. Setting humidity input
9. Setting NP-TRK mode
10. Setting EDM eco. mode
11. Setting volume

Note

- This setting is memorized after power off.

6.4.1 Setting Minimum Reading

Select minimum display unit for angle measurement, coarse distance measurement mode.

 To select minimum display for fine measurement mode, see Chapter 17 "SELECTING MODE" .

Models	Angle Unit			Coarse mode Distance unit
	Degree	GON	MIL	
GM-62/65	1" / 5"	0.0002 gon / 0.0010 gon	0.005 mil / 0.02 mil	Prism mode, Non-Prism mode 10 mm (0.02 ft)/1 mm (0.005 ft)

[Example] Minimum angle: 5", Coarse: 1 mm

Operating procedure	Operation	Display
1 After pressing the {MENU} key, press the {F4} (P↓) key twice to get the menu on page 3.	{MENU} {F4} {F4}	MENU 3/4 F1: ILLUMINATION F2: PARAMETERS 1 F3: PARAMETERS 2 P↓
2 Press the {F2} key.	{F2}	PARAMETERS 1 1/4 F1: MINIMUM READING F2: AUTO POWER OFF F3: TILT P↓
3 Press the {F1} key.	{F1}	MINIMUM READING F1: ANGLE F2: COARSE
4 Press the {F1} key.	{F1}	MINIMUM ANGLE [F1: 1"] F2: 5" ENTER
5 Press the {F2} (5") key and press the {F4} (ENTER) key.	{F2} {F4}	MINIMUM READING F1: ANGLE F2: COARSE

6 Press the {F2} key.	{F2}	COARSE READING F1: 1 mm [F2:10 mm] ENTER
7 Press the {F1} key and press the {F4} (ENTER) key.	{F1} {F4}	MINIMUM READING F1: ANGLE F2: COARSE
<ul style="list-style-type: none"> To return to previous mode, press the {ESC} key. 		

6.4.2 Auto Power Off

If no key operation is given or no process of measurement is performed for more than 30 minutes (No change exceeding 30" has occurred during horizontal angle or vertical angle measurement.), the power turns off automatically.

Operating procedure	Operation	Display
1 After pressing the {MENU} key, press the {F4} (P↓) key twice to get the menu on page 3.	{MENU} {F4} {F4}	MENU 3/4 F1: ILLUMINATION F2: PARAMETERS 1 F3: PARAMETERS 2 P↓
2 Press the {F2} key.	{F2}	PARAMETERS 1 1/4 F1: MINIMUM READING F2: AUTO POWER OFF F3: TILT P↓
3 Press the {F2} key. The data previously set is shown.	{F2}	AUTO POWER OFF [OFF] F1: ON F2: OFF ENTER
4 Press the {F1} (ON) key or {F2} (OFF) key, and press the {F4} (ENTER) key.	{F1} or {F2} {F4}	

6.4.3 Vertical and Horizontal Angle Tilt correction (Tilt ON/OFF)

In case the instrument is used in an unstable situation, constant indexing of vertical and horizontal angle may be impossible. In this case, the function of tilt correction can be stopped by selecting TILT OFF. It has been set to X,Y (V/H) TILT ON at the factory.



- This setting is memorized after power off.

Operating procedure	Operation	Display
1 After pressing the {MENU} key, press the {F4} (P↓) key twice to get the menu on page 3.	{MENU} {F4} {F4}	MENU 3/4 F1: ILLUMINATION F2: PARAMETERS 1 F3: PARAMETERS 2 P↓
2 Press the {F2} key.	{F2}	PARAMETERS 1 1/4 F1: MINIMUM READING F2: AUTO POWER OFF F3: TILT P↓
3 Press the {F3} key. The data previously set is shown. If already ON, the display shows tilt correction value.	{F3}	TILT SENSOR: [XY-ON] X: 0° 02' 10" Y: 0° 03' 00" X-ON XY-ON OFF ENTER
4 Press the {F1} (X-ON) key or {F2} (XY-ON) or {F3} (OFF) key, and press the {F4} (ENTER) key.	{F1} ~ {F3} {F4}	

6.4.4 Systematic Error of Instrument Correction

Setting ON/OFF for error correction of collimation and horizontal axis for angle measurement.



- Perform this item after complete Section 18.3 "Adjustment of Compensation Systematic Error of Instrument".

Operating procedure	Operation	Display
1 After pressing the {MENU} key, press the {F4} (P↓) key twice to get the menu on page 2.	{MENU} {F4} {F4}	MENU 3/4 F1: ILLUMINATION F2: PARAMETERS 1 F3: PARAMETERS 2 P↓
2 Press the {F2} key.	{F2}	PARAMETERS 1 1/4 F1: MINIMUM READING F2: AUTO POWER OFF F3: TILT P↓
3 Press the {F4} key.	{F4}	PARAMETERS 1 2/4 F1: ERROR CORRECTION F2: RS-232C F3: SELECT COM P↓

<p>4 Press the {F1} key. The data previously set is shown.</p>	{F1}	<table border="1"><tr><td>ERROR CORR.</td><td>[OFF]</td></tr><tr><td>F1 : ON</td><td></td></tr><tr><td>F2 : OFF</td><td></td></tr><tr><td></td><td>ENTER</td></tr></table>	ERROR CORR.	[OFF]	F1 : ON		F2 : OFF			ENTER
ERROR CORR.	[OFF]									
F1 : ON										
F2 : OFF										
	ENTER									
<p>5 Press the {F1} (ON) key or {F2} (OFF) key, and press the {F4} (ENTER) key.</p>	{F1} or {F2} {F4}									

6.4.5 Setting RS-232C communication with external device

you can set the parameters for RS-232C communication with external device from parameters setting menu.

The following parameters can be set.

Item	Selecting items
Baud rate	1200, 2400, 4800, 9600, 19200, 38400
Character bit (bit length)/Parity	7/Even, 7/Odd, 8/None
Stop bit	1, 2
ACK mode	Standard, Omitted
CR,LF	ON, OFF
REC type	REC-A, REC-B
Factory setting	Baud rate: 1200 baud rate, Character bit/Parity:7/Even, CRLF:OFF, REC type: REC-A, ACK:Standard

ACK mode, CRLF and REC type are interlocked with the same items in the selecting mode.

☞ Refer to 17 "SELECTING MODE"

Sample setting

STOP BITS: 2

Operating procedure	Operation	Display
1 After pressing the {MENU} key, press the {F4} (P↓) key twice to get the menu on page 2.	{MENU} {F4} {F4}	MENU 3/4 F1: ILLUMINATION F2: PARAMETERS 1 F3: PARAMETERS 2 P↓
2 Press the {F2} key.	{F2}	PARAMETERS 1 1/4 F1: MINIMUM READING F2: AUTO POWER OFF F3: TILT P↓
3 Press the {F4} key.	{F4}	PARAMETERS 1 2/4 F1: ERROR CORRECTION F2: RS-232C F3: SELECT COM P↓
4 Press the {F2} key. The data previously set is shown.	{F2}	RS-232C 1/3 F1: BAUD RATE F2: CHAR. /PARITY F3: STOP BITS P↓
5 Press the {F3} key to select STOP BITS. The data previously set is marked.	{F3}	STOP BITS [F1: 1] F2: 2 ENTER
6 Press the {F2} (2) key to select stop bit 2, and press the {F4} (ENTER) key.	{F2} {F4}	

6.4.6 Selecting Communication Port

You can change the communication port to *Bluetooth* port (*Bluetooth* function is an optional function).

Sample setting

Bluetooth

Operating procedure	Operation	Display
1 After pressing the {MENU} key, press the {F4} (P↓) key twice to get the menu on page 3.	{MENU} {F4} {F4}	MENU 3/4 F1: ILLUMINATION F2: PARAMETERS 1 F3: PARAMETERS 2 P↓
2 Press the {F2} key.	{F2}	PARAMETERS 1 1/4 F1: MINIMUM READING F2: AUTO POWER OFF F3: TILT P↓
3 Press the {F4} key.	{F4}	PARAMETERS 1 2/4 F1: ERROR CORRECTION F2: RS-232C F3: SELECT COM P↓
4 Press the {F3} key.	{F3}	SELECT COM F1: BLUETOOTH [F2: RS-232C] ENTER
5 Press the {F1} (<i>BLUETOOTH</i>) key to select the communication port and press the {F4} (ENTER) key. The display will return to the previous menu.	{F1} {F4}	SELECT COM [F1: BLUETOOTH] F2: RS-232C ENTER



- If the *Bluetooth* device for communication requires your passkey, enter "1111."

6.4.7 Confirming the *Bluetooth* Device Address (Only for *Bluetooth* function built-in models)

You can confirm the *Bluetooth* address

Operating procedure	Operation	Display
1 After pressing the {MENU} key, press the {F4} (P↓) key twice to get the menu on page 3.	{MENU} {F4} {F4}	MENU 3/4 F1: ILLUMINATION F2: PARAMETERS 1 F3: PARAMETERS 2 P↓
2 Press the {F2} key.	{F2}	PARAMETERS 1 1/4 F1: MINIMUM READING F2: AUTO POWER OFF F3: TILT P↓
3 Press the {F4} key.	{F4}	PARAMETERS 1 2/4 F1: ERROR CORRECTION F2: RS-232C F3: SELECT COM P↓
4 Press the {F4} key.	{F4}	PARAMETERS 1 3/4 F1: BLUETOOTH F2: HUMID. INPUT F3: NP-TRK. MODE P↓
5 Press the {F1} key. Register the <i>Bluetooth</i> address (ADDR.) displayed here in the paired device set as "Master".	{F1}	BLUETOOTH ADDR. : 0000E14F49B4 ENTER
6 Press the {F4} (ENTER) key.	{F4}	

- ***Bluetooth* device address**

This is a number unique to one particular *Bluetooth* device used to identify devices during communication. This number consists of 12 characters (numbers 0 to 9 and letters from A to F). Some devices may be referred to by their *Bluetooth* device address.

6.4.8 Humidity Input ON/OFF Setting

Factory setting for humidity input is "OFF". In this case, atmospheric correction factor is calculated assuming humidity is 50%. By setting humidity input to "ON", an arbitrary value can be input for humidity.

 Humidity input: see Section 12.2 "Setting of Atmospheric Correction Value".

Operating procedure	Operation	Display
1 After pressing the {MENU} key, press the {F4} (P↓) key twice to get the menu on page 3.	{MENU} {F4} {F4}	MENU 3/4 F1: ILLUMINATION F2: PARAMETERS 1 F3: PARAMETERS 2 P↓
2 Press the {F2} key.	{F2}	PARAMETERS 1 1/4 F1: MINIMUM READING F2: AUTO POWER OFF F3: TILT P↓
3 Press the {F4} key.	{F4}	PARAMETERS 1 2/4 F1: ERROR CORRECTION F2: RS-232C F3: SELECT COM P↓
4 Press the {F4} key.	{F4}	PARAMETERS 1 3/4 F1: BLUETOOTH F2: HUMID. INPUT F3: NP-TRK. MODE P↓
5 Press the {F2} key. Current setting is displayed.	{F2}	HUMID. INPUT [ON] F1: ON F2: OFF ENTER
6 Press the {F1} (ON) key or {F2} (OFF) key, and press the {F4} (ENTER) key.	{F1} or {F2} {F4}	

6.4.9 NP-TRK MODE Setting

Set the distance mode here for performing tracking measurement, setting "Non-prism" as target type.

"ROAD" is the dedicated measuring mode to sight road surface etc. obliquely to obtain rough measurement values. Normally use "STANDARD".

Operating procedure	Operation	Display
1 After pressing the {MENU} key, press the {F4} (P↓) key twice to get the menu on page 3.	{MENU} {F4} {F4}	MENU 3/4 F1: ILLUMINATION F2: PARAMETERS 1 F3: PARAMETERS 2 P↓
2 Press the {F2} key.	{F2}	PARAMETERS 1 1/4 F1: MINIMUM READING F2: AUTO POWER OFF F3: TILT P↓
3 Press the {F4} key.	{F4}	PARAMETERS 1 2/4 F1: ERROR CORRECTION F2: RS-232C F3: SELECT COM P↓
4 Press the {F4} key.	{F4}	PARAMETERS 1 3/4 F1: BLUETOOTH F2: HUMID. INPUT F3: NP-TRK. MODE P↓
5 Press the {F3} key. Current setting is displayed.	{F3}	NP-TRK. MODE [F1: STANDARD] F2: ROAD ENTER
6 Press the {F1} (Standard) key or {F2} (Road) key, and press the {F4} (ENTER) key.	{F1} or {F2} {F4}	

Note

- The circled icon is displayed when "ROAD" being set in "NP-TRK.MODE" and performing NP-TRK measurement.

V : 90°10'20"	
HR: 120°30'40"	
SD* 131.678 m	
MEAS MODE NP/P P1↓	

6.4.10 EDM ECO. MODE Setting

Working duration will be longer by controlling and saving power to the EDM device.



- Time required to start distance measurement will be longer than usual when "EDM ECO. MODE" is set to "ON".

Operating procedure	Operation	Display
1 After pressing the {MENU} key, press the {F4} (P↓) key twice to get the menu on page 3.	{MENU} {F4} {F4}	MENU 3/4 F1: ILLUMINATION F2: PARAMETERS 1 F3: PARAMETERS 2 P↓
2 Press the {F2} key.	{F2}	PARAMETERS 1 1/4 F1: MINIMUM READING F2: AUTO POWER OFF F3: TILT P↓
3 Press the {F4} key.	{F4}	PARAMETERS 1 2/4 F1: ERROR CORRECTION F2: RS-232C F3: SELECT COM P↓
4 Press the {F4} key.	{F4}	PARAMETERS 1 3/4 F1: BLUETOOTH F2: HUMID. INPUT F3: NP-TRK. MODE P↓
5 Press the {F4} key.	{F4}	PARAMETERS 1 4/4 F2: EDM ECO. MODE F3: VOLUME P↓
6 Press the {F1} key. Current setting is displayed.	{F1}	EDM ECO. MODE [F1: ON] F2: OFF ENTER
7 Press the {F1} (ON) key or {F2} (OFF) key, and press the {F4} (ENTER) key.	{F1} or {F2} {F4}	

6.4.11 Volume Setting

Set beep volume.

Volume (0 to 5, 0: beep is OFF) can also be set.

Operating procedure	Operation	Display
1 After pressing the {MENU} key, press the {F4} (P↓) key three times to get the menu on page 4.	{MENU} {F4} {F4} {F4}	<div style="border: 1px solid black; padding: 5px;"> PARAMETERS 1 4/4 F2 : EDM ECO . MODE F3 : VOLUME P↓ </div>
2 Press the {F2} key. The data previously set is shown.	{F2}	<div style="border: 1px solid black; padding: 5px;"> VOLUME LEVEL : 0 ↓ ↑ --- ENTER </div>
3 Press the {F1} (↓) key or {F2} (↑) key, and press the {F4} (ENTER) key.	{F1} or {F2} {F4}	
<ul style="list-style-type: none"> ● To return to previous mode, press the {ESC} key. 		

6.5 Setting Contrast of Display

Setting level for contrast of display (LCD)

Operating procedure	Operation	Display
1 After pressing the {MENU} key, press the {F4} (P↓) key three times to get the menu on page 4.	{MENU} {F4} {F4} {F4}	MENU 4 / 4 F1:ADJUSTMENT MODE F2:CONTRAST ADJ. F3:STATUS SCREEN P↓
2 Press the {F2} key.	{F2}	CONTRAST ADJUSTMENT LEVEL: 4 ↓ ↑ --- ENTER
3 Press the {F1} (↓) key or {F2} (↑) key, and press the {F4} (ENTER) key.	{F1} or {F2} {F4}	

6.6 Displaying Instrument Information

Serial number and software version of your instrument are displayed.

Operating procedure	Operation	Display
1 After pressing the {MENU} key, press the {F4} (P↓) key three times to get the menu on page 4.	{MENU} {F4} {F4} {F4}	MENU 4 / 4 F1:ADJUSTMENT MODE F2:CONTRAST ADJ. F3:STATUS SCREEN P↓
2 Press the {F3} key.	{F3}	GM-62 S/N XXX123456 VER. X.XXXX_XX X.XX_XX P↓
3 Press the {F4} key. Functions on your instrument are displayed.	{F4}	BUILD Internal Pt. :50000 Bluetooth P↓
4 Press the {ESC} key.	{ESC}	

6.7 Road

● Road menu operation

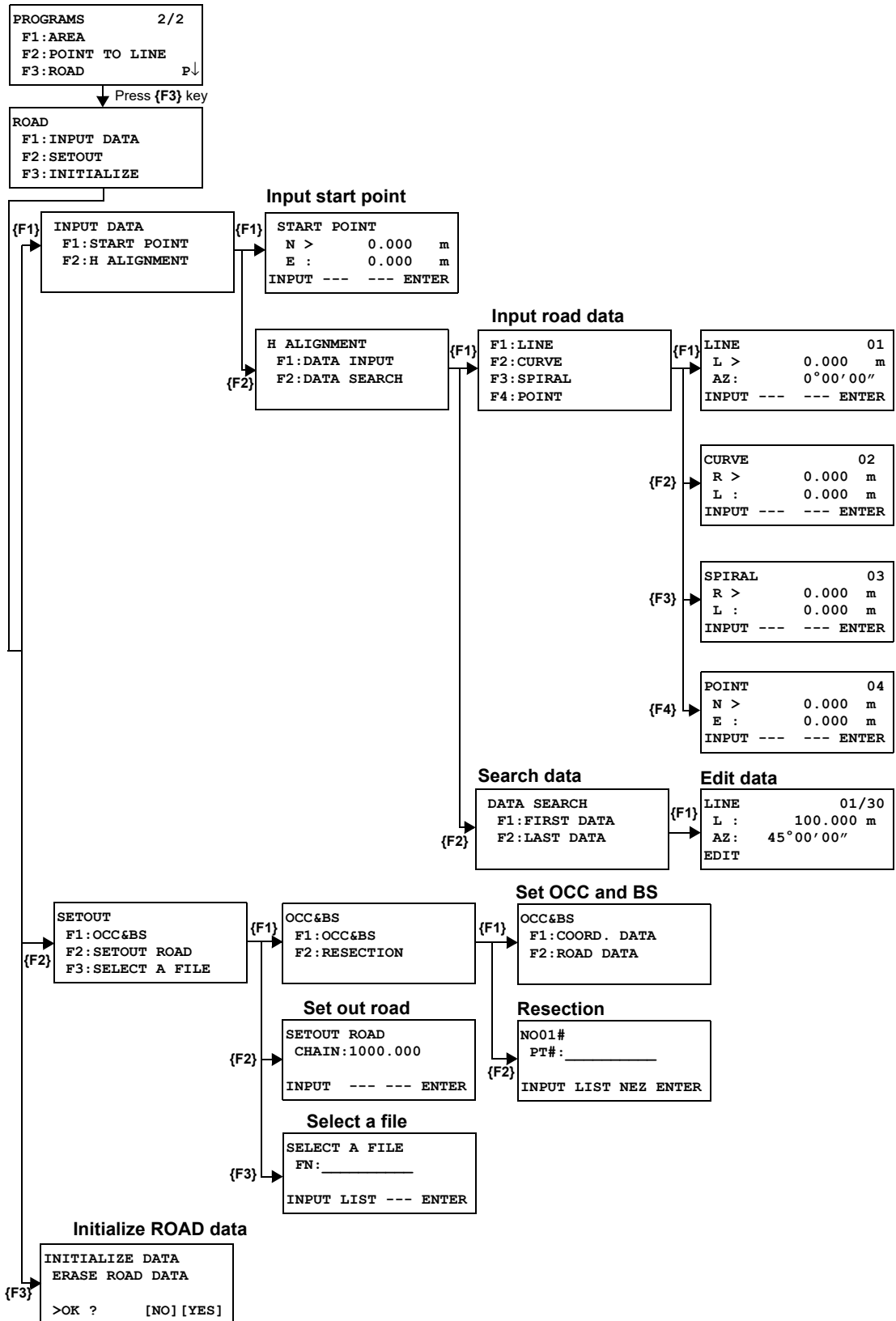

6.7.1 Inputting Start Point

To input the start point, carry out the following operating procedure.

Operating procedure	Operation	Display
1 After pressing the {MENU} key, press the {F4} (P↓), {F2}, {F4} key to get the programs menu on page 2/2.	{MENU} {F4} {F2} {F4}	<pre>PROGRAMS 2/2 F1:AREA F2:POINT TO LINE F3:ROAD P↓</pre>
2 Press the {F3}, {F1}, {F1} key. (Refer to "Input start point" on page 6-30.)	{F3} {F1} {F1}	<pre>START POINT N = 0.000 m E : 0.000 m --- --- [CLR] [ENT]</pre>
3 Input coord N, E. 4 Press the {ENT} key.	Input coord {ENT}	<pre>START POINT CHAIN = 0.000 m INTERVAL:100.000 m --- --- [CLR] [ENT]</pre>
5 Input value data CHAIN, INTERVAL. 6 Press the {ENT} key.	Input data {ENT}	<pre><SET!></pre> <pre>INPUT DATA F1:START POINT F2:H ALIGNMENT</pre>
<ul style="list-style-type: none"> For [ROAD], in addition to the "Start Point" and "Road Data" input files, other files necessary for the calculations are created. Consequently, if the free area of the memory reaches 10% or less, a "MEMORY POOR" warning message is displayed. (In this case, the instrument can still be operated.) CHAIN and INTERVAL input range $-50,000 \text{ m} \leq \text{CHAIN} \leq 500,000 \text{ m}$ $0 \text{ m} < \text{INTERVAL} \leq 5,000 \text{ m}$ 		

6.7.2 Inputting Road Data

[ROAD] is made up of four types of components: LINE, CURVE, SPIRAL and POINT.
To input the required components, carry out the following operating procedure.

Operating procedure	Operation	Display
1 After pressing the {MENU} key, press the {F4} (P↓), {F2} , {F4} key to get the programs menu on page 2/2.	{MENU} {F4} {F2} {F4}	<pre>PROGRAMS 2/2 F1 : AREA F2 : POINT TO LINE F3 : ROAD P↓</pre>
2 Press the {F3} , {F1} , {F2} , {F1} key. (☞ Refer to "Input road data" on page 6-30.)	{F3} {F1} {F2} {F1}	<pre>F1 : LINE F2 : CURVE F3 : SPIRAL F4 : POINT</pre>
<ul style="list-style-type: none"> The amount of input data varies depending on the type of data, up to a maximum of 30. (In the case of POINT input only, the maximum is 9 points including end point.) An error may occur when entering a combination of POINT and other components if the amount of data entered exceeds the maximum amount allowed for internal calculations. If this happens, please reduce the amount of input data. 		

- Input LINE data

Operating procedure	Operation	Display
1 To input LINE data, press the {F1} key. *1)	{F1}	<pre>F1 : LINE F2 : CURVE F3 : SPIRAL F4 : POINT</pre>
2 Input LENGTH. 3 Press the {ENT} key.	Input LENGTH {ENT}	<pre>LINE 01 L = 0.000 m AZ: 0°00'00" --- --- [CLR] [ENT]</pre>
4 Input AZIMUTH. 5 Press the {ENT} key.	Input AZIMUTH {ENT}	<pre>LINE 01 L : 100.000 m AZ= 0°00'00" --- --- [CLR] [ENT]</pre> <p style="text-align: center;">⋮</p> <pre><SET!></pre>
<p>*1) The number at the top right of the screen shows the amount of data currently entered.</p>		

- Input CURVE data

Operating procedure	Operation	Display
<p>1 To input CURVE data, press the {F2} key. *1)</p> <p>2 Input RADIUS.</p> <p>3 Press the {ENT} key.</p> <p>4 Input LENGTH.</p> <p>5 Press the {ENT} key.</p> <p>6 Select TURN (direction of turn): RIGHT or LEFT.</p> <p>7 Press the {ENT} key.</p>	<p>{F2}</p> <p>Input RADIUS {ENT}</p> <p>Input LENGTH {ENT}</p> <p>Select {F1} (LEFT) or {F2} (RIGHT) {ENT}</p>	<div style="border: 1px solid black; padding: 5px; margin-bottom: 5px;"> F1 : LINE F2 : CURVE F3 : SPIRAL F4 : POINT </div> <div style="border: 1px solid black; padding: 5px; margin-bottom: 5px;"> CURVE 02 R = 0.000 m L : 0.000 m --- --- [CLR] [ENT] </div> <div style="border: 1px solid black; padding: 5px; margin-bottom: 5px;"> CURVE 02 R : 100.000 m L = 0.000 m --- --- [CLR] [ENT] </div> <div style="text-align: center; margin-bottom: 5px;"> </div> <div style="border: 1px solid black; padding: 5px; margin-bottom: 5px;"> CURVE 02 TURN > RIGHT LEFT RIGHT --- ENTER </div> <div style="border: 1px solid black; padding: 5px; text-align: center; margin-bottom: 5px;"> <SET!> </div>
<p>*1) CURVE cannot be input as the first data.</p>		

- Input SPIRAL data

Operating procedure	Operation	Display
<p>1 To input SPIRAL data, press the {F3} key. *1)</p> <p>2 Input RADIUS.</p> <p>3 Press the {ENT} key.</p> <p>4 Input LENGTH.</p> <p>5 Press the {ENT} key.</p> <p>6 Select TURN (direction of turn): RIGHT or LEFT.</p> <p>7 Press the {ENT} key.</p> <p>8 Select DIR (direction): IN (entrance) or OUT (exit).</p> <p>9 Press the {ENT} key.</p>	<p>{F3}</p> <p>Input RADIUS {ENT}</p> <p>Input LENGTH {ENT}</p> <p>Select {F1} (LEFT) or {F2} (RIGHT) {ENT}</p> <p>Select {F1} (IN) or {F2} (OUT) {ENT}</p>	<div style="border: 1px solid black; padding: 5px; margin-bottom: 5px;"> F1: LINE F2: CURVE F3: SPIRAL F4: POINT </div> <div style="border: 1px solid black; padding: 5px; margin-bottom: 5px;"> SPIRAL 03 R = 0.000 m L : 0.000 m --- --- [CLR] [ENT] </div> <div style="border: 1px solid black; padding: 5px; margin-bottom: 5px;"> SPIRAL 03 R : 100.000 m L = 0.000 m --- --- [CLR] [ENT] </div> <div style="text-align: center; margin-bottom: 5px;"> </div> <div style="border: 1px solid black; padding: 5px; margin-bottom: 5px;"> SPIRAL 03 TURN > RIGHT DIR : IN LEFT RIGHT --- ENTER </div> <div style="border: 1px solid black; padding: 5px; margin-bottom: 5px;"> SPIRAL 03 TURN : LEFT DIR > IN IN OUT --- ENTER </div> <div style="border: 1px solid black; padding: 5px; text-align: center;"> <SET!> </div>
<p>*1) SPIRAL cannot be input as the first data.</p>		

- Input POINT data

Operating procedure	Operation	Display
1 To input POINT data, press the {F4} key.	{F4}	<div style="border: 1px solid black; padding: 5px;"> F1 : LINE F2 : CURVE F3 : SPIRAL F4 : POINT </div> <div style="border: 1px solid black; padding: 5px;"> POINT 04 N = 0.000 m E : 0.000 m --- --- [CLR] [ENT] </div>
2 Input N coord. 3 Press the {ENT} key.	Input N coord {ENT}	<div style="border: 1px solid black; padding: 5px;"> POINT 04 N : 100.000 m E = 0.000 m --- --- [CLR] [ENT] </div>
4 Input E coord. 5 Press the {ENT} key.	Input E coord {ENT}	<div style="border: 1px solid black; padding: 5px;"> R > 0.000 m A1: 0.000 A2: 0.000 INPUT --- SKIP ENTER </div>
6 Input RADIUS. *1) 7 Press the {ENT} key.	Input RADIUS {ENT}	<div style="border: 1px solid black; padding: 5px;"> R : 100.000 m A1> 0.000 A2: 0.000 INPUT --- SKIP ENTER </div>
8 Input parameter A1. *1) 9 Press the {ENT} key.	Input parameter A1 {ENT}	<div style="border: 1px solid black; padding: 5px;"> R : 100.000 m A1: 80.000 A2> 0.000 INPUT --- SKIP ENTER </div>
10 Input parameter A2. *1) 11 Press the {ENT} key.	Input parameter A2 {ENT}	<div style="border: 1px solid black; padding: 5px;"> <p style="text-align: center;">⋮</p> </div> <div style="border: 1px solid black; padding: 5px; text-align: center; margin-top: 10px;"> <SET!> </div>
<p>*1) If the data input is not required, press the [SKIP] key.</p> <ul style="list-style-type: none"> ● When inputting POINT data, if the next data is not POINT data, ROAD is calculated as a straight line irrespective of the values for RADIUS, A1 and A2. 		

6.7.3 Searching Data

To search for input data, carry out the following operating procedure.

Operating procedure	Operation	Display
1 After pressing the {MENU} key, press the {F4} (P↓), {F2} , {F4} key to get the programs menu on page 2/2.	{MENU} {F4} {F2} {F4}	<pre>PROGRAMS 2/2 F1: AREA F2: POINT TO LINE F3: ROAD P↓</pre>
2 Press the {F3} , {F1} , {F2} , {F2} key. (☞ Refer to "Search data" on page 6-30.)	{F3} {F1} {F2} {F2}	<pre>DATA SEARCH F1: FIRST DATA F2: LAST DATA</pre>
3 To search from the first data, select {F1} (FIRST DATA).	{F1}	<pre>LINE 01/30 L : 100.000 m AZ: 45°00'00" EDIT ↓</pre>
4 To switch to different data, press the [↓] or [↑] key.	[↓] or [↑]	⋮
		<pre>SPIRAL 30/30 R : 200.000 m L : 100.000 m EDIT ↓</pre>

6.7.4 Editing Data

To edit input data, carry out the following operating procedure.

Operating procedure	Operation	Display
1 In DATA SEARCH, press the {F1} key.	{F1}	<pre>LINE 01/30 L : 100.000 m AZ: 45°00'00" EDIT ↓</pre>
2 Edit the data.	Edit data	<pre>LINE 01 L = 100.000 m AZ: 45°00'00" --- --- [CLR] [ENT]</pre>

6.7.5 Setting OCC and BS

To set the Occupied Point and Backsight Point, carry out the following operating procedure.

Operating procedure	Operation	Display
<p>1 After pressing the {MENU} key, press the {F4} (P↓), {F2}, {F4} key to get the programs menu on page 2/2.</p>	<p>{MENU} {F4} {F2} {F4}</p>	<pre>PROGRAMS 2/2 F1:AREA F2:POINT TO LINE F3:ROAD P↓</pre>
<p>2 Press the {F3}, {F2}, {F1} key. (☞ Refer to "Set OCC and BS" on page 6-30.)</p>	<p>{F3} {F2} {F1}</p>	<pre>OCC&BS F1:OCC&BS F2:RESECTION</pre>
<p>3 Press the {F1} key. *1)</p>	<p>{F1}</p>	<pre>OCC&BS F1:COORD. DATA F2:ROAD DATA</pre>
<p>4 To input OCC. PT, press the {F1} (COORD. DATA) or {F2} (ROAD DATA) key.</p> <p>COORD. DATA: Choose the data from Coord Data and set the Occupied Point.</p> <p>ROAD DATA: Create the data from Road Data and set the Occupied Point.</p> <p>(Example: ROAD DATA)</p>	<p>{F2}</p>	<pre>OCC. PT CHAIN= --- --- [CLR] [ENT]</pre>
<p>5 Input OCC. PT, press the {ENT} key.</p>	<p>Input OCC. PT {ENT}</p>	<pre>CHAIN:1000.000 >CENTER LEFT RIGHT --- ENTER</pre>
<p>6 Press the {ENT} key.</p> <p>LEFT or RIGHT: Use the offset point. CENTER: Use the center point.</p> <p>(Example: CENTER)</p>	<p>{ENT}</p>	<pre>CHAIN:1000.000 N : 0.000 m E : 0.000 m >OK ? [YES] [NO]</pre>
<p>7 Press the {F3} (YES) key.</p>	<p>{F3}</p>	<pre>BACKSIGHT CHAIN= --- --- [CLR] [ENT]</pre>
<p>8 Input the backsight.</p>	<p>Input Backsight</p>	
<p>9 Press the {ENT} key.</p>	<p>{ENT}</p>	<pre>CHAIN: 0.000 >CENTER LEFT RIGHT --- ENTER</pre>

10 Collimate the backsight.	Collimate Backsight	BACKSIGHT H (B) = 45° 00' 00" >Sight? [YES] [NO]
11 Press the {F3} (YES) key.	{F3}	<p style="text-align: center;"><SET!></p>
<p>*1) When setting the Occupied Point and Backsight Point using Resection method, select {F2} (RESECTION).  For details of the Resection method, refer to Section 8.3.2 "Resection Method".</p>		

6.7.6 Stake-out Road

To setout the road, carry out the following operating procedure.

Operating procedure	Operation	Display
<p>1 After pressing the {MENU} key, press the {F4} (P↓), {F2}, {F4} key to get the programs menu on page 2/2.</p>	<p>{MENU} {F4} {F2} {F4}</p>	<pre>PROGRAMS 2/2 F1:AREA F2:POINT TO LINE F3:ROAD P↓</pre>
<p>2 Press the {F3}, {F2}, {F2} key. (Refer to "Set out road" on page 6-30.)</p>	<p>{F3} {F2} {F2}</p>	<pre>SETOUT ROAD CHAIN= --- --- [CLR] [ENT]</pre>
<p>3 Input data.</p>	<p>Input data</p>	<pre>SETOUT ROAD CHAIN=1200 --- --- [CLR] [ENT]</pre>
<p>4 Press the {ENT} key.</p>	<p>{ENT}</p>	<pre>CHAIN:1200 > CENTER LEFT RIGHT --- ENTER</pre>
<p>5 Select offset. (Example: RIGHT) Press the {F2} key. *1)</p>	<p>{F2}</p>	<pre>CHAIN:1200 : RIGHT = m --- --- [CLR] [ENT]</pre>
<p>6 Input the offset value.</p>	<p>Input offset value</p>	
<p>7 Press the {ENT} key. The setout point coordinates are displayed.</p>	<p>{ENT}</p>	<pre>CHAIN:1200 N : 0.000 m E : 0.000 m >OK ? [YES] [NO]</pre>
<p>8 Press the {F3} (YES) key. The distance to the setout point and the backsight are displayed. HR: Calculated horizontal angle of the layout point HD: Calculated horizontal distance from the instrument to the layout point</p>	<p>{F3}</p>	<pre>CALCULATED HR= 60°00'00" HD= 100.000 m ANGLE DIST --- ---</pre>
<p>9 Press the {F1} (ANG) key. CHAIN: Layout point HR: Measured (Actual) horizontal angle. dHR: Horizontal angle to be turned to the layout point = Actual horizontal angle - Calculated horizontal angle. Correct direction when dHR = 0°00'00"</p>	<p>{F1}</p>	<pre>CHAIN:1200 HR: 60°00'00" dHR: 0°00'00" DIST --- NEZ ---</pre>
<p>10 Press the {F1} (DIST) key. HD: Measuring (Actual) horizontal distance dHD: Horizontal distance to be turned to the layout point = Actual horizontal distance - Calculated horizontal distance.</p>	<p>{F1}</p>	<pre>HD* 100.000 m dHD: 0.000 m MODE NEZ NP/P NEXT</pre>

11 Press the {F3} (NEZ) key. The coordinate data is shown.	{F3}	<table border="1"> <tr> <td>N *</td> <td>70.000 m</td> </tr> <tr> <td>E :</td> <td>50.000 m</td> </tr> <tr> <td>MODE</td> <td>ANG NP/P NEXT</td> </tr> </table>	N *	70.000 m	E :	50.000 m	MODE	ANG NP/P NEXT
N *	70.000 m							
E :	50.000 m							
MODE	ANG NP/P NEXT							
12 Press the {F4} (NEXT) key to set next layout point.	{F4}							
*1) If not selecting offset, press the {ENT} key.								

6.7.7 Selecting a File

To set the coordinates to be used for the Occupied Point and Backsight Point, carry out the following operating procedure.

Operating procedure	Operation	Display								
1 After pressing the {MENU} key, press the {F4} (P↓), {F2} , {F4} key to get the programs menu on page 2/2.	{MENU} {F4} {F2} {F4}	<table border="1"> <tr> <td>PROGRAMS</td> <td>2/2</td> </tr> <tr> <td>F1: AREA</td> <td></td> </tr> <tr> <td>F2: POINT TO LINE</td> <td></td> </tr> <tr> <td>F3: ROAD</td> <td>P↓</td> </tr> </table>	PROGRAMS	2/2	F1: AREA		F2: POINT TO LINE		F3: ROAD	P↓
PROGRAMS	2/2									
F1: AREA										
F2: POINT TO LINE										
F3: ROAD	P↓									
2 Press the {F3} , {F2} key. (☞ Refer to "Select a file" on page 6-30.)	{F3} {F2}	<table border="1"> <tr> <td>SETOUT</td> </tr> <tr> <td>F1: OCC&BS</td> </tr> <tr> <td>F2: SETOUT ROAD</td> </tr> <tr> <td>F3: SELECT A FILE</td> </tr> </table>	SETOUT	F1: OCC&BS	F2: SETOUT ROAD	F3: SELECT A FILE				
SETOUT										
F1: OCC&BS										
F2: SETOUT ROAD										
F3: SELECT A FILE										
3 Press the {F3} key.	{F3}	<table border="1"> <tr> <td>SELECT A FILE</td> </tr> <tr> <td>FN: _____</td> </tr> <tr> <td>INPUT LIST --- ENTER</td> </tr> </table>	SELECT A FILE	FN: _____	INPUT LIST --- ENTER					
SELECT A FILE										
FN: _____										
INPUT LIST --- ENTER										
4 Enter the name of the file being used (or select it from the list).	Select a file									
5 Press the {ENT} key.	{ENT}									

6.7.8 Initializing ROAD data

To initialize the data, carry out the following operating procedure.

Operating procedure	Operation	Display								
1 After pressing the {MENU} key, press the {F4} (P↓), {F2} , {F4} key to get the programs menu on page 2/2.	{MENU} {F4} {F2} {F4}	<table border="1"> <tr> <td>PROGRAMS</td> <td>2/2</td> </tr> <tr> <td>F1: AREA</td> <td></td> </tr> <tr> <td>F2: POINT TO LINE</td> <td></td> </tr> <tr> <td>F3: ROAD</td> <td>P↓</td> </tr> </table>	PROGRAMS	2/2	F1: AREA		F2: POINT TO LINE		F3: ROAD	P↓
PROGRAMS	2/2									
F1: AREA										
F2: POINT TO LINE										
F3: ROAD	P↓									
2 Press the {F3} , {F3} key. (☞ Refer to "Initialize ROAD data" on page 6-30.)	{F3} {F3}	<table border="1"> <tr> <td>INITIALIZE DATA</td> </tr> <tr> <td>ERASE ROAD DATA</td> </tr> <tr> <td>>OK ? [NO] [YES]</td> </tr> </table>	INITIALIZE DATA	ERASE ROAD DATA	>OK ? [NO] [YES]					
INITIALIZE DATA										
ERASE ROAD DATA										
>OK ? [NO] [YES]										
3 When the {F4} (YES) key is pressed, all ROAD DATA with the exception of the coordinate data file is erased. Press the {F4} key.	{F4}									

7 DATA COLLECTION

The GM is able to store the measured data into the internal memory.
The internal memory is shared by the measured data files and the coordinate data files.

- **Measured data**
The collected data is memorized into a files.
- **The number of measurement points**
(In case not using the internal memory in layout mode)

MAX. 50,000 points

Because the internal memory covers both data collection mode and layout mode, the number of measurement points will be decreased when the layout mode is used.

 For the internal memory, refer to Chapter 9 "MEMORY MANAGER MODE".



- When turning off the power, ensure that you are in the main menu screen or main angle measurement mode.
This ensures completion of the memory access process and avoids possible damage to the stored data.
- It is recommended for safety to charge the battery beforehand and prepare fully charged spare batteries.

● Data collect menu operation

By pressing the {MENU} key, the instrument will be in MENU 1/3 mode.
 Press the {F2} (DATA COLLECT) key, the menu of data collect 1/2 will be shown.

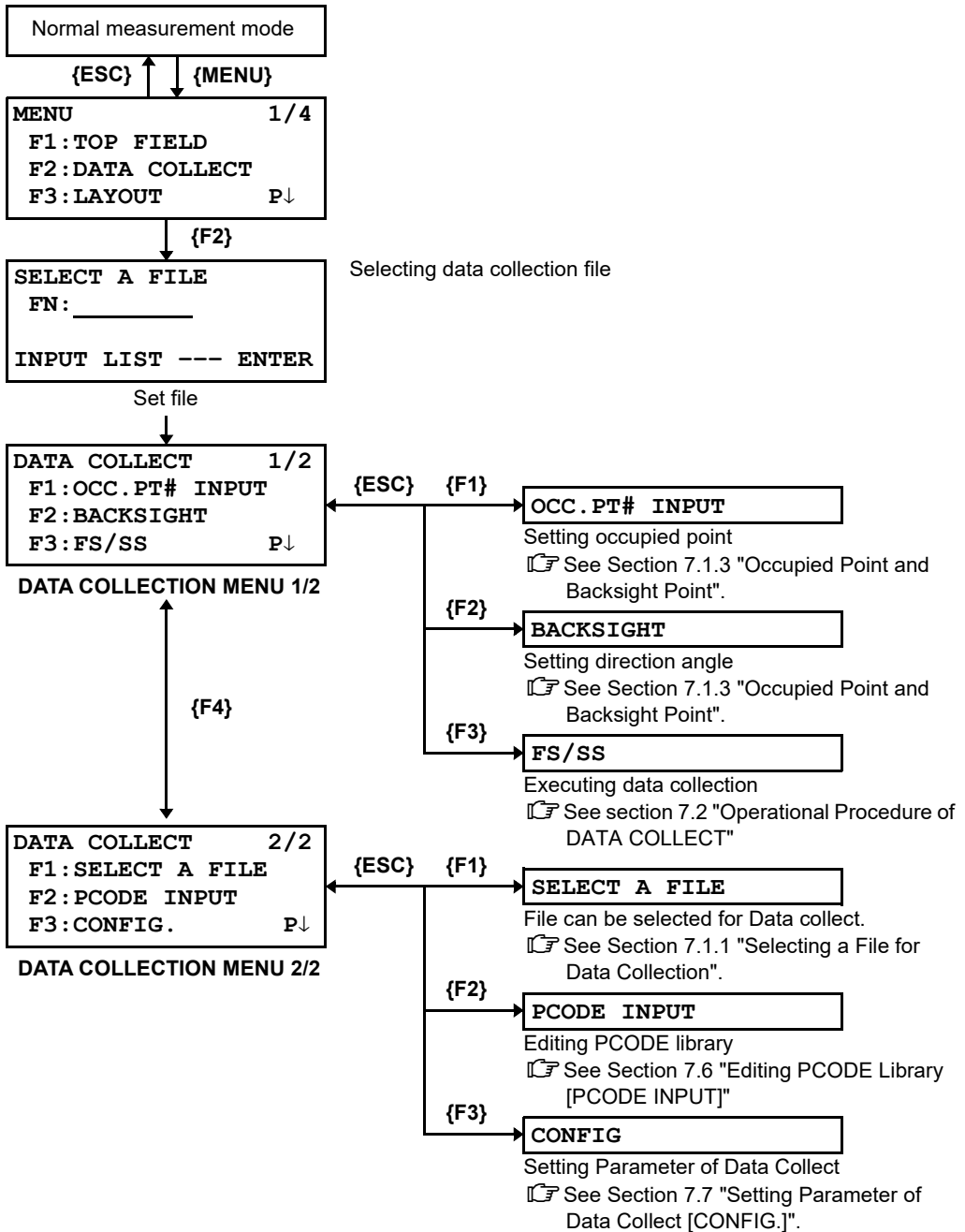

7.1 Preparation

7.1.1 Selecting a File for Data Collection

A file used by data collection mode must be selected at first.

Select a file before beginning data collection mode because selection screen of a file is displayed. And a selection from data collection menu is possible in the mode.

Operating procedure	Operation	Display
<p>1 Press {F2} (DATA COLLECT) key from menu 1/4.</p> <p>2 Press {F2} (LIST) key to display the list of file. *1)</p> <p>3 Scroll file list by pressing {▼} or {▲} key and select a file to use. *2),3)</p> <p>4 Press {F4} (ENTER) key. The file will be set and data collect 1/2 menu will be shown.</p>	<p>{F2}</p> <p>{F2}</p> <p>{▼} or {▲}</p> <p>{F4}</p>	<pre> MENU 1/4 F1:TOP FIELD F2:DATA COLLECT F3:LAYOUT P↓ </pre>
		<pre> SELECT A FILE FN: _____ INPUT LIST --- ENTER </pre>
		<pre> AMIDATA /M0123 →*HILDATA /M0345 TOPDATA /M0789 --- SRCH --- ENTER </pre>
		<pre> TOPDATA /M0789 →RAPDATA /M0564 SATDATA /M0456 --- SRCH --- ENTER </pre>
		<pre> DATA COLLECT 1/2 F1:OCC.PT# INPUT F2:BACKSIGHT F3:FS/SS P↓ </pre>
<p>*1) If you want to make a new file or input file name directly, press {F1} (INPUT) key and enter a file name.</p> <p>*2) When a file has been selected already, "*" mark is indicated on left of current file name.</p> <p>*3) Data in a file shown with arrow can be searched by pressing {F2} (SRCH) key.</p>		
<p>Note</p> <ul style="list-style-type: none"> It is possible to select a file from DATA COLLECT 2/2 menu in the same way. 		<pre> DATA COLLECT 2/2 F1:SELECT A FILE F2:PCODE INPUT F3:CONFIG. P↓ </pre>

7.1.2 Selecting a Coordinate File for Data Collection

When coordinate data in a coordinate data file are used for occupied point or backsight point, select a coordinate file from the data collect menu 2/2 beforehand.

Operating procedure	Operation	Display
<p>1 Press the {F1} (SELECT A FILE) key from DATA COLLECT menu 2/2.</p>	<p>{F1}</p>	<pre>DATA COLLECT 2/2 F1:SELECT A FILE F2:PCODE INPUT F3:CONFIG. P↓</pre>
<p>2 Press the {F2} (COORD.DATA) key.</p>		<p>{F2}</p>
<p>3 Select a coordinate file in the same manner as Section 7.1.1 "Selecting a File for Data Collection".</p>		<pre>SELECT A FILE FN: _____ INPUT LIST --- ENTER</pre>

7.1.3 Occupied Point and Backsight Point

The occupied point and direction angle in the data collect mode are linked with the occupied point and direction angle in normal coordinate measurement. It is possible to set or change the occupied point and direction angle from the data collect mode.

Occupied point can be set by two setting methods as follow.

- Setting from the coordinate data stored in the internal memory.
- Direct key input.

The following three setting methods for backsight point can be selected.

- Setting from the coordinate data stored in the internal memory.
- Direct key input of coordinate data.
- Direct key input of setting angle.

 See 9.4 "Coordinate Data Direct Key Input" and 9.7.2 "Loading Data" for how to store coordinate into the internal memory.

● **Example for setting the occupied point:**

In case of setting occupied point from the coordinate data stored in the internal memory.

Operating procedure	Operation	Display
1 Press the {F1} (OCC.PT# INPUT) key from the data collect menu 1/2. The previous data is shown.	{F1}	PT# →PT-01 ID : INS.HT: 0.000 m INPUT SRCH REC OCNEZ
2 Press the {F4} (OCNEZ) key.	{F4}	OCC.PT PT#:PT-01 INPUT LIST NEZ ENTER
3 Press the {F1} (INPUT) key and enter PT#.*1) Press the {F4} (ENT) key.	{F1} Enter PT# {F4}	N: 0.000m E: 0.000m Z: 0.000m >OK? [YES] [NO]
4 Press the {F3} (YES) key.	{F3}	PT# →PT-11 ID : INS.HT: 0.000 m INPUT SRCH REC OCNEZ
5 Enter ID, INS.HT in the same way. *2),3)	Enter ID, INS.HT	PT# :PT-11 ID : INS.HT→ 1.335 m INPUT SRCH REC OCNEZ >REC ? [YES] [NO]
6 Press {F3} (REC) key.	{F3}	
7 Press {F3} (YES) key. The display returns to the data collect menu 1/2.	{F3}	DATA COLLECT 1/2 F1:OCC.PT# INPUT F2:BACKSIGHT F3:FS/SS P↓

*1)  Refer to Section 2.4 "How to Enter Alphanumeric Characters".

*2) ID can be input by inputting a register number linked with PCODE Library.
To show the list of PCODE library, press the **{F2}** (SRCH) key.



*3) Press the **{F3}** (REC) key when you do not input the INS.HT.

 **Note**

- The data recorded in data collect is PT#, ID and INS.HT.
- If point is not found in internal memory "PT# DOES NOT EXIST" is displayed.



● **Example for setting the direction angle:**

The following is to memorize the data of the backsight after setting the backsight point from point number.

Operating procedure	Operation	Display
<p>1 Press the {F2} (BACKSIGHT) key from the data collect menu 1/2. The previous data is shown.</p>	{F2}	<pre>BS# → PCODE : R.HT : 0.000 m INPUT 0SET MEAS BS</pre>
<p>2 Press the {F4} (BS) key. *1)</p>	{F4}	<pre>BACKSIGHT PT# : INPUT LIST NE/AZ ENT</pre>
<p>3 Press the {F1} (INPUT) key and enter PT#. *2)</p>	{F1} Enter PT#	<pre>N: 0.000m E: 0.000m Z: 0.000m >OK? [YES] [NO]</pre>
<p>4 Press the {F3} (YES) key. Enter PCODE,R.HT in the same way. *3),4)</p>	{F3}	<pre>BS# →PT-22 PCODE : R.HT : 0.000 m INPUT 0SET MEAS BS</pre>
<p>5 Press the {F3} (MEAS) key.</p>	{F3}	<pre>BS# →PT-22 PCODE : R.HT : 0.000 m *VH SD NEZ NP/P</pre>
<p>6 Collimate back sight point. Select one of the measuring mode and press the soft key. EXAMPLE: {F2} (Slope Distance) key. Horizontal circle is set to calculated direction angle. Measuring starts. Measuring result is memorized and the display returns to the data collect menu 1/2.</p>	Collimate BS {F2}	<pre>V : 90°00'00" HR: 0°00'00" SD*[n] <<< m > Measuring...</pre> <p style="text-align: center;">↓</p> <pre>DATA COLLECT 1/2 F1:OCC.PT# INPUT F2:BACKSIGHT F3:FS/SS P↓</pre>
<p>*1) Pressing each time the {F3} key, the input method changes as Coordinate value, Angle, Coordinate point name alternatively.</p> <p>*2)  Refer to Chapter 2.4 "How to Enter Alphanumeric Characters".</p> <p>*3) PCODE can be input by inputting a register number linked with PCODE Library. To show the list of PCODE library, press the {F2} (SRCH) key.</p> <p>*4) Data collect sequence can be set to [MEAS→EDIT].  Refer to Section 7.7 "Setting Parameter of Data Collect [CONFIG.]".</p> <p>Note</p> <ul style="list-style-type: none"> If point is not found in internal memory " PT# DOES NOT EXIST" is displayed. 		

7.2 Operational Procedure of DATA COLLECT

Operating procedure	Operation	Display
		<pre>DATA COLLECT 1/2 F1:OCC.PT# INPUT F2:BACKSIGHT F3:FS/SS P↓</pre>
<p>1 Press the {F3} (FS/SS) key from the data collect menu 1/2. The previous data is shown.</p>	{F3}	<pre>PT# → PCODE : R.HT : 0.000 m INPUT SRCH MEAS ALL</pre>
<p>2 Press the {F1} (INPUT) key and enter PT#. Press the {F4} (ENT) key. *1)</p>	{F1} Enter PT# {F4}	<pre>PT# =PT-01 PCODE : R.HT : 0.000 m [ALP] [SPC] [CLR] [ENT]</pre>
		<pre>PT# :PT-01 PCODE → R.HT : 0.000 m INPUT SRCH MEAS ALL</pre>
<p>3 Enter PCODE, R.HT in the same way. *2),3)</p>	{F1} Enter PCODE {F4} {F1}	<pre>PT# →PT-01 PCODE :TOPCON R.HT : 1.200 m INPUT SRCH MEAS ALL</pre>
<p>4 Press the {F3} (MEAS) key.</p>	{F1} EnterR.HT {F4} {F3}	<pre>VH *SD NEZ P1↓</pre>
<p>5 Collimate the target point.</p>	Collimate	
<p>6 Press one of the {F1} to {F3} key. *4) Example: {F2} (SD) key. Measuring starts.</p> <p>The measuring data is memorized and the display changes to the next point. *5) PT# is automatically incremented.</p>	{F2}	<pre>V : 90°10'20" HR: 120°30'40" SD*[n] < m > Measuring... < complete ></pre> <p style="text-align: center;">↓</p> <pre>PT# →PT-02 PCODE :TOPCON R.HT : 1.200 m INPUT SRCH MEAS ALL</pre>
<p>7 Enter the next point data and collimate the next point.</p>	Collimate	
<p>8 Press {F4} (ALL) key. Measuring starts in the same measuring mode of the previous point. Data is recorded.</p> <p>Continue the measuring in the same way. To finish the mode, press {ESC} key.</p>	{F4}	<pre>V : 90°10'20" HR: 120°30'40" SD*[n] < m > Measuring... < complete ></pre> <p style="text-align: center;">↓</p> <pre>PT# →PT-03 PCODE :TOPCON R.HT : 1.200 m INPUT SRCH MEAS ALL</pre>

- *1)  Refer to Section 2.4 "How to Enter Alphanumeric Characters".
- *2) PCODE can be input by inputting a register number linked with PCODE Library.
To show the list of PCODE library, press the {F2} (SRCH) key.
- *3) Data collect sequence can be set to [MEAS→EDIT].  See to Section 7.7 "Setting Parameter of Data Collect [CONFIG.]".
- *4) The mark "*" indicates the previous measuring mode.
- *5) You can confirm the measured data as follows.  Refer to Section 7.7 "Setting Parameter of Data Collect [CONFIG.]".

V	:	90°10'20"
HR	:	120°30'40"
SD	:	98.765 m
> OK ?		[YES] [NO]

7.2.1 Searching the recorded data

While executing the DATA COLLECT mode, you can search the recorded data.

Operating procedure	Operation	Display																
<p>1 While executing the DATA COLLECT mode, press {F2} (SRCH) key. *1)</p> <p>The using file name will appear on the top of the right side of the display.</p> <p>2 Select one of three search methods by pressing {F1} to {F3} key. *2)</p>	<p>{F2}</p> <p>{F1} to {F3}</p>	<table border="1"> <tr> <td>PT#</td> <td>→ PT-02</td> </tr> <tr> <td>PCODE</td> <td>:</td> </tr> <tr> <td>R.HT</td> <td>: 1.200 m</td> </tr> <tr> <td>INPUT SRCH MEAS ALL</td> <td></td> </tr> </table> <table border="1"> <tr> <td>SEARCH</td> <td>[TOPCON]</td> </tr> <tr> <td>F1</td> <td>: FIRST DATA</td> </tr> <tr> <td>F2</td> <td>: LAST DATA</td> </tr> <tr> <td>F3</td> <td>: PT# DATA</td> </tr> </table>	PT#	→ PT-02	PCODE	:	R.HT	: 1.200 m	INPUT SRCH MEAS ALL		SEARCH	[TOPCON]	F1	: FIRST DATA	F2	: LAST DATA	F3	: PT# DATA
PT#	→ PT-02																	
PCODE	:																	
R.HT	: 1.200 m																	
INPUT SRCH MEAS ALL																		
SEARCH	[TOPCON]																	
F1	: FIRST DATA																	
F2	: LAST DATA																	
F3	: PT# DATA																	
<p>*1) It is possible to see the PCODE list when the arrow is located beside PCODE or ID. *2) The operation is same as the "SEARCH" in the MEMORY MANAGER mode.  For more information, refer to Section 9.2 "Searching Data".</p>																		

7.2.2 Entering PCODE / ID using PCODE Library

While executing the DATA COLLECT mode, you can enter PCODE /ID from PCODE Library.

Operating procedure	Operation	Display																								
<p>1 Move the arrow to the PCODE or ID in the DATA COLLECT mode, press the {F1} (INPUT) key.</p> <p>2 Enter a register number linked with PCODE library and press the {F4} (ENT) key. (Example) Register number, 32 = TOPCON</p>	<p>{F1}</p> <p>Enter No {F4}</p>	<table border="1"> <tr> <td>PT#</td> <td>: PT-02</td> </tr> <tr> <td>PCODE</td> <td>→</td> </tr> <tr> <td>R.HT</td> <td>: 1.200 m</td> </tr> <tr> <td>INPUT SRCH MEAS ALL</td> <td></td> </tr> </table> <table border="1"> <tr> <td>PT#</td> <td>: PT-02</td> </tr> <tr> <td>PCODE</td> <td>=32</td> </tr> <tr> <td>R.HT</td> <td>: 1.200 m</td> </tr> <tr> <td>[ALP] [SPC] [CLR] [ENT]</td> <td></td> </tr> </table> <table border="1"> <tr> <td>PT#</td> <td>: PT-02</td> </tr> <tr> <td>PCODE</td> <td>: TOPCON</td> </tr> <tr> <td>R.HT</td> <td>→ 1.200 m</td> </tr> <tr> <td>INPUT SRCH MEAS ALL</td> <td></td> </tr> </table>	PT#	: PT-02	PCODE	→	R.HT	: 1.200 m	INPUT SRCH MEAS ALL		PT#	: PT-02	PCODE	=32	R.HT	: 1.200 m	[ALP] [SPC] [CLR] [ENT]		PT#	: PT-02	PCODE	: TOPCON	R.HT	→ 1.200 m	INPUT SRCH MEAS ALL	
PT#	: PT-02																									
PCODE	→																									
R.HT	: 1.200 m																									
INPUT SRCH MEAS ALL																										
PT#	: PT-02																									
PCODE	=32																									
R.HT	: 1.200 m																									
[ALP] [SPC] [CLR] [ENT]																										
PT#	: PT-02																									
PCODE	: TOPCON																									
R.HT	→ 1.200 m																									
INPUT SRCH MEAS ALL																										

7.2.3 Entering PCODE / ID from the list of PCODE

You can also enter PCODE / ID from the list of PCODE.

Operating procedure	Operation	Display
<p>1 Move the arrow to the PCODE or ID in the DATA COLLECT mode, press the {F2} (SRCH) key.</p> <p>2 By pressing the following keys, the register number will increase or decrease. {▲} or {▼}: Increasing or Decreasing one by one {▶} or {◀}: By ten Increasing or Decreasing. *1)</p> <p>3 Press the {F4} (ENTER) key.</p>	<p>{F2}</p> <p>{▲} or {▼} {▶} or {◀}</p> <p>{F4}</p>	<pre>PT# : PT-02 PCODE → R.HT : 1.200 m INPUT SRCH MEAS ALL</pre> <pre>→001:PCODE01 002:PCODE02 EDIT --- CLR ENTER</pre> <pre>031:PCODE31 →032:TOPCON 033:HILTOP EDIT --- CLR ENTER</pre> <pre>PT# : PT-02 PCODE : TOPCON R.HT → 1.200 m INPUT SRCH MEAS ALL</pre>
<p>*1) To edit the PCODE library, press the {F1} (EDIT) key. To delete the PCODE registered with shown an arrow, press the {F3} (CLR) key.</p> <p>Note</p> <ul style="list-style-type: none"> PCODE can be edited in DATA COLLECT menu 2/2 or MEMORY MANAGER menu 2/3. 		

7.3 Data Collect Offset Measurement mode

This mode is useful when it is difficult to set up the prism directly, for example at the center of a tree. Data Collect. Offset Measurement has two measuring methods.

- Angle offset measurement
- Distance offset measurement
- Plane offset measurement
- Column offset measurement

7.3.1 Angle Offset Measurement

Place the prism at the same horizontal distance from the instrument as that of point A0 to measure.

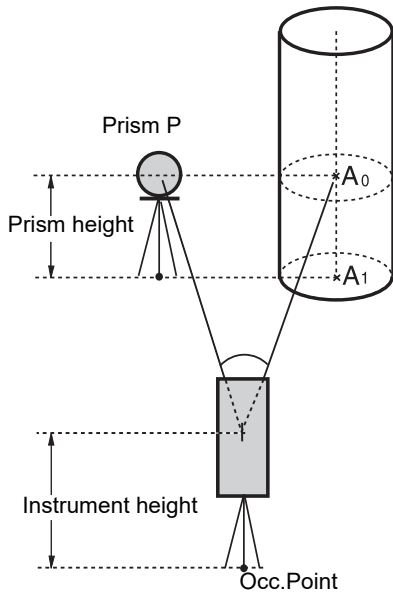





When measuring coordinates of ground point A1: Set the instrument height / prism height.

When measuring coordinates of point A0: Set the instrument height only. (Set the prism height to 0).

When sighting to A₀, you can select one of two ways. One is to fix vertical angle to the prism position even up down the telescope position, and the other is to gear vertical angle to the up down of telescope movement. In case following the vertical angle to the movement of telescope, SD (Slope Distance) and VD (Vertical Distance) will be changed according to the movement of telescope.

To set this option, refer to Chapter 17 "SELECTING MODE".

Operating procedure	Operation	Display
1 Press the {F3} (MEAS) key and press the {F4} key to get to the next soft key page.	{F3} {F4}	PT# →PT-11 PCODE : TOPCON R.HT : 1.200 m INPUT SRCH MEAS ALL
		PT# →PT-11 PCODE : TOPCON R.HT : 1.200 m VH *SD NEZ P1↓ OFFSET PTL NP/P P2↓
2 Press the {F1} (OFFSET) key.	{F1}	OFFSET 1/2 F1: ANG. OFFSET F2: DIST. OFFSET F3: PLANE OFFSET P↓
3 Press the {F1} (ANG.OFFSET) key.	{F1}	OFFSET-MEASUREMENT HR: 120°30'40" HD: m MEAS --- NP/P ---
4 Collimate the prism.	Collimate P	

<p>5 Press the {F1} (MEAS) key. Continuous measuring starts.</p>	<p>{F1}</p>	<pre> OFFSET-MEASUREMENT HR: 120°30'40" HD*[n] < m >measuring ... </pre>
<p>6 Collimate point A0 using the horizontal motion clamp and horizontal tangent screw.</p>	<p>Collimate A0</p>	<pre> OFFSET-MEASUREMENT HR: 120°30'40" SD* 12.345 m >OK? [YES] [NO] </pre>
<p>7 Show the horizontal distance of point A0.</p>	<p>{}</p>	<pre> OFFSET-MEASUREMENT HR: 123°30'40" SD: 12.345 m >OK? [YES] [NO] </pre>
<p>8 Show the relative elevation of point A0.</p> <ul style="list-style-type: none"> Each time pressing {} key, horizontal distance, relative elevation and slope distance are shown in sequence. 	<p>{}</p>	<pre> OFFSET-MEASUREMENT HR: 123°30'40" HD: 6.543 m >OK? [YES] [NO] </pre>
<p>9 Show N coordinate of point A0 or A1.</p> <ul style="list-style-type: none"> Each time pressing {} key, N,E and Z coordinate are shown in sequence. 	<p>{}</p>	<pre> OFFSET-MEASUREMENT HR: 123°30'40" VD: 0.843 m >OK? [YES] [NO] </pre>
<p>10 Press the {F3} (YES) key.</p>	<p>{F3}</p>	<pre> OFFSET-MEASUREMENT HR: 123°30'40" N : -12.345 m >OK? [YES] [NO] </pre>
<p>The data is recorded and the next measuring point is displayed.</p>		<pre> PT# →PT-12 PCODE :TOPCON R.HT : 1.200 m INPUT SRCH MEAS ALL </pre>

7.3.2 Distance Offset Measurement

The measurement of a place apart from a prism is possible by inputting offset horizontal distance of front and back / right and left.

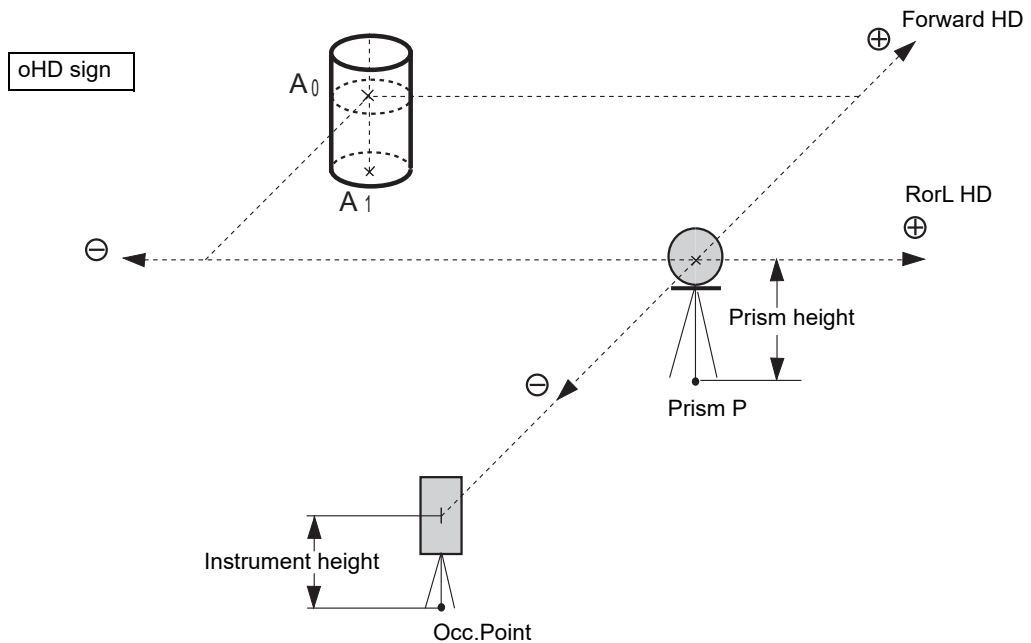

When measuring coordinates of ground point A₁: Set the instrument height / prism height.

When measuring coordinates of point A₀: Set the instrument height only.
(Set the prism height to 0).

Operating procedure	Operation	Display
1 Press the {F3} (MEAS) key and press the {F4} key to get to the next soft key page.	{F3} {F4}	PT# →PT-11 PCODE :TOPCON R.HT : 1.200 m INPUT SRCH MEAS ALL
		PT# →PT-11 PCODE :TOPCON R.HT : 1.200 m VH *SD NEZ P1↓ OFFSET PTL NP/P P2↓
2 Press the {F1} (OFFSET) key.	{F1}	OFFSET 1/2 F1:ANG. OFFSET F2:DIST. OFFSET F3:PLANE OFFSET P↓
3 Press the {F2} (DIST.OFFSET) key.	{F2}	DISTANCE OFFSET INPUT RorL HD oHD=0.000 m --- --- [CLR] [ENT]
4 Enter Right and Left direction offset value.*1)	Enter HD {F4}	DISTANCE OFFSET INPUT FORWARD HD oHD=0.000 m --- --- [CLR] [ENT]

<p>5 Enter Forward direction offset value. *1)</p>	<p>Enter HD {F4}</p>	<pre>PT# :PT-11 PCODE : TOPCON R.HT : 1.200 m --- *SD NEZ NP/P</pre>
<p>6 Collimate the prism.</p>	<p>Collimate P</p>	<pre>N*[n] <<< m E : m Z : m >measuring ... >Calculating...</pre>
<p>7 Press the {F2} or {F3} key. Example:{F3} (NEZ) key Measuring starts.</p>	<p>{F3}</p>	<p style="text-align: center;">↓</p> <pre>PT# →PT-12 PCODE :TOPCON R.HT : 1.200 m INPUT SRCH MEAS ALL</pre>
<p>The data is recorded and the next measuring point is displayed.</p>		
<p>*1) To skip entering, press the {F3} (SKP) key.</p>		



7.3.3 Plane Offset Measurement

Measuring will be taken for the place where direct measuring can not be done, for example distance or coordinate measuring for a edge of a plane.

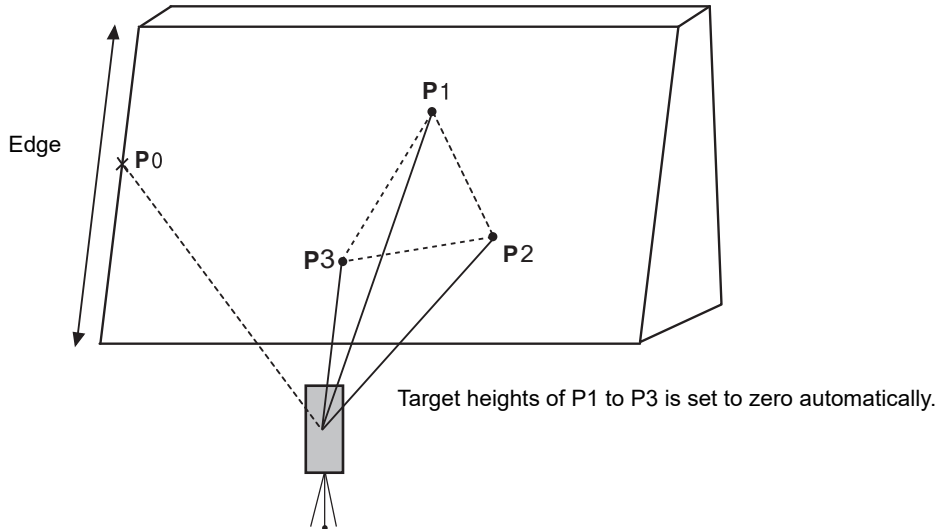
Three random points (P1, P2, P3) on a plane will be measured at first in the plane offset measurement to determine the measured plane. Collimate the measuring point (P0) then the instrument calculates and displays coordinate and distance value of cross point between collimation axis and of the plane.



Operating procedure	Operation	Display
<p>1 Press the {F3} (MEAS) key and press the {F4} key to get to the next soft key page.</p> <p>2 Press the {F1} (OFFSET) key.</p> <p>3 Press the {F3} (PLANE OFFSET) key.</p> <p>4 Collimate prism P1, and press the {F1} (MEAS) key. Measuring will start. After measuring, the display will show the second point measurement.</p>	<p>{F3} {F4}</p>	<pre>PT# →PT-11 PCODE :TOPCON R.HT : 1.200 m INPUT SRCH MEAS ALL</pre>
		<pre>PT# →PT-11 PCODE :TOPCON R.HT : 1.200 m VH *SD NEZ P1↓ OFFSET PTL NP/P P2↓</pre>
	<pre>OFFSET 1/2 F1:ANG. OFFSET F2:DIST. OFFSET F3:PLANE OFFSET P↓</pre>	
	<pre>PLANE N001#: SD: m MEAS --- NP/P ---</pre>	
	<p>Collimate P1 {F1}</p>	<pre>PLANE N001#: SD* [n] << m >Measuring...</pre> <p style="text-align: center;">↓</p>

<p>5 Measure the second and third points in the same way. *1)</p>	<p>Collimate P2 {F1}</p>	<pre> PLANE N002#: SD: m MEAS --- NP/P --- </pre>	
<p>The display changes to PT# input in the plane offset measurement. Input point number if necessary.</p>	<p>Collimate P3 {F1}</p>	<pre> PLANE N003#: SD: m MEAS --- NP/P --- </pre>	
<p>6 Press the {F4} (MEAS) key. The instrument calculates and displays coordinate and distance value of cross point between collimation axis and of the plane. *2)</p>	<p>{F4}</p>	<pre> PLANE PT# → PT-11 PCODE : TOPCON INPUT SRCH --- MEAS </pre>	
<p>7 Collimate the edge (P0) of the plane. *3), 4)</p>	<p>Collimate P0</p>	<pre> HR: 80°30'40" HD: 54.321 m VD: 10.000 m >OK? [YES] [NO] </pre>	
<p>8 To show the slope distance (SD), press the {} key.</p> <ul style="list-style-type: none"> Each time pressing the {} key, horizontal distance, relative elevation and slope distance are shown in sequence. To show coordinate value of point P0, press the {} key. 	<p>Collimate P0</p>	<pre> HR: 75°30'40" HD: 54.600 m VD: -0.487 m >OK? [YES] [NO] </pre>	
<p>9 Press the {F3} (YES) key. Next offset point number will be displayed.</p>	<p>{F3}</p>	<pre> V : 90°30'40" HR: 75°30'40" SD: 54.602 m >OK? [YES] [NO] </pre>	
<p>10 To escape the measuring, press the {ESC} key. The display returns to the next point number in data collect mode.</p>	<p>{ESC}</p>	<pre> PLANE PT# → PT-12 PCODE : TOPCON INPUT SRCH --- MEAS </pre>	
<p>*1) In case the calculation of plane was not successful by the measured three points, error displays. Start measuring over again from the first point. *2) Data display is the mode beforehand of offset measurement mode. *3) Error will be displayed when collimated to the direction which does not cross with the determined plane. *4) The reflector height of the target point P0 is set to zero automatically</p>			<pre> PT# → PT-12 PCODE : TOPCON R.HT : 1.200 m INPUT SRCH MEAS ALL </pre>

7.3.4 Column Offset Measurement

If it is possible to measure circumscription point (P1) of column directly, the distance to the center of the column (P0), coordinate and direction angle can be calculated by measured circumscription points (P2) and (P3).

The direction angle of the center of the column is 1/2 of total direction angle of circumscription points (P2) and (P3).

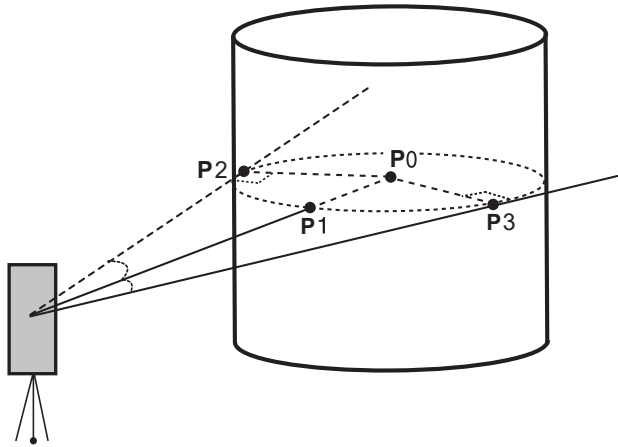

Example: Non-prism measurement

Operating procedure	Operation	Display
<p>1 Press the {F3} (MEAS) key and press the {F4} key to get to the next soft key page.</p> <p>2 Press the {F1} (OFSET) key.</p> <p>3 Press the {F4} (P1↓) key.</p> <p>4 Press the {F1} (COLUMN OFFSET) key.</p> <p>5 Collimate the center of the column (P1) and press the {F1} (MEAS) key. Measuring will start. After the measurement, angle measuring display of the left side (P2) will be shown.</p>	<p>{F3} {F4}</p> <p>{F1}</p> <p>{F4}</p> <p>{F1}</p> <p>Collimate P1 {F1}</p>	<pre>PT# →PT-11 PCODE :TOPCON N R.HT : 1.200 m INPUT SRCH MEAS ALL</pre>
		<pre>PT# →PT-11 PCODE :TOPCON N R.HT : 1.200 m VH *SD NEZ P1↓ OFFSET PTL NP/P P2↓</pre>
		<pre>OFFSET 1/2 F1:ANG. OFFSET N F2:DIST. OFFSET P F3:PLANE OFFSET P↓</pre>
		<pre>OFFSET 2/2 F1:COLUMN OFFSET N P↓</pre>
		<pre>COLUMN OFFSET Center N HD: m MEAS --- NP/P ---</pre>
<pre>COLUMN OFFSET Center N HD* [n] << m >Measuring...</pre> <p style="text-align: center;">↓</p>		

- 6** Collimate the left side of the column (P2) and press the **{F4}** (SET) key.
After the measurement, angle measuring display of the right side (P3) will be shown.

- 7** Collimate the right side of the column (P3) and press the **{F4}** (SET) key.

The distance between the instrument and center of the column (P0) will be calculated.

To show the relative elevation (VD), press the **{}** key.

Each time pressing the **{}** key, horizontal distance, relative elevation and slope distance are shown in sequence.

To show coordinate of point P0, press the **{}** key.

- 8** Press the **{F3}** (YES) key. The display returns to the next point number in data collect mode.

Collimate
P2
{F4}

```

COLUMN OFFSET
Left                N P
HR: 120° 30' 40"
---  ---  ---  SET

```

Collimate
P3
{F4}

```

COLUMN OFFSET
Right               N P
HR: 180° 30' 40"
---  ---  ---  SET

```

```

COLUMN OFFSET
HR: 150° 30' 40"  N P
HD:      43.321 m
>OK?      [YES] [NO]

```

{}

```

COLUMN OFFSET
HR: 150° 30' 40"  N P
VD:      2.321 m
>OK?      [YES] [NO]

```

{F3}

```

PT#   → PT-12
PCODE : TOPCON      N P
R.HT  : 1.200 m
INPUT SRCH MEAS ALL

```

7.4 NEZ Auto Calculation

As measured data is collected, coordinates are calculated and stored for traverse or topo collection. Automatic making out function of coordinate data sets up in CONFIG of data collect.

 Refer to Section 7.7 "Setting Parameter of Data Collect [CONFIG]."

As a default, coordinate data calculated will be saved in a file of the same name as the measurement data file.

When the coordinate data file of the same name as the measurement data file does not exist, it will be generated automatically.

It is possible to change a file for saving coordinate data in the DATA COLLECT Menu 2/2 (F1:SELECT A FILE).

To calculate a coordinate data, it is necessary to add a point number in Data Collect execution.

When a coordinate data of the same point number exist already, it can be replaced with the new data by confirming display.

Note

- Coordinates will be calculated using the grid factor.
 To set the grid factor, see Section 6.2 "Setting the GRID FACTOR".

7.5 Point to Line Measurement

In this mode, a offsetting point from a certain determined line can be measured.

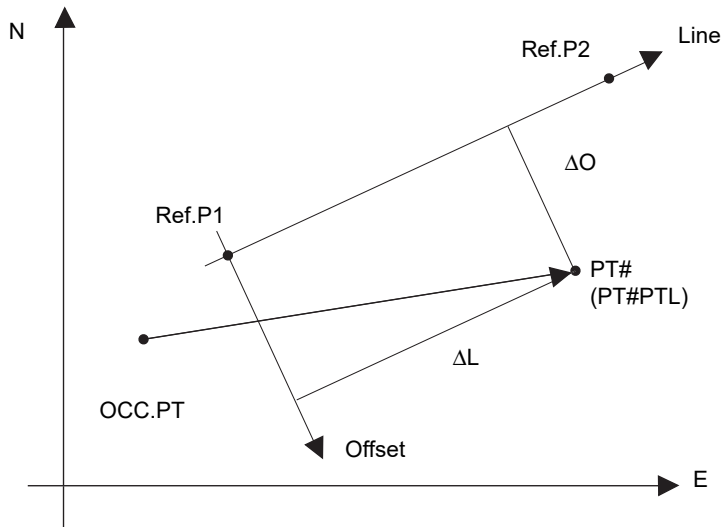

7.5.1 To change to the point to line measurement

Operating procedure	Operation	Display
<p>1 Press the {F3} (MEAS) key and press the {F4} key to get to the next soft key page.</p> <p>2 Press the {F2} (PTL) key.</p> <p>3 Press the {F1} (ON) key and press the {F4} (ENTER) key. The input screen of a reference point 1 will appear.</p> <p>4 Enter the point 1 data and press the {F4} (Enter). The input screen of a reference point 2 will appear.</p> <p>5 Enter the point 2 data and press the {F4} (Enter). The screen will return to data collect measurement. If the PTL measurement mode is available, 'PTL' will appear next to PT#.</p>	<p>{F3}</p> <p>{F4}</p>	<p>PT# →PT-01 PCODE :TOPCON R.HT : 1.500 m INPUT SRCH MEAS ALL</p>
		<p>PT# →PT-01 PCODE :TOPCON R.HT : 1.500 m VH *SD NEZ P1↓ OFSET PTL NP/P P2↓</p>
	<p>{F2}</p>	<p>POINT TO LINE MODE [F1:ON] F2:OFF ENTER</p>
	<p>{F4}</p>	<p>REF. POINT 1 PT#: _____ INPUT LIST --- ENTER</p>
	<p>Input data {F4}</p>	<p>REF. POINT 2 PT#: _____ INPUT LIST --- ENTER</p>
<p>Input data {F4}</p>	<p>PT#PTL→PT-01 PCODE :TOPCON R.HT : 1.500 m INPUT SRCH MEAS ALL</p>	

7.5.2 Executing a point to line measurement

Operating procedure	Operation	Display
<p>Conduct data measurement according to the same procedure as with ordinary FS/SS (ALL can also be selected). However, when you conduct observation in the angle mode, PTL data will not be displayed (only the raw data will be recorded, upon which the operation will end).</p> <p>1 Press the {F3} (MEAS) key.</p> <p>2 Press the {F2} (SD) key. If the PTL mode is on, then, after the coordinate data is calculated, the PTL data will be displayed regardless of the coordinate check setting, etc.</p> <p>3 PTL measurement data will display. Confirm the data and press {F3} (YES) key. The recorded data are measured data and coordinate data generated at the same time as a PTL data.</p>	<p>{F3}</p> <p>{F2}</p> <p>{F3}</p>	<pre>PT#PTL→PT-01 PCODE :TOPCON R.HT : 1.500 m INPUT SRCH MEAS ALL</pre> <pre>PT#PTL→PT-01 PCODE :TOPCON R.HT : 1.500 m VH *SD NEZ P1↓</pre> <pre>V : 90°10'20" HR: 120°30'40" SD* < m > Measuring...</pre> <pre>L: 44.789 m O: 33.456 m E: 2.321 m >REC? [YES] [NO]</pre> <pre>PT#PTL→PT-02 PCODE :TOPCON R.HT : 1.500 m INPUT SRCH MEAS ALL</pre>
<ul style="list-style-type: none"> In the PTL measurement mode, NEZ Auto Calculation will be turned on compulsorily and the coordinate data will be stored into a coordinate file. 		

7.6 Editing PCODE Library [PCODE INPUT]

PCODE data can be entered into PCODE Library in this mode.

A PCODE is linked with a number of 1 to 50.

PCODE can be also edited in MEMORY MANAGER menu 2/3 in the same way.

Operating procedure	Operation	Display
<p>1 Press the {F2} (PCODE INPUT) key from Data Collect menu 2/2.</p>	<p>{F2}</p>	<pre>DATA COLLECT 2/2 F1:SELECT A FILE F2:PCODE INPUT F3:CONFIG. P↓</pre>
<p>2 By pressing the following keys, the list will increase or decrease.</p> <p>{▲} or {▼}: Increasing or Decreasing one by one.</p> <p>{▶} or {◀}: By ten Increasing or Decreasing.</p>	<p>{▲} or {▼} {▶} or {◀}</p>	<pre>→001:TOPCON 002:TOKYO EDIT --- CLR ---</pre>
<p>3 Press the {F1} (EDIT) key.</p>	<p>{F1}</p>	<pre>011:URAH →012=<u>AMIDAT</u> 013:HILLTO [ALP] [SPC] [CLR] [ENT]</pre>
<p>4 Enter PCODE and press the {F4} (ENT) key. *1)</p>	<p>Enter PCODE {F4}</p>	<pre>011:URAH →012:AMISUN 013:HILLTO EDIT --- CLR ---</pre>
<p>*1)  Refer to Section 2.4 "How to Enter Alphanumeric Characters".</p>		

7.7 Setting Parameter of Data Collect [CONFIG.]

In this mode, the following settings of data collect mode are possible.

● Setting Items

Menu	Selecting Item	Contents
F1:DIST MODE	FINE / CRS(1) / CRS(10)	Select Fine /Coarse(1) /Coarse(10) mode in distance measurement mode. The unit to be displayed is as follows. Fine mode: 1 mm (0.1 mm) Coarse (1) mode: 1 mm Coarse (10) mode: 10 mm
F2:HD/SD	HD/SD	Select the distance measurement mode Horizontal Distance or Slope distance.
F3:MEAS. SEQ.	N-TIMES / SINGLE / REPEAT	Select to set measurement mode for distance measurement.
F1:DATA CONFIRM	YES/NO	It is possible to confirm the result of measuring data before the data is recorded.
F2:COLLECT SEQ.	[EDIT→MEAS] / [MEAS→EDIT]	Select the procedure of data collection. [EDIT→MEAS]: Measurement is carried out after entering other data. [MEAS→EDIT]: Measurement is carried out before entering other data.
F3:NEZ AUTO. CALC	ON/OFF	It is possible to calculate coordinate value of data collected and store it into coordinate data file in every data collection.

● How to Set Items

Example Setting: DATA CONFIRM: YES

Operating procedure	Operation	Display
<p>1 Press the {F3} (CONFIG.) key from the data collect menu 2/2. The CONFIG menu 1/2 is shown.</p> <p>2 Press the {F4} (P↓) key to display the CONFIG menu 2/2.</p> <p>3 Press the {F1} (DATA CONFIRM) key. [] indicates the current setting.</p> <p>4 Press the {F1} (YES) key.</p> <p>5 Press the {F4} (ENTER) key.</p>	<p>{F3}</p> <p>{F4}</p> <p>{F1}</p> <p>{F1}</p> <p>{F4}</p>	<pre> DATA COLLECT 2/2 F1:SELECT A FILE F2:PCODE INPUT F3:CONFIG. P↓ </pre>
		<pre> CONFIG. 1/2 F1:DIST MODE F2:HD/SD F3:MEAS. SEQ. P↓ </pre>
		<pre> CONFIG. 2/2 F1:DATA CONFIRM F2:COLLECT SEQ. F3:NEZ AUTO.CALC P↓ </pre>
		<pre> DATA CONFIRM F1: YES [F2:NO] ENTER </pre>
		<pre> DATA CONFIRM [F1: YES] F2:NO ENTER </pre>

8 LAYOUT

LAYOUT mode has two functions which are setting of layout points and setting new points using coordinate data in the internal memory.

Also, if the coordinate data is not stored in the internal memory, this can be input from keyboard. The coordinate data is loaded from PC to the internal memory via communication port.

- **The coordinate data**

The coordinate data is memorized into a file.

 For the internal memory, refer to Chapter 9 "MEMORY MANAGER MODE".

The GM is able to store the coordinate data into the internal memory.

The internal memory is shared by the measured data and the coordinate data for layout.

Maximum 99 files can be generated.

- **The number of coordinate data**

(In case not using the internal memory in the data collect mode)

MAX. 50,000 points

Because the internal memory covers both data collection mode and layout mode, the number of coordinate data will be decreased when the data collection mode is used.

 **Note**

- When turning off the power, ensure that you are in the main menu screen or main angle measurement mode.
This ensures completion of the memory access process and avoids possible damage to the stored data.
- It is recommended for safety to charge the battery beforehand and prepare fully charged spare batteries.
- When recording new point data, remember to consider the amount of internal memory available.

● **Layout menu operation**

By pressing the {MENU} key, the instrument will be in MENU 1/4 mode.
 Press the {F3} (LAYOUT) key, the menu of layout 1/2 will be shown.

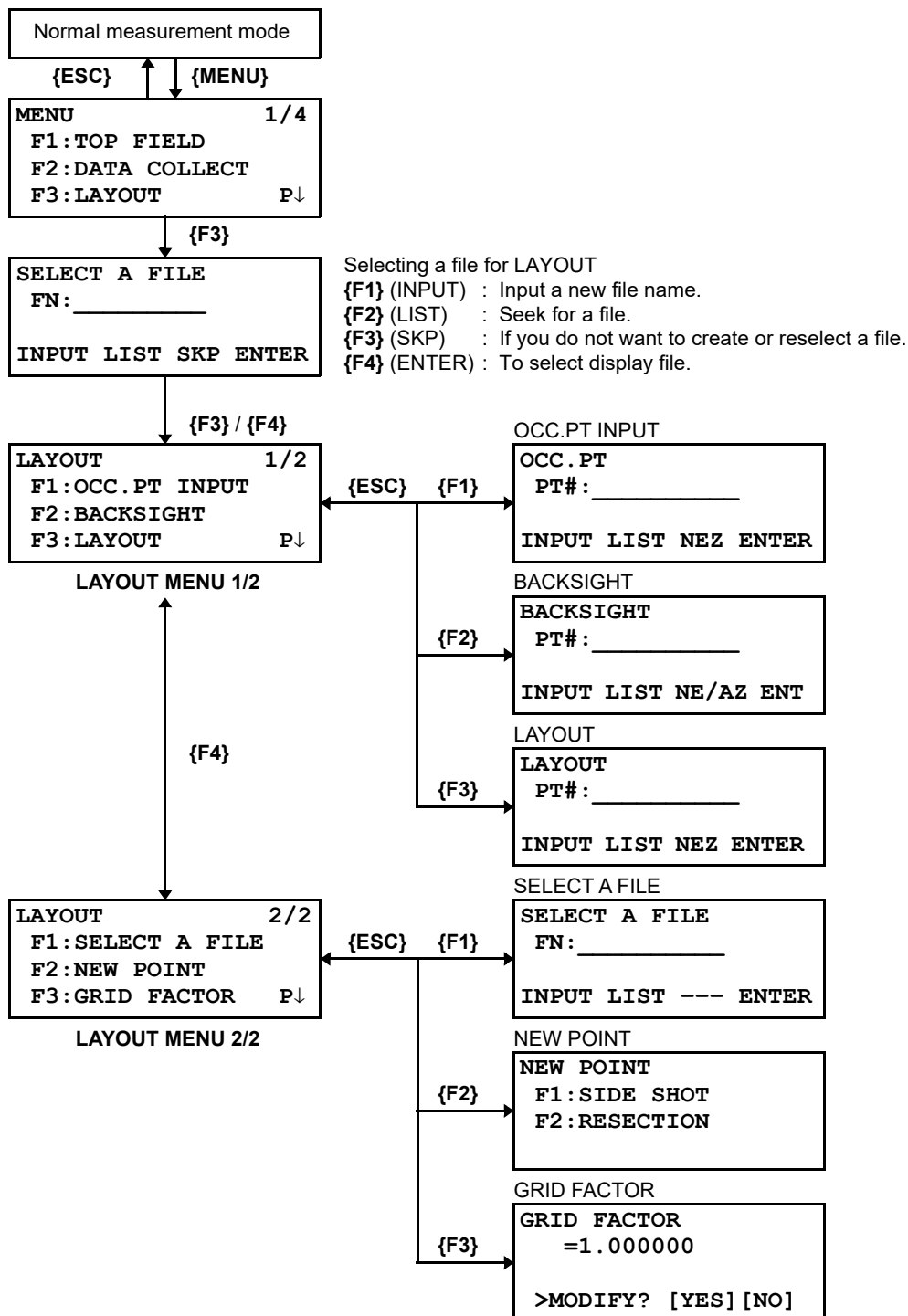

8.1 Preparation

8.1.1 Setting the GRID FACTOR

- **Calculation Formula**

- 1) Elevation Factor

$$\text{Elevation Factor} = \frac{R}{R + \text{ELEV.}}$$

R : The average radius of the earth
 ELEV. : The elevation above mean sea level

- 2) Scale Factor

Scale Factor : Scale Factor at the surveying station

- 3) Grid Factor

Grid Factor = *Elevation Factor* × *Scale Factor*

- **Distance Calculation**

- 1) Grid Distance



$$\text{HDg} = \text{HD} \times \text{Grid Factor}$$

HDg : Grid distance
 HD : Ground distance

- 2) Ground Distance

$$\text{HD} = \frac{\text{HDg}}{\text{Grid Factor}}$$

- **How to Set Grid Factor**

Operating procedure	Operation	Display	
<ol style="list-style-type: none"> 1 Press the {F3} (GRID FACTOR) key from the Layout menu 2/2. 2 Press the {F3} (YES) key. 3 Enter Elevation. *1) Press the {F4} (ENT) key. 4 Enter Scale Factor in the same way. <p>Grid Factor is displayed for 1 to 2 second and display returns to Layout menu 2/2.</p>	{F3}	<pre>LAYOUT 2/2 F1:SELECT A FILE F2:NEW POINT F3:GRID FACTOR P↓</pre>	
		<pre>GRID FACTOR =0.998843 >MODIFY? [YES] [NO]</pre>	
		Enter ELEV. {F4}	<pre>GRID FACTOR ELEV.=1000 m SCALE:0.999000 --- --- [CLR] [ENT]</pre>
			<pre>GRID FACTOR ELEV.:2000 m SCALE=1.001000 --- --- [CLR] [ENT]</pre>
		<pre>GRID FACTOR =1.000686</pre>	
<p>*1)  Refer to Section 2.4 "How to Enter Alphanumeric Characters". Input Range: Elevation : -9,999 to 9,999 meter (-32,805 to 3,2805 ft, ft+in) Scale Factor : 0.990000 to 1.010000  See section 8.1.1 "Setting the GRID FACTOR" for more information.</p>			

8.1.2 Selecting Coordinate Data File

You can execute a Layout from selected coordinate data file, also you can record New point measured data into the selected coordinate data file.

- The only coordinate data file existing can be selected and you can not make a new file in this mode. For more information about File, refer to Chapter 9 "MEMORY MANAGER MODE".
- When LAYOUT MODE is begun, a file can be selected in the same way.

Operating procedure	Operation	Display
<p>1 Press the {F1} (SELECT A FILE) key from the Layout menu 2/2.</p> <p>2 Press the {F2} (LIST) key to display the list of coordinate data file.*1)</p> <p>3 Scroll file list by pressing the {▲} or {▼} key and select a file to use. *2),3)</p> <p>4 Press the {F4} (ENTER) key. The file will be set.</p>	{F1}	LAYOUT 2/2 F1:SELECT A FILE F2:NEW POINT F3:GRID FACTOR P↓
		SELECT A FILE FN: INPUT LIST --- ENTER
	{F2}	COORDDATA /C0123 →*TOKBDATA /C0345 TOPCDATA /C0789 --- SRCH --- ENTER
		*TOKBDATA /C0345 → TOPCDATA /C0789 SATIDATA /C0456 --- SRCH --- ENTER
{F4}	{F4}	LAYOUT 2/2 F1:SELECT A FILE F2:NEW POINT F3:GRID FACTOR P↓
<p>*1) If you want to input file name directly, press the {F1} (INPUT) key and enter a file name.</p> <p>*2) When a file has been selected already, '*' mark is indicated on left of current file name. For the file discrimination mark (*, @, &), refer to Section 9.3 "File Maintenance".</p> <p>*3) Data in a file shown with arrow can be searched by pressing the {F2} (SRCH) key.</p>		

8.1.3 Setting Occupied Point



Occupied point can be set by two setting methods as follow.

- 1) Setting from the coordinate data stored in the internal memory.
- 2) Direct key input of coordinate data.

- Example setting: Setting the occupied point from the internal coordinate data file

Operating procedure	Operation	Display
1 Press the {F1} (OCC.PT INPUT) key from the Layout menu 1/2.	{F1}	<pre>OCC . PT PT# : _____ INPUT LIST NEZ ENTER</pre>
2 Press the {F1} (INPUT) key and enter PT#. *1) Press the {F4} (ENT) key.	{F1} Enter PT# {F4}	<pre>OCC . PT PT#=PT-01 [ALP] [SPC] [CLR] [ENT]</pre>
3 Enter INS.HT in the same way. The display returns to layout menu 1/2.	Enter INS.HT {F4}	<pre>INSTRUMENT HEIGHT INPUT INS . HT= 0.000 m --- --- [CLR] [ENT]</pre> <pre>LAYOUT 1/2 F1:OCC . PT INPUT F2:BACKSIGHT F3:LAYOUT P↓</pre>
*1)  Refer to Section 2.4 "How to Enter Alphanumeric Characters".		

- Example setting: Setting Instrument point coordinates directly

Operating procedure	Operation	Display
1 Press the {F1} (OCC.PT INPUT) key from the Layout menu 1/2.	{F1}	OCC . PT PT# : _____ INPUT LIST NEZ ENTER
2 Press the {F3} (NEZ) key.	{F3}	N→ 0.000 m E: 0.000 m Z: 0.000 m INPUT --- PT# ENTER
3 Press the {F1} (INPUT) key and enter coordinate value. press the {F4} (ENT) key. *1)	{F1} Enter coord. {F4}	COORD . DATA INPUT PT# : _____ INPUT --- --- ENTER
4 Press the {F1} (INPUT) key and enter PT#. Press the {F4} (ENT) key. *2)	{F1} Enter PT# {F4}	INSTRUMENT HEIGHT INPUT INS . HT=0.000 m --- --- [CLR] [ENT]
5 Enter Instrument Height in the same way. The display returns to layout menu 1/2.	Enter INS.HT {F4}	LAYOUT 1/2 F1 : OCC . PT INPUT F2 : BACKSIGHT F3 : LAYOUT P↓
*1)  Refer to Section 2.4 "How to Enter Alphanumeric Characters".		
*2) It is possible to record the coordinate value.  Refer to Chapter 17 "SELECTING MODE".		

8.1.4 Setting Backsight Point



The following three setting methods for Backsight point can be selected.

- 1) Setting from the coordinate data file stored in the internal memory.
- 2) Direct key input of coordinate data.
- 3) Direct key input of setting angle.

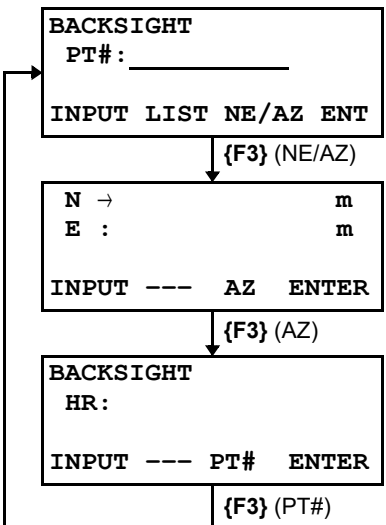
- Example setting: Setting the backsight point from the internal coordinate data file

Operating procedure	Operation	Display
<p>1 Press the {F2} (BACKSIGHT) key from the Layout menu 1/2.</p> <p>2 Press the {F1} (INPUT) key. Enter PT#, press the {F4} (ENT) key. *1)</p> <p>3 Sight the backsight point and press the {F3} (YES) key. The display returns to the layout menu 1/2.</p>	<p>{F2}</p> <p>{F1} Enter PT# {F4}</p> <p>Sight BK {F3}</p>	<div style="border: 1px solid black; padding: 5px; margin-bottom: 5px;"> <p>BACKSIGHT PT#: _____ INPUT LIST NE/AZ ENT</p> </div> <div style="border: 1px solid black; padding: 5px; margin-bottom: 5px;"> <p>BACKSIGHT PT#=BK-01 [ALP] [SPC] [CLR] [ENT]</p> </div> <div style="border: 1px solid black; padding: 5px;"> <p>BACKSIGHT H (B) = 0°00'00" >Sight ? [YES] [NO]</p> </div>
<p>*1)  Refer to 2.4 "How to Enter Alphanumeric Characters".</p> <ul style="list-style-type: none"> ● With each pressing of {F3} key, method of inputting backsight is changed. <div style="text-align: center; margin-top: 20px;">  <pre> graph TD A["BACKSIGHT PT#: _____ INPUT LIST NE/AZ ENT"] -- "{F3} (NE/AZ)" --> B["N → m E : m INPUT --- AZ ENTER"] B -- "{F3} (AZ)" --> C["BACKSIGHT HR: INPUT --- PT# ENTER"] C -- "{F3} (PT#)" --> A </pre> </div>		

- Example setting: Setting the backsight point coordinates directly

Operating procedure	Operation	Display
1 Press the {F2} (BACKSIGHT) key from the Layout menu 1/2. The previous data is shown.	{F2}	<pre> BACKSIGHT PT# : _____ INPUT LIST NE/AZ ENT </pre>
2 Press the {F3} (NE/AZ) key.	{F3}	<pre> N→ m E: m INPUT --- AZ ENTER </pre>
3 Press the {F1} (INPUT) key and enter coordinate value. Press the {F4} (ENT) key. *1), 2)	{F1} Enter coord. {F4}	<pre> BACKSIGHT H (B) = 0°00'00" >Sight ? [YES] [NO] </pre>
4 Sight the backsight point.	Sight BK	
5 Press the {F3} (YES) key. The display returns to the layout menu 1/2.	{F3}	<pre> LAYOUT 1/2 F1:OCC.PT INPUT F2:BACKSIGHT F3:LAYOUT P↓ </pre>
*1)  Refer to Section 2.4 "How to Enter Alphanumeric Characters". *2) It is possible to record the coordinate value.  Refer to Chapter 17 "SELECTING MODE".		

8.2 Executing a Layout

The following methods can be selected for executing a Layout:

- 1) Recalling points from internal memory by point number.
- 2) Direct key input of coordinate values.

Example setting: Recalling point from internal memory.

Operating procedure	Operation	Display
		<pre>LAYOUT 1/2 F1:OCC.PT INPUT F2:BACKSIGHT F3:LAYOUT P↓</pre>
1 Press the {F3} (LAYOUT) key from the layout menu 1/2.	{F3}	<pre>LAYOUT PT#: INPUT LIST NEZ ENTER</pre>
2 Press the {F1} (INPUT) key, and enter PT#. *1) Press the {F4} (ENT) key. *2)	{F1} Enter PT# {F4}	<pre>REFLECTOR HEIGHT INPUT R.HT = 0.000 m --- --- [CLR] [ENT]</pre>
3 Enter reflector height in the same way. When the layout point is set, the instrument will start layout calculation. HR: Calculated horizontal angle of the layout point HD: Calculated horizontal distance from the instrument to the layout point	Enter R.HT {F4}	<pre>CALCULATED HR= 90°10'20" HD= 123.456 m ANGLE DIST --- ---</pre>
4 Collimate the prism, and press the {F1} (ANGLE) key. PT#: Layout point HR: Measured (Actual) horizontal angle. dHR: Horizontal angle to be turned to the layout point = Actual horizontal angle - Calculated horizontal angle. Correct direction when dHR = 0°00'00"	Collimate P {F1}	<pre>PT#: LP-100 HR: 6°20'40" dHR: 23°40'20" DIST --- NEZ ---</pre>
5 Press the {F1} (DIST) key. HD: Measuring (Actual) horizontal distance dHD: Horizontal distance to be turned to the layout point = Actual horizontal distance – Calculated horizontal distance. dZ: Vertical distance to be turned to the layout point = Actual vertical distance – Calculated vertical distance.	{F1}	<pre>HD* [t] < m dHD: m dZ: m MODE NEZ NP/P NEXT</pre> <p style="text-align: center;">↓</p> <pre>HD* 110.12 m dHD: -13.34 m dZ: -0.05 m MODE NEZ NP/P NEXT</pre>
6 Press the {F1} (MODE) key. The fine mode measuring starts.	{F1}	<pre>HD* [r] < m dHD: m dZ: m MODE NEZ NP/P NEXT</pre> <p style="text-align: center;">↓</p> <pre>HD* 120.129 m dHD: -3.327 m dZ: -0.046 m MODE NEZ NP/P NEXT</pre>

8.2.1 Layout of Coordinates of Point to Line

The coordinate data of point to line can be used during execution of layout.

When a point name including PTL coordinates (including 'From' and 'To' data) is specified, the mode will change to PTL mode automatically.

There are two ways to enter the PTL coordinate data, Direct key input and Data transfer.

☞ Refer to 9.4.2 "PTL (Point to Line) data input" and 9.7 "Data Communications".

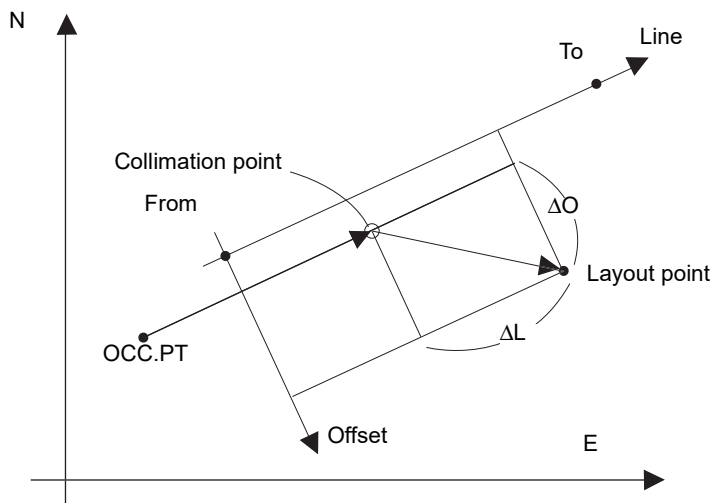

Operating procedure	Operation	Display
<p>1 Press the {F1} (INPUT) key, and enter PT#. Press the {F4} (ENT) key.</p>	<p>{F1} Enter PT# {F4}</p>	<pre>LAYOUT PT#: PT-21 INPUT LIST NEZ ENTER</pre>
<p>2 Enter reflector height in the same way.</p> <p>When the layout point is set, the instrument will start layout calculation. The {F3} (PTL) key will be assigned.</p>	<p>Enter R.HT {F4}</p>	<pre>REFLECTOR HEIGHT INPUT R.HT = 1.500 m --- --- [CLR] [ENT]</pre>
<p>3 Collimate the prism, and press the {F1} (ANGLE) key.</p>	<p>Collimate P {F1}</p>	<pre>CALCULATED HR= 45°10'20" HD= 1.500 m ANGLE DIST PTL ---</pre>
<p>4 Press the {F1} (DIST) key.</p> <p>HD: Measuring (Actual) horizontal distance dHD: Horizontal distance to be turned to the layout point = Actual horizontal distance – Calculated horizontal distance. dZ: Vertical distance to be turned to the layout point = Actual vertical distance – Calculated vertical distance.</p>	<p>{F1}</p>	<pre>HD* 143.84 m dHD: -13.34 m dZ: -0.05 m MODE PTL NP/P NEXT</pre>
<p>5 Press the {F2} (PTL) key.</p> <p>The difference between Collimation point and Layout point distance on the coordinate system of the line determined will be displayed.</p>	<p>{F2}</p>	<pre>dL: 0.005 m dO: 0.327 m dE: 0.046 m MODE ANGLE NP/P NEXT</pre>

8.3 Setting a New Point

New point is required for example when a layout point cannot be sighted from existing control points.

8.3.1 Side Shot Method

Set up the instrument at a known point, and measure the coordinate of the new points by the side shot method

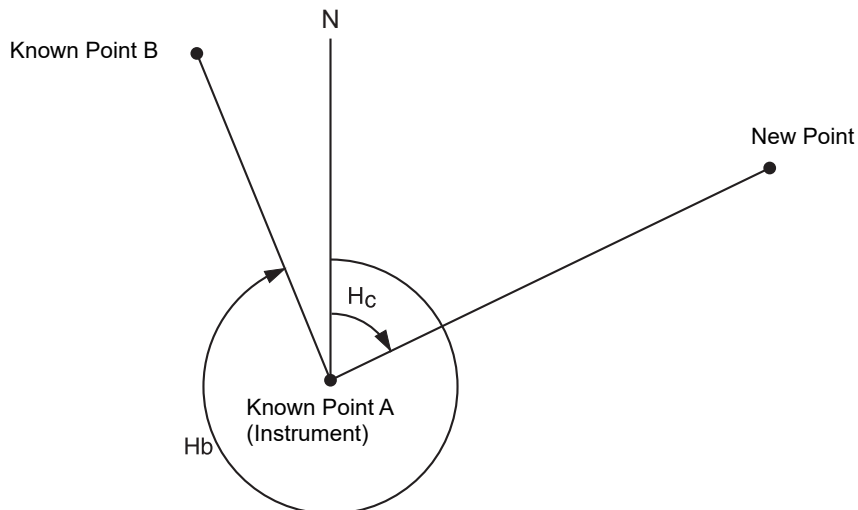

Operating procedure	Operation	Display
<p>1 Press the {F4} (↓) key from the layout menu 1/2 to get the layout menu 2/2.</p> <p>2 Press the {F2} (NEW POINT).</p> <p>3 Press the {F1} (SIDE SHOT) key.</p> <p>4 Press the {F2} (LIST) key to display the list of coordinate data file. *1)</p> <p>5 Scroll file list by pressing {▲} or {▼} key and select a file to use. *2),3)</p>	{F4}	<pre>LAYOUT 1/2 F1:OCC.PT INPUT F2:BACKSIGHT F3:LAYOUT P↓</pre>
		<pre>LAYOUT 2/2 F1:SELECT A FILE F2:NEW POINT F3:GRID FACTOR P↓</pre>
	{F2}	<pre>NEW POINT F1:SIDE SHOT F2:RESECTION</pre>
	{F1}	<pre>SELECT A FILE FN: _____ INPUT LIST ----ENTER</pre>
	{F2}	<pre>COORDDATA /C0123 →*TOKBDATA /C0345 TOPCDATA /C0789 --- SRCH --- ENTER</pre>
{▲} or {▼}	<pre>*TOKBDATA /C0345 → TOPCDATA /C0789 SATIDATA /C0456 --- SRCH --- ENTER</pre>	

<p>6 Press the {F4} (ENTER) key. The file will be set.</p>	{F4}	<pre>SIDE SHOT PT#: INPUT SRCH --- ENTER</pre>
<p>7 Press the {F1} (INPUT) key, and enter the new point name. *4) Press the {F4} (ENT) key.</p>	{F1} Enter PT# {F4}	<pre>REFLECTOR HEIGHT INPUT R.HT = 0.000 m --- --- [CLR] [ENT]</pre>
<p>8 Enter reflector height in the same way.</p>	Enter R.HT {F4}	<pre>REFLECTOR HEIGHT INPUT R.HT : 1.235 m MEAS --- NP/P ---</pre>
<p>9 Collimate the new point, and press the {F1} (MEAS) key. Distance measuring starts.</p>	Collimate {F1}	<pre>HR: 123°40'20" HD*[n] < m VD: m > Measuring... < complete ></pre>
<p>10 Press the {F3} (YES) key.*5) The name and coordinate value are stored into COORD.DATA. The input menu for next new point is displayed. PT# is automatically incremented.</p>	{F3}	<pre>N : 1234.567 m E : 123.456 m Z : 1.234 m >REC ? [YES] [NO]</pre> <p style="text-align: center;">↓</p> <pre>SIDE SHOT PT#: NP-101 INPUT SRCH --- ENTER</pre>
<p>*1) If you want to input file name directly, press the {F1} (INPUT) key and enter a file name. *2) When a file has been selected already, "*" mark is indicated on left of current file name. ☞ For the file discrimination mark (*, @, &), refer to Chapter 9.3 "File Maintenance". *3) Data in a file shown with arrow can be searched by pressing {F2} (SRCH) key. *4) ☞ Refer to Section 2.4 "How to Enter Alphanumeric Characters". *5) An error will be displayed when the internal memory is full.</p>		

8.3.2 Resection Method

Set up the instrument at a new point, and calculate the coordinate of the new point using the coordinate data of maximum seven known points and the measurements made to these points.

By following observation, resection is possible.

- Resection by distance measurement: 2 or more points must be measured
- Resection by angle measurement only: 3 or more points must be measured

An occupied point coordinate value will be calculated by the method of least squares.

(In case that 3 known points are measured by angle measurement only, the value would not be calculated by the method of least squares.)

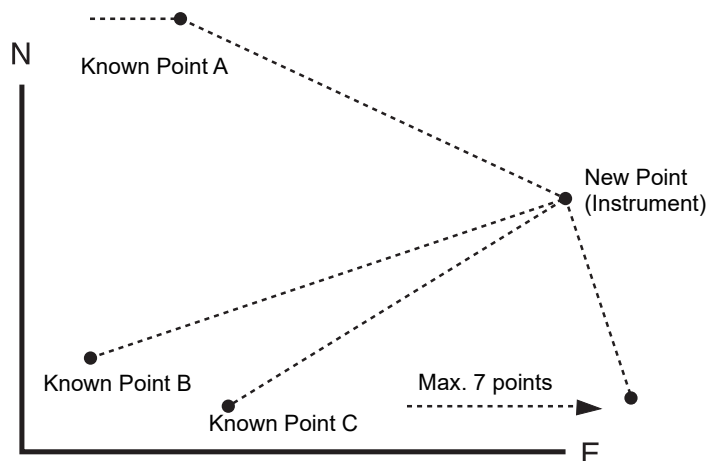

Operating procedure	Operation	Display
1 Press the {F4} (↓) key from the layout menu 1/2 to get the layout menu 2/2.	{F4}	<pre>LAYOUT 1/2 F1:OCC.PT INPUT F2:BACKSIGHT F3:LAYOUT P↓</pre>
2 Press the {F2} (NEW POINT).	{F2}	<pre>LAYOUT 2/2 F1:SELECT A FILE F2:NEW POINT F3:GRID FACTOR P↓</pre>
3 Press the {F2} (RESECTION) key.	{F2}	<pre>NEW POINT F1:SIDE SHOT F2:RESECTION</pre>
4 Press the {F1} (INPUT) key, and enter the new point name. *1), 2) Press the {F4} (ENT) key.	{F1} Enter PT# {F4}	<pre>NEW POINT PT#: _____ INPUT SRCH SKP ENTER</pre>
		<pre>INSTRUMENT HEIGHT INPUT INS.HT = 0.000 m --- --- [CLR] [ENT]</pre>

5 Enter instrument height in the same way.

6 Enter the known point A number. *3)

7 Enter reflector height.

8 Collimate the known point A, and press the **{F1}** (ANG) or **{F2}** (DIST) key.
Example: **{F2}** (DIST)
Distance measuring starts.

Known point B entering display will be shown.

9 Same as procedure **6** to **8** proceed to the known point B.

When two points have been measured by the **{F2}** (DIST) key, the RESIDUAL ERROR will be calculated. *4)

10 Select GRID FACTOR for calculation of RESIDUAL ERROR by pressing **{F1}** or **{F2}** key. *5)
Example: **{F1}**

11 Press the **{F1}** (NEXT) key to measure other points.
Maximum seven points can be measured.

12 Same as procedure **6** to **8** proceed to the known point C.

Enter
INS.HT
{F4}

{F1}
Enter PT#
{F4}

Enter R.HT
{F4}

Collimate A
{F2}

{F1}

{F1}

```
NO01#
PT#: _____
INPUT LIST NEZ ENTER
```

```
REFLECTOR HEIGHT
INPUT
R.HT = 0.000 m
--- --- [CLR] [ENT]
```

```
REFLECTOR HEIGHT
INPUT
R.HT : 1.235 m
ANG DIST NP/P ---
```

```
HR: 123°40'20"
HD*[n] < m
VD: m
> Measuring...
< complete >
```

```
NO02#
PT#: _____
INPUT LIST NEZ ENTER
```

```
SELECT GRID FACTOR
F1:USE LAST DATA
F2:CALC MEAS.DATA
```

```
RESIDUAL ERROR
dHD= 0.015 m
dZ = 0.005 m
NEXT --- G.F. CALC
```

```
NO03#
PT#: _____
INPUT LIST NEZ ENTER
```

```
HR: 123°40'20"
HD*[n] < m
VD: m
> Measuring...
< complete >
```

```
HR: 123°40'20"
HD: 123.456 m
VD: 1.234 m
NEXT --- --- CALC
```

<p>13 Press the {F4} (CALC) key. *6) Standard Deviation will be shown. Unit: (sec.) or (mGON) or (mMIL)</p>	<p>{F4}</p>	<table border="1"> <tr> <td colspan="2">Standard Deviation</td> </tr> <tr> <td>=</td> <td>1.23 sec.</td> </tr> <tr> <td>---</td> <td>↓ --- NEZ</td> </tr> </table>	Standard Deviation		=	1.23 sec.	---	↓ --- NEZ		
Standard Deviation										
=	1.23 sec.									
---	↓ --- NEZ									
<p>14 Press the {F2} (↓) key. Standard Deviations of each coordinate will be shown. Unit: (mm) or (inch) The display will be changed alternately by pressing {F2} (↓) or (↑) key.</p>	<p>{F2}</p>	<table border="1"> <tr> <td>SD (n) :</td> <td>1.23 mm</td> </tr> <tr> <td>SD (e) :</td> <td>1.23 mm</td> </tr> <tr> <td>SD (z) :</td> <td>1.23 mm</td> </tr> <tr> <td>---</td> <td>↑ --- NEZ</td> </tr> </table>	SD (n) :	1.23 mm	SD (e) :	1.23 mm	SD (z) :	1.23 mm	---	↑ --- NEZ
SD (n) :	1.23 mm									
SD (e) :	1.23 mm									
SD (z) :	1.23 mm									
---	↑ --- NEZ									
<p>15 Press the {F4} (NEZ) key. Coordinate data of the new point will be shown.</p>	<p>{F4}</p>	<table border="1"> <tr> <td>N :</td> <td>65.432 m</td> </tr> <tr> <td>E :</td> <td>876.543 m</td> </tr> <tr> <td>Z :</td> <td>1.234 m</td> </tr> <tr> <td>>REC ?</td> <td>[YES] [NO]</td> </tr> </table>	N :	65.432 m	E :	876.543 m	Z :	1.234 m	>REC ?	[YES] [NO]
N :	65.432 m									
E :	876.543 m									
Z :	1.234 m									
>REC ?	[YES] [NO]									
<p>16 Press the {F3} (YES) key. *7) The new point data will be stored into the coordinate data file and the value of occupied coordinate data will change to that of the calculated NEW POINT.</p>	<p>{F3}</p>	<table border="1"> <tr> <td colspan="2">NEW POINT</td> </tr> <tr> <td>F1 :</td> <td>SIDE SHOT</td> </tr> <tr> <td>F2 :</td> <td>RESECTION</td> </tr> </table>	NEW POINT		F1 :	SIDE SHOT	F2 :	RESECTION		
NEW POINT										
F1 :	SIDE SHOT									
F2 :	RESECTION									
<p>The display returns to new point menu.</p>										
<p>*1)  Refer to Section 2.4 "How to Enter Alphanumeric Characters".</p> <p>*2) When there is no need to memorize the new point data, press the {F3} (SKP) key.</p> <p>*3) To enter the known point coordinate data by direct key inputting, press the {F3} (NEZ) key.</p> <p>*4) RESIDUAL ERROR; dHD (Horizontal distance between two known points) = Measured value – Calculated value dZ = (Z coordinate of the new point calculated from known point A) – (Z coordinate of the new point calculated from known point B)</p> <p>*5) [F1:USE LAST DATA]; RESIDUAL ERROR is calculated with GRID FACTOR already set. [F2:CALC MEAS.DATA]; RESIDUAL ERROR is calculated without GRID FACTOR already set. In this case, new GRID FACTOR is calculated from measured data and reset." • To see the GRID FACTOR value, press the {F3} (G.F.) key.</p> <p>*6) In case that the all points are measured by angle measurement only, the following display will be shown. You can select Z coordinate calculation.</p>										
<table border="1"> <tr> <td colspan="2">CALC. Z COORD.</td> </tr> <tr> <td>F1 :</td> <td>YES</td> </tr> <tr> <td>F2 :</td> <td>NO</td> </tr> </table>			CALC. Z COORD.		F1 :	YES	F2 :	NO		
CALC. Z COORD.										
F1 :	YES									
F2 :	NO									
<p>F1(YES): :N,E,Z coordinates will be calculated with measured angle data. F2(NO): :N and E coordinates will be calculated with measured horizontal angle data. Z coordinate would not be calculated. (Z coordinate value =0.000 m)</p>										
<p>When the distance measurement is done even one point, Z coordinate will be calculated as a mean value of relative distance (vertical distance data).</p>										
<p>*7) The display shows ">SET ?" when {F3} (SKP) key pressed in step 4. In this case, the new point data is not stored into the coordinate data file, only the value of occupied coordinate data changes to that of the calculated NEW POINT.</p>										

● Viewing PT# LIST

You can see the PT# List and enter the data from the List, also you can see coordinate data of a point.
[Example: Executing Layout Mode]

Operating procedure	Operation	Display
<p>1 While executing the LAYOUT mode, press the {F2} (LIST) key. The arrow(→) indicates selected data.</p> <p>2 By pressing the following keys, the list will increase or decrease. {▲} or {▼}: Increasing or Decreasing one by one. {▶} or {◀}: By ten Increasing or Decreasing.</p> <p>3 To show the coordinate of the selected data, press the {F1} (VIEW) key. It is still possible to scroll the PT# data by pressing {▲} or {▼} key.</p> <p>4 Press the {ESC} key. The display returns to the List.</p> <p>5 Press the {F4} (ENTER) key. The selected point number is set as PT#.</p>	<p>{F2}</p> <p>{▲} or {▼} {▶} or {◀}</p> <p>{F1}</p> <p>{ESC}</p> <p>{F4}</p>	<pre>LAYOUT PT#: _____ INPUT LIST NEZ ENTER</pre>
		<pre>[TOPCON] →DATA-01 DATA-02 VIEW SRCH --- ENTER</pre>
		<pre>DATA-49 →DATA-50 DATA-51 VIEW SRCH --- ENTER</pre>
		<pre>PT# DATA-50 N] 100.234 m E] 12.345 m Z] 1.678 m</pre>
		<pre>DATA-49 →DATA-50 DATA-51 VIEW SRCH --- ENTER</pre>
<pre>REFLECTOR HEIGHT INPUT R.HT = 0.000 m --- --- [CLR] [ENT]</pre>		
<p>● The operation of {F2} (SRCH) is same as the "SEARCH" in the MEMORY MANAGER MODE. ☞ For more information, refer to Chapter 9 "MEMORY MANAGER MODE".</p>		

9 MEMORY MANAGER MODE

The following items for internal memory are available in this mode.

- 1) FILE STATUS : Checking the number of stored data / Remaining internal memory capacity.
- 2) SEARCH : Searching the recorded data.
- 3) FILE MAINTAN. : Deleting files / Editing file name
- 4) COORD. INPUT : Inputting coordinate data into Coord. data file.
- 5) DELETE COORD. : Deleting coordinate data from Coord. data file.
- 6) PCODE INPUT : Inputting PCODE DATA into PCODE Library
- 7) DATA TRANSFER : Sending measured data or coordinate data or PCODE Library data / Uploading coordinate data or PCODE Library data / Setting communication parameters
- 8) INITIALIZE : Initializing internal memory.

● Memory manager menu operation

By pressing the {MENU} key, the instrument will be in MENU 2/4 mode.

Press the {F1} (MEMORY MGR.) key, the menu of MEMORY MGR. 1/3 will be shown.

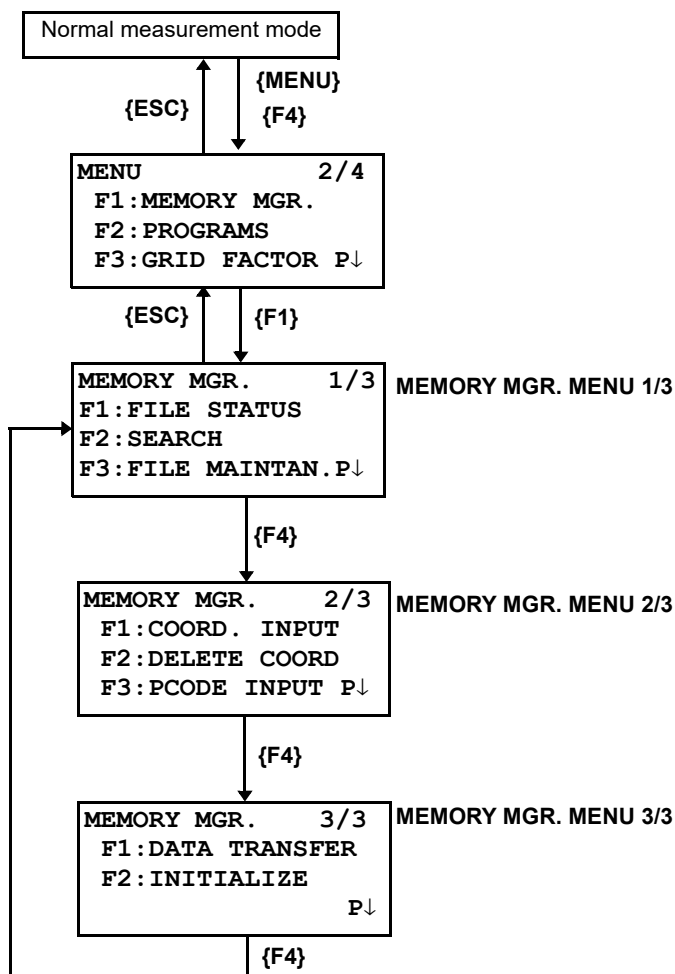

9.1 Display Internal Memory Status

This mode is used to check the internal memory status.

Operating procedure	Operation	Display
<p>1 Press the {F3} (MEMORY MGR.) key from the menu 1/3.</p>	<p>{F3}</p>	<pre> MEMORY MGR. 1/3 F1:FILE STATUS F2:SEARCH F3:FILE MAINTAN P↓ </pre>
<p>2 Press the {F1} (FILE STATUS) key.</p> <p>The total number of stored measured data files and coordinate I files are shown.</p>	<p>{F1}</p>	<pre> FILE STATUS 1/2 MEAS. FILE : 03 COORD. FILE: 06 [.....] P↓ </pre> <p style="text-align: center;">↑ Remaining memory capacity</p>
<p>3 Press the {F4} (P↓) key.</p> <p>The total number of stored measured data and coordinate data in all files are shown.*1)</p>	<p>{F4}</p>	<pre> DATA STATUS 2/2 MEAS. DATA :00100 COORD. DATA:00050 [.....] P↓ </pre>
<p>*1) Each coordinate file has one extra data for working area.</p> <p>Note</p> <ul style="list-style-type: none"> The FILE/DATA STATUS display will change alternately by pressing {F4} (P↓) key. To return to MEMORY MGR. menu press the {ESC} key. 		

9.2 Searching Data

This mode is used to search the recorded file data in the DATA COLLECT or LAYOUT mode. The following 3 search methods in each type of files can be selected.

- 1: First data search
- 2: Last data search
- 3: Point number search (MEAS.DATA, COORD.DATA)
Number search (PCODE LIB.)

MEAS. DATA : Measured data in the data collect mode.

COORD. DATA : Coordinate data for layout, control points and new point data measured in the layout mode.

PCODE LIB. : The data which was registered with a number from 1 to 50 in Point code library.

Point name (PT#, BS#), ID, PCODE and Height data (INS.HT, R.HT) can be corrected in the searching mode.

Measured value can not be corrected.

9.2.1 Measured Data Searching

Example: Point number searching

Operating procedure	Operation	Display
1 Press the {F3} (MEMORY MGR.) key from the menu 1/3.	{F3}	MEMORY MGR. 1/3 F1:FILE STATUS F2:SEARCH F3:FILE MAINTAN P↓
2 Press the {F2} (SEARCH) key.	{F2}	SEARCH F1:MEAS. DATA F2:COORD. DATA F3:PCODE LIB.
3 Press the {F1} (MEAS. DATA) key.	{F1}	SELECT A FILE FN: _____ INPUT LIST --- ENTER
4 Press the {F1} (INPUT) key and enter File Name. Press the {F4} (ENT) key. *1),2)	{F1} Enter FN {F4}	MEAS. DATA SEARCH F1:FIRST DATA F2:LAST DATA F3:PT# DATA
5 Press the {F3} (PT# DATA) key.	{F3}	PT# DATA SEARCH PT#= _____ [ALP] [SPC] [CLR] [ENT]
6 Enter PT#. Press the {F4} (ENT) key. *1)	Enter PT# {F4}	PT# TOP-104 1/2 V 98°36'20" HR 160°40'20" TILT 0°00'00" ↓

<p>7 Press the {F4} (↓) key to scroll data for selected point.</p>	<p>{F4}</p>	<pre>PT# TOP-104 2/2 PCODE R.HT 1.200 m EDIT ↓</pre>
<p>*1) Refer to Section 2.6 "How to enter alphanumeric characters". *2) To show the file list, press the {F2} (LIST) key.</p> <p>Note</p> <ul style="list-style-type: none"> • "↓" represents data shown on the display is the stored data. • Press the {▲} or {▼} key to scroll to next or previous point. • To search MEAS. DATA of the same point number, press {◀} or {▶} key. 		

● **To edit the data in searching mode**

Point name (PT#, BS#), ID, PCODE and Height data (INS.HT, R.HT) can be corrected in the searching mode.
 Measured value can not be corrected.

Operating procedure	Operation	Display
<p>1 Press the {F1} (EDIT) key from last page of displayed data.</p>	<p>{F1}</p>	<pre>PT# TOP-104 2/2 PCODE R.HT 1.000 m EDIT ↓</pre>
<p>2 Select the item to correct by pressing {▲} or {▼} key.</p>	<p>{▲} or {▼}</p>	<pre>PT# →TOP-104 PCODE : R.HT : 1.000 m INPUT --- --- ENTER</pre>
<p>3 Press the {F1} (INPUT) key and enter data. *1) Press the {F4} (ENT) key.</p>	<p>{F1} Enter Data</p>	<pre>PT# :TOP-104 PCODE : R.HT → 1.000 m INPUT --- --- ENTER</pre>
<p>4 Press the {F4} (ENTER) key.</p>	<p>{F4} {F4}</p>	<pre>PT# →TOP-104 PCODE : R.HT : 1.200 m >SAVE? [YES] [NO]</pre>
<p>5 Press the {F3} (YES) key.</p>	<p>{F3}</p>	<pre>PT# TOP-104 2/2 PCODE R.HT 1.200 m EDIT</pre>
<p>*1) Refer to Section 2.4 "How to Enter Alphanumeric Characters".</p> <p>Note</p> <ul style="list-style-type: none"> • When editing, ID and PCODE are not linked with PCODE LIBRARY. • Even though the height data (INS.HT, R.HT) are corrected, the measured value can not be corrected. 		

9.2.2 Coordinate Data Searching

Example searching: Point number searching

Operating procedure	Operation	Display
1 Press the {F3} (MEMORY MGR.) key from the menu 1/3.	{F3}	<pre> MEMORY MGR. 1/3 F1:FILE STATUS F2:SEARCH F3:FILE MAINTAN P↓ </pre>
2 Press the {F2} (SEARCH) key.	{F2}	<pre> SEARCH F1:MEAS. DATA F2:COORD. DATA F3:PCODE LIB. </pre>
3 Press the {F2} (COORD. DATA) key.	{F2}	<pre> SELECT A FILE FN: _____ INPUT LIST --- ENTER </pre>
4 Press the {F1} (INPUT) key and enter File Name. Press the {F4} (ENT) key. *1)	{F1} Enter FN {F4}	<pre> COORD. DATA SEARCH F1:FIRST DATA F2:LAST DATA F3:PT# DATA </pre>
5 Press the {F3} (PT# DATA) key.	{F3}	<pre> PT# DATA SEARCH PT#=# _____ [ALP] [SPC] [CLR] [ENT] </pre>
6 Enter PT#. Press the {F4} (ENT) key. *1)	Enter PT# {F4}	<pre> PT# TOP-104 1/2 N 100.234 m E 12.345 m Z 1.678 m ↓ </pre>
7 Press the {F4} (↓) key to get the next page.	{F4}	<pre> PCODE TOPS 2/2 STR. ↓ </pre>

*1)  Refer to Section 2.4 "How to Enter Alphanumeric Characters".

Note

- " | " represents data shown on the display is the stored data.
- Press the {▲} or {▼} key to scroll to next or previous point.
- To search COORD. DATA of the same point number, press the {◀} or {▶} key.
- PTL data will be shown below.

```

PT#|TOP-105      1/2
L | 10.000 m
O | 20.000 m
E | 0.000 m      ↓
                    
```

↑ {F4} ↓

```

PCODE | TOPS      2/2
STR.  |
FROM  | TOP-101
TO    | TOP-102   ↓
                    
```

9.2.3 PCODE LIBRARY Searching

Example searching: Number searching

Operating procedure	Operation	Display
1 Press the {F3} (MEMORY MGR.) key from the menu 1/3.	{F3}	<pre> MEMORY MGR. 1/3 F1:FILE STATUS F2:SEARCH F3:FILE MAINTAN P↓ </pre>
2 Press the {F2} (SEARCH) key.	{F2}	<pre> SEARCH F1:MEAS. DATA F2:COORD. DATA F3:PCODE LIB. </pre>
3 Press the {F3} (PCODE LIB.) key.	{F3}	<pre> PCODE DATA SEARCH F1:FIRST DATA F2:LAST DATA F3:No. SEARCH </pre>
4 Press the {F3} (No. SEARCH) key.	{F3}	<pre> PCODE No. SEARCH No.= --- --- [CLR] [ENT] </pre>
5 Enter number.Press the {F4} (ENT) key. *1) The number and linked data will be shown. *2)	Enter PT# {F4}	<pre> 011:NAKADAI →012:HILLTOP 013:ITABASH EDIT --- CLR --- </pre>
*1)  Refer to Section 2.4 "How to Enter Alphanumeric Characters". • Press the {▲} or {▼} key to scroll to next or PCODE data. *2) To correct the PCODE data, press the {F1} (EDIT) key. To delete the PCODE data, press the {F3} (CLR) key.		

9.3 File Maintenance

In this mode, the following items are available.
Renaming file name / Searching data in a file / Deleting files

- **FILE MAINTAN. menu**

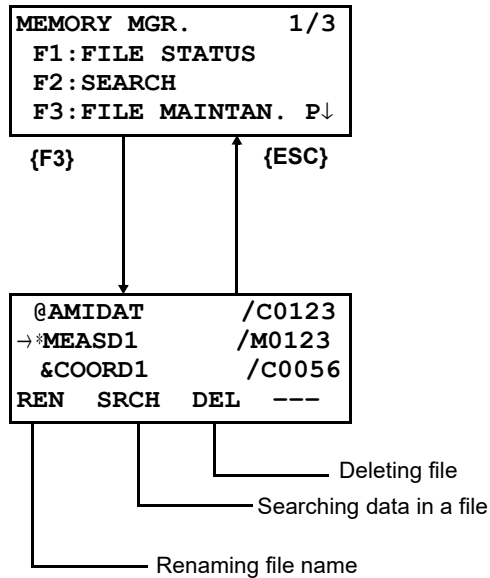

Pressing **{F3}** (FILE MAINTAN.) key from MEMORY MANAGER menu 1/3, file list will be shown.

- File discrimination mark (*,@,&)
File discrimination mark (*,@,&) placed before file name indicates the file status.
For measured data file
" * " selected file for DATA COLLECT mode.
For coordinate data file
" * " selected file for LAYOUT mode.
" @ " selected coordinate file for DATA COLLECT mode.
" & " selected coordinate file for both LAYOUT and DATA COLLECT mode.
- Data discrimination character (M, C)
Data discrimination character (M, C) placed before four figures indicates the type of data.
" M " : Measured data
" C " : Coordinate data.
- Four figures means the total number of data in the file.
(Coordinate data file has an extra data for working.)
Press the **{▲}** or **{▼}** key to scroll to next file.

9.3.1 Rename a File

An existing file in internal memory can be renamed.

Operating procedure	Operation	Display
1 Press the {F3} (FILE MAINTAN.) key from the Memory manager menu 1/3.	{F3}	<pre> →MEASD1 /M0123 COORD1 /C0056 REN SRCH DEL --- </pre>
2 Select a file by pressing {▲} or {▼} key.	{▲} or {▼}	<pre> MEASD1 /M0123 →COORD1 /C0056 COORD2 /C0098 REN SRCH DEL --- </pre>
3 Press the {F1} (REN) key.	{F1}	<pre> MEASD1 /M0123 =COORD1 /C0056 COORD1 /C0098 [ALP] [SPC] [CLR] [ENT] </pre>
4 Enter new file name. Press the {F4} (ENT) key. *1)	Enter FN {F4}	<pre> MEASD1 /M0123 →COORD5 /C0056 COORD1 /C0098 REN SRCH DEL --- </pre>
<p>*1)  Refer to Section 2.4 "How to Enter Alphanumeric Characters". Existing file name can not be available. To return to the FILE MAINTAN. Menu, press the {ESC} key.</p>		

9.3.2 Searching Data in a File

An existing file in internal memory can be searched.

Operating procedure	Operation	Display
1 Press the {F3} (FILE MAINTAN.) key from the Memory manager menu 1/3.	{F3}	<pre> →MEASD1 /M0123 COORD1 /C0056 REN SRCH DEL --- </pre>
2 Select a file to search by pressing {▲} or {▼} key.	{▲} or {▼}	<pre> MEASD1 /M0123 →COORD1 /C0056 COORD2 /C0098 REN SRCH DEL --- </pre>
3 Press the {F2} (SRCH) key.	{F2}	<pre> SEARCH [COORD1] F1: FIRST DATA F2: LAST DATA F3: PT# DATA </pre>
4 Select searching method by pressing the {F1} to {F3} key. *1)	{F1} to {F3}	
<p>*1) Because procedures from next are same as procedures of Section 9.2 "Searching Data", refer to Section 9.2 "Searching Data" To return to the FILE MAINTAN. Menu, press the {ESC} key.</p>		

9.3.3 Deleting a File

This mode erases a file from internal memory. Only one file can be erased at a time.

Operating procedure	Operation	Display
1 Press the {F3} (FILE MAINTAN.) key from the Memory manager menu 1/3.	{F3}	<pre> →MEASD1 /M0123 COORD1 /C0056 REN SRCH DEL --- </pre>
2 Select a file to delete by pressing {▲} or {▼} key.	{▲} or {▼}	<pre> MEASD1 /M0123 →COORD1 /C0056 COORD2 /C0098 REN SRCH DEL --- </pre>
3 Press the {F3} (DEL) key.	{F3}	<pre> MEASD1 /M0123 →COORD1 /C0056 COORD2 /C0098 >DELETE? [NO] [YES] </pre>
4 Confirm the deleting, and press the {F4} (YES) key.	{F4}	<pre> MEASD1 /M0123 →COORD2 /C0098 COORD3 /C0321 REN SRCH DEL --- </pre>
<ul style="list-style-type: none"> To return to the FILE MAINTAN. Menu, press the {ESC} key. 		

9.4 Coordinate Data Direct Key Input

9.4.1 Coordinate data input

Coordinate data for the layout point or control point can be input directly from the keyboard. This data can be stored into a file in the internal memory.

Operating procedure	Operation	Display
1 Press the {F3} (MEMORY MGR.) key from the menu 1/3.	{F3}	MEMORY MGR. 1/3 F1: FILE STATUS F2: SEARCH F3: FILE MAINTAN P↓
2 Press the {F4} (P↓) key.	{F4}	MEMORY MGR. 2/3 F1: COORD. INPUT F2: DELETE COORD. F3: PCODE INPUT P↓
3 Press the {F1} (COORD. INPUT) key.	{F1}	SELECT A FILE FN: _____ INPUT LIST --- ENTER
4 Press the {F1} (INPUT) key and enter File Name you want to input. Press the {F4} (ENT) key. *1)	{F1} Enter FN {F4}	COORD. DATA INPUT F1: NEZ F2: PTL
5 Select the kind of coordinates. NEZ: Coordinate data PTL: The coordinate data for point to line	{F1}	COORD. DATA INPUT PT#: _____ INPUT LIST --- ENTER
6 Press the {F1} (INPUT) key and enter PT#. Press the {F4} (ENT) key. *1)	{F1} Enter PT# {F4}	N= 100.234 m E: 12.345 m Z: 1.678 m --- --- [CLR] [ENT]
7 Enter data. Press the {F4} (ENT) key. *1)	Enter data {F4}	COORD. DATA INPUT PCODE: _____ INPUT LIST --- ENTER
8 Enter PCODE and press the {F4} (ENTER). Next input display is shown, point number (PT#) is automatically incremented.	{F1} Enter PCODE {F4}	COORD. DATA INPUT PT#: TOPCON-102 INPUT --- --- ENTER
*1)  Refer to Section 2.4 "How to Enter Alphanumeric Characters".		

9.4.2 PTL (Point to Line) data input

PTL Coordinate data for the layout point or control point can be input directly from the keyboard. This data can be stored into a file in the internal memory.

Operating procedure	Operation	Display
1 Press the {F3} (MEMORY MGR.) key from the menu 1/3.	{F3}	MEMORY MGR. 1/3 F1: FILE STATUS F2: SEARCH F3: FILE MAINTAN P↓
2 Press the {F4} (P↓) key.	{F4}	MEMORY MGR. 2/3 F1: COORD. INPUT F2: DELETE COORD. F3: PCODE INPUT P↓
3 Press the {F1} (COORD. INPUT) key.	{F1}	SELECT A FILE FN: _____ INPUT LIST --- ENTER
4 Press the {F1} (INPUT) key and enter File Name you want to input. Press the {F4} (ENT) key. *1)	{F1} Enter FN {F4}	COORD. DATA INPUT F1: NEZ F2: PTL
5 Select the kind of coordinates. NEZ: Coordinate data PTL: The coordinate data for point to line	{F2}	COORD. DATA INPUT PT#: _____ INPUT LIST --- ENTER
6 Press the {F1} (INPUT) key and enter PT#. Press the {F4} (ENT) key. *1)	{F1} Enter PT# {F4}	L= m O: m E: m --- --- [CLR] [ENT]
7 Enter data. Press the {F4} (ENT) key. *1) L: Line O: Offset E: Elevation Enter PCODE, FROM and TO data and press the {F4} (ENTER). *2) Next input display is shown, point number (PT#) is automatically incremented.	Enter data {F4} {F1} Enter PCODE {F4}	PCODE→ _____ FROM: _____ TO : _____ INPUT LIST --- ENTER COORD. DATA INPUT PT#: TOPCON-102 INPUT --- --- ENTER
*1)  Refer to Section 2.4 "How to Enter Alphanumeric Characters".		
*2) When the inputted point name data as FROM or TO, does not exist in the same file, an error will be displayed.		

9.5 Delete a Coordinate Data from a File

Coordinate data in a file can be erased.

Operating procedure	Operation	Display
1 Press the {F3} (MEMORY MGR.) key from the menu 1/3.	{F3}	<pre> MEMORY MGR. 1/3 F1:FILE STATUS F2:SEARCH F3:FILE MAINTAN P↓ </pre>
2 Press the {F4} (P↓) key.	{F4}	<pre> MEMORY MGR. 2/3 F1:COORD. INPUT F2:DELETE COORD. F3:PCODE INPUT P↓ </pre>
3 Press the {F2} (DELETE COORD.) key.	{F2}	<pre> SELECT A FILE FN: _____ INPUT LIST --- ENTER </pre>
4 Press the {F1} (INPUT) key and enter File Name. Press the {F4} (ENT) key. *1)	{F1} Enter FN {F4}	<pre> DELETE COORD. PT#: _____ INPUT LIST --- ENTER </pre>
5 Press the {F1} (INPUT) key and enter PT#. Press the {F4} (ENT) key. *1)	{F1} Enter PT# {F4}	<pre> N: 100.234 m E: 12.345 m Z: 1.678 m >DELETE? [YES][NO] </pre>
6 Confirm the data and press the {F3} (YES) key. Deleting starts. The display will return to the previous display.	{F3}	
*1)  Refer to Section 2.4 "How to Enter Alphanumeric Characters".		
<p>Note</p> <ul style="list-style-type: none"> Even if an individual coordinate data is deleted, the internal memory usage does not change. Delete the file including coordinate data to decrease the memory usage. 		

9.6 Editing PCODE Library

PCODE data can be entered into PCODE Library in this mode.
 A PCODE is linked with a number of 1 to 50
 PCODE can be also edited in DATA COLLECT menu 2/3 in the same way.

Operating procedure	Operation	Display
1 Press the {F3} (MEMORY MGR.) key from the menu 1/3.	{F3}	<pre> MEMORY MGR. 1/3 F1:FILE STATUS F2:SEARCH F3:FILE MAINTAN. P↓ </pre>
2 Press the {F4} (P↓) key.	{F4}	<pre> MEMORY MGR. 2/3 F1:COORD. INPUT F2:DELETE COORD. F3:PCODE INPUT P↓ </pre>
3 Press the {F3} (PCODE INPUT) key.	{F3}	<pre> →001:TOPCON 002:TOKYO EDIT --- CLR --- </pre>
4 By pressing the following keys, the list will increase or decrease. {▲} or {▼} : Increasing or Decreasing one by one. {▶} or {◀} : By ten Increasing or Decreasing.	{▲} or {▼} {▶} or {◀}	<pre> 011:URAH →012:AMIDAT 013:HILLTO EDIT --- CLR --- </pre>
5 Press the {F1} (EDIT) key.	{F1}	<pre> 011:URAH →012=<u>A</u>MIDAT 013:HILLTO [ALP] [SPC] [CLR] [ENT] </pre>
6 Enter PCODE and press the {F4} (ENT) key. *1)	Enter PCODE {F4}	<pre> 011:URAH →012:AMISUN 013:HILLTO EDIT --- CLR --- </pre>
*1)  Refer to Section 2.4 "How to Enter Alphanumeric Characters".		

9.7 Data Communications

You can send a data file stored in the internal memory to a computer directly. Also, you can directly load a coordinate data file and PCODE Library data to the internal memory from the computer.

9.7.1 Sending Data

Example: Sending a Measured data file

Operating procedure	Operation	Display
1 Press the {F3} (MEMORY MGR.) key from the menu 1/3.	{F3}	<pre> MEMORY MGR. 1/3 F1:FILE STATUS F2:SEARCH F3:FILE MAINTAN P↓ </pre>
2 Press the {F4} (P↓) key twice.	{F4} {F4}	<pre> MEMORY MGR. 3/3 F1:DATA TRANSFER F2:INITIALIZE P↓ </pre>
3 Press the {F1} (DATA TRANSFER) key.	{F1}	<pre> SELECT COM [F1:BLUETOOTH] F2:RS-232C F3:USB ENTER </pre>
4 Press the {F2} (RS-232C) key.*1)	{F2}	
5 Press the {F4} (ENTER) key.	{F4}	<pre> DATA TRANSFER F1:GTS FORMAT F2:SSS FORMAT </pre>
6 Select data format. GTS format: The conventional data SSS format: Including PCODE data, 'From' and 'To' data for Point to Line.	{F1}	<pre> DATA TRANSFER F1:SEND DATA F2:LOAD DATA F3:COMM. PARAMETERS </pre>
7 Press the {F1} (SEND DATA) key.	{F1}	<pre> SEND DATA F1:MEAS. DATA F2:COORD. DATA F3:PCODE DATA </pre>
8 Select the type of data to send by pressing {F1} - {F3} key. Example: {F1} (MEAS. DATA)	{F1}	<pre> SELECT A FILE FN: _____ INPUT LIST --- ENTER </pre>
9 Press the {F1} (INPUT) key and enter File Name you want to send. Press the {F4} (ENT) key. *2),3),4)	{F1} Enter FN {F4}	<pre> SEND MEAS. DATA >OK ? ---- ---- [YES] [NO] </pre>

10 Press the **{F3}** (YES) key.*5)
The sending starts.
The display will return to menu.

{F3}

```
SEND MEAS. DATA
< Sending Data!>
STOP
```

- *1) Only for *Bluetooth* function built-in models.
- *2)  Refer to Section 2.4 "How to Enter Alphanumeric Characters".
- *3) To scroll the data, press the **{▲}** or **{▼}** key.
- *4) To show the file list, press the **{F2}** (LIST) key.
- *5) To cancel the sending, press the **{F4}** (STOP) key.

9.7.2 Loading Data

Coordinate data files and PCODE Library data can be loaded from PC.

Example: Loading a coordinate data file (from PC)

Operating procedure	Operation	Display
1 Press the {F3} (MEMORY MGR.) key from the menu 1/3.	{F3}	<pre> MEMORY MGR. 1/3 F1:FILE STATUS F2:SEARCH F3:FILE MAINTAN P↓ </pre>
2 Press the {F4} (P↓) key twice.	{F4} {F4}	<pre> MEMORY MGR. 3/3 F1:DATA TRANSFER F2:INITIALIZE P↓ </pre>
3 Press the {F1} (DATA TRANSFER) key.	{F1}	<pre> SELECT COM [F1:BLUETOOTH] F2:RS-232C F3:USB ENTER </pre>
4 Press the {F2} (RS-232C) key.*1)	{F2}	
5 Press the {F4} (ENTER) key.	{F4}	<pre> DATA TRANSFER F1:GTS FORMAT F2:SSS FORMAT </pre>
6 Press the {F1} (GTS FORMAT) key.	{F1}	<pre> DATA TRANSFER F1:SEND DATA F2:LOAD DATA F3:COMM. PARAMETERS </pre>
7 Press the {F2} (LOAD DATA) key.	{F2}	<pre> LOAD DATA F1:COORD. DATA F2:PCODE DATA </pre>
8 Select the type of data to load by pressing {F1} or {F2} key. Example: {F1} (COORD. DATA)	{F1}	<pre> COORD. FILE NAME FN=_____ [ALP] [SPC] [CLR] [ENT] </pre>
9 Enter New File Name you want to receive. Press the {F4} (ENT) key. *1)	Enter FN {F4}	<pre> LOAD COORD. DATA >OK ? --- --- [YES] [NO] </pre>
10 Press the {F3} (YES) key.*2) The loading starts. The display will return to menu.	{F3}	<pre> LOAD COORD. DATA < Loading Data!> STOP </pre>

*1) Only for *Bluetooth* function built-in models.
*2)  Refer to Section 2.4 "How to Enter Alphanumeric Characters".
*3) To cancel the loading, press the **{F4}** (STOP) key.

9.7.3 Setting Parameter of Data Communications

● Items of the Parameter

Item	Selecting Item	Contents
F1: Protocol	[ACK/NAK], [ONE WAY]	Setting Protocol [ACK/NAK] or [ONE WAY] communication
F2: Baud rate	1200, 2400, 4800, 9600, 19200, 38400	Setting transfer speed 1200/2400/4800/9600/19200/38400 baud
F3: Char. / Parity	[7/EVEN], [7/ODD], [8/NON]	Setting data length and parity. [7bit, even], [7bit, odd], [8bit, none]
F1: Stop Bits	1, 2	Setting Stop 1 bit or 2bits

● Example Setting Baud rate: 19200 baud

Operating procedure	Operation	Display
1 Press the {F3} (MEMORY MGR.) key from the menu 1/3.	{F3}	<pre> MEMORY MGR. 1/3 F1:FILE STATUS F2:SEARCH F3:FILE MAINTAN P↓ </pre>
2 Press the {F4} (P↓) key twice.	{F4} {F4}	<pre> MEMORY MGR. 3/3 F1:DATA TRANSFER F2:INITIALIZE P↓ </pre>
3 Press the {F1} (DATA TRANSFER) key.	{F1}	<pre> SELECT COM [F1:BLUETOOTH] F2:RS-232C F3:USB ENTER </pre>
4 Press the {F2} (RS-232C) key. *1)	{F2}	
5 Press the {F4} (ENTER) key.	{F4}	<pre> DATA TRANSFER F1:GTS FORMAT F2:SSS FORMAT </pre>
6 Press the {F1} (GTS FORMAT) key.	{F1}	<pre> DATA TRANSFER F1:SEND DATA F2:LOAD DATA F3:COMM. PARAMETERS </pre>
7 Press the {F3} (COMM. PARAMETERS) key.	{F3}	<pre> COMM. PARAMETERS 1/2 F1:PROTOCOL F2:BAUD RATE F3:CHAR./PARITY P↓ </pre>
8 Press the {F2} (BAUD RATE) key. [] indicates present setting.	{F2}	<pre> BAUD RATE [1200] 2400 4800 9600 19200 38400 ENTER </pre>
9 Select the items by pressing {▲} or {▼} , {◀} and {▶} keys. *2)	{▶} {▼}	<pre> BAUD RATE 1200 2400 4800 9600 [19200] 38400 ENTER </pre>

10 Press the {F4} (ENTER) key.	{F4}	<table border="1"> <tr> <td>COMM. PARAMETERS 1/2</td> </tr> <tr> <td>F1: PROTOCOL</td> </tr> <tr> <td>F2: BAUD RATE</td> </tr> <tr> <td>F3: CHAR. / PARITY P↓</td> </tr> </table>	COMM. PARAMETERS 1/2	F1: PROTOCOL	F2: BAUD RATE	F3: CHAR. / PARITY P↓
COMM. PARAMETERS 1/2						
F1: PROTOCOL						
F2: BAUD RATE						
F3: CHAR. / PARITY P↓						
<p>*1) Only for <i>Bluetooth</i> function built-in models. *2) To cancel setting, press the {ESC} key.</p>						

9.7.4 Confirming the parameters for *Bluetooth* communication (Only for *Bluetooth* function built-in models)

The communication parameters for the *Bluetooth* are fixed as follows. You can only confirm the parameters in Memory manager mode.

- Fixed parameters for *Bluetooth* communication

Item	Fixed parameters
Baud rate	38400 baud (Maximum effective speed)
Char. / Parity	8bit, none
Stop Bits	Stop 1 bit

9.8 Initialization

This mode is used to initialize the internal memory.
Following data can be initialized.

FILE DATA : All files of measuring data and coordinate data
PCODE DATA : PCODE LIST
ALL DATA : FILE DATA and PCODE DATA



- The following data are not initialized even if initialization is executed.
: Coordinates of the instrument, Instrument height and Reflector height.

Example Initialization: ALL DATA (FILE data and PCODE data)

Operating procedure	Operation	Display
1 Press the {F3} (MEMORY MGR.) key from the menu 1/3.	{F3}	<pre>MEMORY MGR. 1/3 F1:FILE STATUS F2:SEARCH F3:FILE MAINTAN. P↓</pre>
2 Press the {F4} (P↓) key twice.	{F4} {F4}	<pre>MEMORY MGR. 3/3 F1:DATA TRANSFER F2:INITIALIZE P↓</pre>
3 Press the {F2} (INITIALIZE) key.	{F2}	<pre>INITIALIZE F1:FILE AREA F2:PCODE LIST F3:ALL DATA</pre>
4 Select the data to initialize by pressing one of the {F1} to {F3} key. Example: {F3} (ALL DATA)	{F3}	<pre>INITIALIZE DATA ERASE ALL DATA ! >OK ? [NO] [YES]</pre>
5 Confirm the erase data, press the {F4} (YES) key. Initializing will start. The display returns to menu.	{F4}	<pre>INITIALIZE DATA <Initializing!></pre> <p style="text-align: center;">↓</p> <pre>MEMORY MGR. 3/3 F1:DATA TRANSFER F2:INITIALIZE P↓</pre>

10 SETTING THE PRISM CONSTANT VALUE

The prism constant value of Topcon is set to zero. When using prisms other than Topcon's, it is necessary to set the prism constant correction value of that specific prism.

Once you set the correction value for prism constant, it is retained after power is OFF.



- Confirm the non-prism constant value is set at 0 when measuring target such as walls in Non-prism mode.

● Prism constant correction

Reflective prisms each have their prism constant.

Set the prism constant correction value of the reflective prism you are using. The prism constant correction value is a value that the prism constant is inverted to positive or negative. (E.g. if the prism constant is 40 mm, the correction value turns to -40 mm.)

Operating procedure	Operation	Display
<p>1 Press the {F4} key to get the soft key page 2 in the distance measurement mode or page 3 in the coordinate measurement.</p>	{F4}	<pre> HR: 120°30'40" HD* 123.456 m VD: 5.678 m MEAS MODE NP/P P1↓ OFFSET S.O S/A P2↓ </pre>
<p>2 Press the {F3} (S/A).</p>	{F3}	<pre> PSM:0.0 PPM 0.0 NPM:0.0 SHT: 0.0 SIGNAL: [] PRISM PPM T-P --- </pre>
<p>3 Press the {F1} (PRISM) key.</p>	{F1}	<pre> PRISM =0.0 mm N_PSM : 0.0 mm SHEET : 0.0 mm --- --- [CLR] [ENT] </pre>
<p>4 Input prism constant correction value. Press {F4} (ENT) to move to the next item. PRISM: Prism Constant Correction Value N_PSM: Non-prism Constant Correction Value SHEET: Sheet Constant Correction Value</p> <p>When all the values are set, previous screen is restored.</p>	Enter value {F4}	<pre> PRISM : 14.0 mm N_PSM =0.0 mm SHEET : 0.0 mm --- --- [CLR] [ENT] </pre>
		<pre> PSM:14.0 PPM 0.0 NPM:0.0 SHT: 0.0 SIGNAL: [] PRISM PPM T-P --- </pre>
<p>*1) Refer to Section 2.4 "How to Enter Alphanumeric Characters".</p> <ul style="list-style-type: none"> ● Input range: -99.9 mm to 99.9 mm, 0.1 mm step. 		

11 SET AUDIO MODE

The light acceptance quantity level for the EDM (SIGNAL), the atmospheric correction value (PPM), and prism constant correction value of each target are displayed in this mode.

When reflected light from the prism is received a buzzer sounds. This function is good for easy collimation when the target is difficult to find.

Operating procedure	Operation	Display
<p>1 Press the {F4} key to get the soft key page 2 in the distance measurement mode or page 3 in the coordinate measurement.</p>	{F4}	<pre> HR: 120° 30' 40" HD* 123.456 m VD: 5.678 m MEAS MODE NP/P P1↓ OFSET S.O S/A P2↓ </pre>
<p>2 Press the {F3} (S/A) key to change to set audio mode.</p> <p>The display indicates correction value of prism constant (PSM), non-prism constant (NPM), sheet constant (SHT), atmospheric correction (PPM) and reflection light level (SIGNAL).</p>	{F3}	<pre> PSM: 0.0 PPM 0.0 NPM: 0.0 SHT: 0.0 SIGNAL: [] PRISM PPM T-P --- </pre>
<ul style="list-style-type: none"> ● When receiving reflected light, buzzer sounds. It is possible to stop the sound, see Chapter 17 "SELECTING MODE" . ● The {F1} to {F3} keys are used for setting atmospheric correction and prism constant. ● To return to normal measuring mode, press the {ESC} key. 		

12 SETTING ATMOSPHERIC CORRECTION

The velocity of the light beam used for measurement varies according atmospheric conditions such as temperature and air pressure. Set the atmospheric correction factor when you wish to take this influence into account when measuring.

The GM is designed so that the correction factor is 0 ppm at an air pressure of 1013.25hPa, a temperature of 15°C, and a humidity of 50%.

The values are kept in the memory even after power is OFF.

12.1 Calculation of Atmospheric Correction

The velocity of the light beam used for measurement varies according atmospheric conditions such as temperature and air pressure. Set the atmospheric correction factor when you wish to take this influence into account when measuring.

- The instrument is designed so that the correction factor is 0 ppm at an air pressure of 1013.25 hPa, a temperature of 15°C, and a humidity of 50%.
- By inputting the temperature, air pressure values and humidity, the atmospheric correction value is calculated using the following formula and set into the memory.

Atmospheric Correction Factor (ppm) =

$$282.324 - \frac{0.294280 \times p}{1 + 0.003661 \times t} + \frac{0.04126 \times e}{1 + 0.003661 \times t}$$

t : Air temperature (°C)

p : Pressure (hPa)

e : Water vapor pressure (hPa)

h : Relative humidity (%)

E : Saturated water vapor pressure

- e (water vapor pressure) can be calculated using the following formula

$$e = h \times \frac{E}{100}$$

$$E = 6.11 \times 10^{\frac{(7.5 \times t)}{(t + 237.3)}}$$

- The instrument measures the distance with a beam of light, but the velocity of this light varies according to the index of refraction of light in the atmosphere. This index of refraction varies according to the temperature and pressure. Near normal temperature and pressure conditions:
With constant pressure, a temperature change of 1°C: an index change of 1 ppm.
With constant temperature, a pressure change of 3.6 hPa: an index change of 1 ppm.
To perform high accuracy measurements, it is necessary to find the atmospheric correction factor from even more accurate temperature and pressure measurements and perform an atmospheric correction.
It is recommended that extremely precise instruments be used to monitor the air temperature and pressure.
- Enter the average temperature, air pressure and humidity along the measurement beam route in "Temperature", "Pressure" and "Humidity".
Flat terrain :Use the temperature, pressure and humidity at the midpoint of the line.
Mountainous terrain :Use the temperature, pressure and humidity at the intermediate point (C).

If it is not possible to measure the temperature, pressure and humidity at the midpoint, take such measurements at the instrument station (A) and the target station (B), then calculate the average value.

Average air temperature : $(t_1 + t_2)/2$
Average air pressure : $(p_1 + p_2)/2$
Average humidity : $(h_1 + h_2)/2$

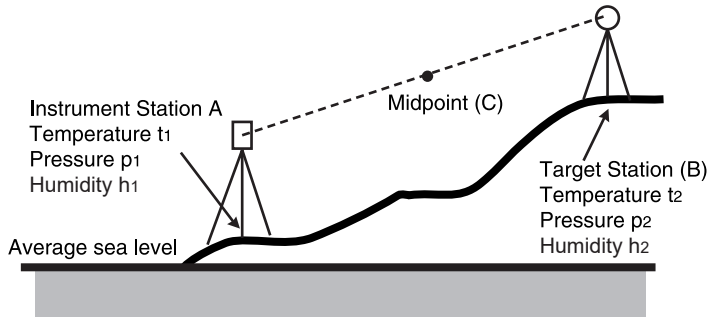

- If the weather correction is not required, set the ppm value to 0.

12.2 Setting of Atmospheric Correction Value

• How to set temperature, pressure and humidity value directly

Measure the temperature, pressure and humidity surrounding the instrument beforehand.



- Factory setting for humidity input is "OFF". In this case, atmospheric correction factor is calculated assuming humidity is 50%. To input arbitrary value for humidity, set humidity input to "ON" in advance.

☞ see Section 6.4.8 "Humidity Input ON/OFF Setting".

```

TEMP. =15.0    °C
PRES. : 1013.3 hPa
HUMID.: ( 50.0 ) %
--- --- [CLR] [ENT]
    
```

Screen of humidity input OFF

Example: Temperature: 26°C, Pressure:1017hPa, Humidity: 45%

Operating procedure	Operation	Display
1 Press the {F4} key to get the soft key page 2 in the distance measurement mode or page 3 in the coordinate measurement.	{F4}	<pre> HR: 120°30'40" HD* 123.456 m VD: 5.678 m MEAS MODE NP/P P1↓ OFFSET S.O S/A P2↓ </pre>
2 Press the {F3} (S/A) key to set Set Audio Mode from distance or coordinate measurement mode.	{F3}	<pre> PSM:0.0 PPM 0.0 NPM:0.0 SHT: 0.0 SIGNAL: [] PRISM PPM T-P --- </pre>
3 Press the {F3} (T-P) key.	{F3}	<pre> TEMP. =15.0 °C PRES. : 1013.3 hPa HUMID.: 50.0 % --- --- [CLR] [ENT] </pre>

<p>4 Input temperature, pressure, and humidity values.*1) Mode returns to Set Audio mode.</p>	<p>Enter Temp. Enter Pres.</p>	<pre>TEMP. : 26.0 °C PRES. : 1017.0 hPa HUMID.: 45.0 % INPUT --- --- ENTER</pre>
<p>*1) Refer to Section 2.4 "How to Enter Alphanumeric Characters".</p> <ul style="list-style-type: none"> ● Range: Temp. -30.0 to 60.0°C (0.1°C step) or -22.0 to 140.0°F (0.1°F step) Pres. 560.0 to 1066.0hPa (0.1hPa step), 420.0 to 800.0mmHg (0.1mmHg step) or 16.50 to 31.50inHg (0.01inHg step) Humid. 0.0 to 100.0% (0.1% step) 		

● **How to Set the Atmospheric Correction Value Directly**

Measure the temperature and air pressure to find atmospheric correction value (PPM) from the chart or correction formula.

Operating procedure	Operation	Display
<p>1 Press the {F4} key to get the soft key page 2 in the distance measurement mode or page 3 in the coordinate measurement.</p>	<p>{F4}</p>	<pre>HR: 120°30'40" HD* 123.456 m VD: 5.678 m MEAS MODE NP/P P1↓ OFFSET S.O S/A P2↓</pre>
<p>2 Press the {F3} (S/A) key to set Set Audio Mode from distance or coordinate measurement mode.</p>	<p>{F3}</p>	<pre>PSM:0.0 PPM 0.0 NPM:0.0 SHT: 0.0 SIGNAL: [] PRISM PPM T-P ---</pre>
<p>3 Press the {F2} (PPM) key. Current setting value is displayed.</p>	<p>{F2}</p>	<pre>PPM SET PPM = 0.0 ppm --- --- [CLR] [ENT]</pre>
<p>4 Enter atmospheric correction value. *1) Mode returns to Set Audio mode.</p>	<p>Enter Data {F4}</p>	
<p>*1) Refer to Section 2.4 "How to Enter Alphanumeric Characters".</p> <ul style="list-style-type: none"> ● Input range: -999.9 ppm to 999.9 ppm,0.1 ppm step 		

13 CORRECTION FOR REFRACTION AND EARTH CURVATURE

The instrument measures distance, taking into account correction for refraction and earth curvature.

13.1 Distance Calculation Formula

Distance Calculation Formula; with correction for refraction and earth curvature taken into account. Follow the Formula below for converting horizontal and vertical distances.

Horizontal distance $D = AC(\alpha)$

Vertical distance $Z = BC(\alpha)$

$D = L\{\cos\alpha - (2\theta - \gamma)\sin\alpha\}$

$Z = L\{\sin\alpha + (\theta - \gamma)\cos\alpha\}$

$\theta = L \cdot \cos\alpha / 2R$: Earth curvature correcting item

$\gamma = K \cdot L \cos\alpha / 2R$: Atmospheric refraction correcting item

$K = 0.14$ or 0.20 : Coefficient of refraction

$R = 6371$ km : Radius of earth

α : Altitude angle

L : Slope distance

- ☞ Changing "K (Coefficient of refraction)" value : see Chapter 17 "SELECTING MODE" .

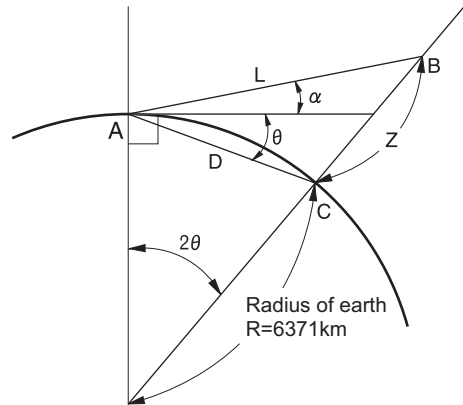

14 POWER SOURCE AND CHARGING

14.1 Battery Charging

Be sure to charge the battery fully before using it for the first time or after not using it for long periods.



- The charger will become rather hot during use. This is normal.
- Do not use to charge batteries other than those specified.
- The charger is for indoor use only. Do not use outdoors.
- Batteries cannot be charged when the temperature is outside the charging temperature range. Be sure to charge the battery within the charging temperature range.
- Do not charge the battery just after charging is completed. Battery performance may decline.
- Remove batteries from the charger before putting into storage.
- When not in use, disconnect the power cable plug from the wall outlet.
- Store the battery in a dry room where the temperature is within the following ranges. For long-term storage, the battery should be charged at least once every six months.

Storage period	Temperature range
1 month or less	-20 to 50°C
1 month to 3 months	-20 to 40°C
3 months to 1 year	-20 to 20°C

- Batteries generate power using a chemical reaction and as a result have a limited lifetime. Even when in storage and not used for long periods, battery capacity deteriorates with the passage of time. This may result in the operating time of the battery shortening despite having been charged correctly. In this event, a new battery is required.

● PROCEDURE

- 1 Connect the power cable to the charger and plug the charger into the wall outlet.
- 2 Mount the battery in the charger by matching the grooves on the battery with the guides on the charger.
When charging starts, the lamp starts flashing in green.
Charging takes approximately 4 hours (BDC71: 25°C).
The lamp lights up in green when charging is finished.
- 3 Remove the battery and unplug the charger.

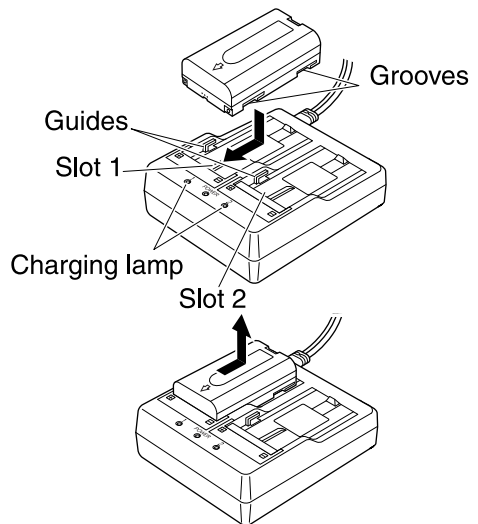

Note

- Slots 1 and 2: The battery charger can hold and charge up to two batteries at the same time.
- Charging time (at 25°C, when two batteries are charged at the same time):
 BDC71 : about 4 hours
 BDC72 (optional accessory) : about 8 hours
 (Charging can take longer than the times stated above when temperatures are either especially high or low).

- Charging lamp:

LED	Description
Green lamp flashing	On charge
Green lamp lit	Fully charged
Yellow lamp flashing	Battery temperature is out of charging temperature range. Charge the battery again within the charging temperature range. If the yellow lamp still does not stop flashing, contact your local dealer.
Off	The battery is not correctly mounted. Mount it again correctly. If the lamp is still off, contact your local dealer.
Red lamp lit	Charging is not being normally performed. There may be trouble with the charger or battery. Contact your local dealer.

14.2 Installing/Removing the Battery

Mount the charged battery.

☞ Type of power source: see Chapter 21 "BATTERY SYSTEM" .



- Use the provided battery BDC71/BDC72 (optional accessory) for this instrument.
- When removing the battery, turn the power off.
- When installing/removing the battery, make sure that moisture or dust particles do not come in contact with the inside of the instrument.
- Waterproofing property for this instrument is not secured unless the battery cover and external interface hatch are closed, and the connector caps are correctly attached. Do not use it with these open or loose, under the condition where water or other liquid spills over the instrument. The specification grade for water proofing and dust resistance is not guaranteed when using USB connector.
- Remove batteries from the surveying instrument or charger before putting into storage.

● PROCEDURE

- 1 Slide the catch on the battery cover to open.

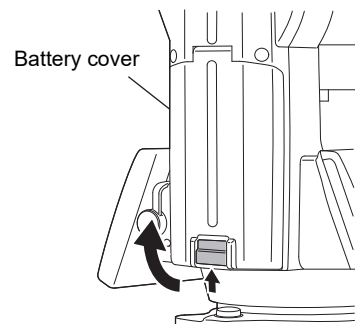

- 2 Insert the battery with the arrow shown on it downward while pressing toward the instrument.



- Inserting the battery aslant may damage the instrument or the battery terminal.

- 3 Close the cover. Listen for the click to ensure that the cover is properly closed.

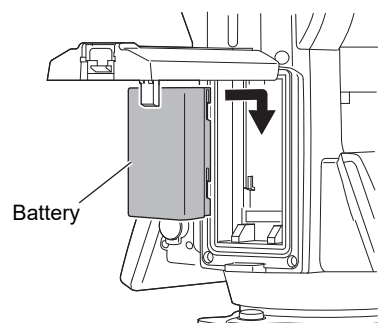

15 USING USB FLASH DRIVE

It is possible to read in/output data from/to a USB flash drive.

- When using a USB flash drive, data is stored in the root folder. You cannot read/write data from/to subfolders.
- When using the GM, an MS-DOS-compatible text file can be input/output.
- If the following characters are included in the current job name or file name, data can not be output to the USB flash drive. : slash (/), plus sign (+) , question mark (?), asterisk (*)
- You can neither save a file under the same name as a read-only file, nor change/delete the name of a read-only file. (However, this varies depending on the model or software you are using.)
- For "Communication Manual" that describes details on the communication formats used for inputting/outputting data to/from a USB flash drive, please consult with your local dealer.

15.1 Inserting the USB flash drive



- Do not remove the USB flash drive during data read/write. Doing so will cause data stored in the USB flash drive or the GM to be lost.
- Do not remove the battery or turn OFF the power during data read/write. Doing so will cause data stored in the USB flash drive or the GM to be lost.
- Waterproofing property for this instrument is not secured unless the battery cover and external interface hatch are closed, and the connector caps are correctly attached. Do not use it with these open or loose, under the condition where water or other liquid spills over the instrument. The specification grade for water proofing and dust resistance is not guaranteed when using USB connector.

● PROCEDURE Inserting USB Flash Drive

1 Open the external interface hatch.

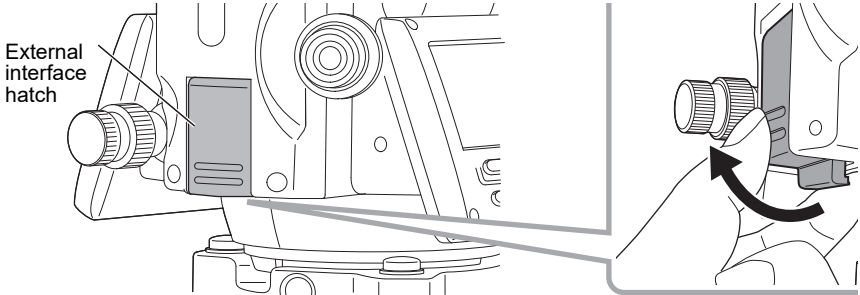

2 Insert the USB flash drive in the USB port.

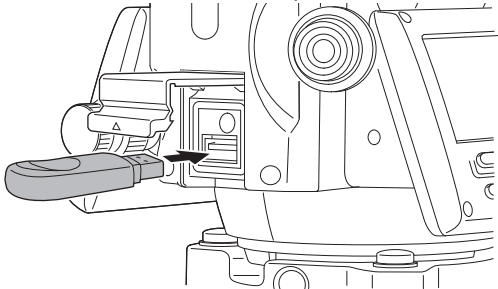

- When using a USB memory with 4 metal terminals on the surface, insert it with the terminal facing backwards to avoid damaging the USB port.

● **PROCEDURE Removing USB Flash Drive**

- 1 Remove the USB flash drive from the USB port.
- 2 Close the external interface hatch until a click is heard.



- It is recommended that you remove the USB flash drive after you finish inputting/outputting data and then return to the MEMORY MGR. Menu or TOP FIELD Menu.

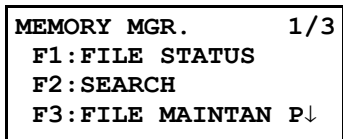

MEMORY MGR. Menu

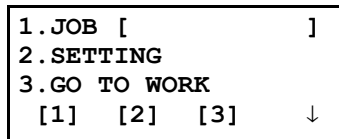

TOP FIELD

If you remove the USB flash drive before returning to the above menus, the following display may be displayed when you insert it to your PC. Select "Scan and fix" to avoid this screen is displayed again.

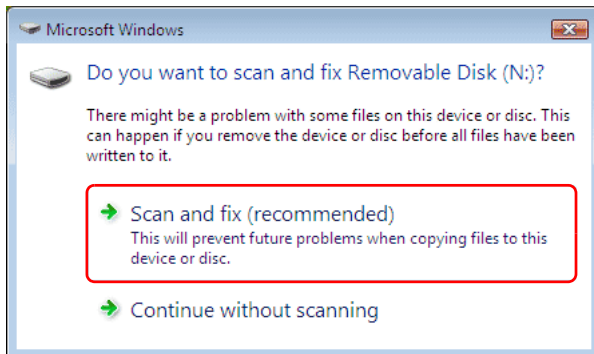

- Removing the USB flash drive before returning to the above menus itself will never damage the measurement data in the memory.

16 DETACH/ATTACH OF TRIBRACH

The instrument is easily detached or attached to the tribrach, with a tribrach locking lever loosened or tightened for this purpose.

● Detachment

- 1 Loosen the tribrach locking lever, by revolving it 180° or 200 gon in the counterclockwise direction (which will point the triangle mark upwards).
- 2 Grip the carrying handle firmly with one hand while holding the tribrach with the other. Then lift the instrument straight upwards and off.

● Attachment

- 1 Hold the instrument by the carrying handle, with one hand, and carefully lower it on top of the tribrach while, at the same time, coinciding the alignment piece with the tribrach alignment groove on the instrument and tribrach respectively.
- 2 When fully seated, revolve the tribrach locking lever 180° or 200 gon clockwise (which will point the triangle mark downwards again).
- 3 Confirm that the upper instrument section is securely attached.

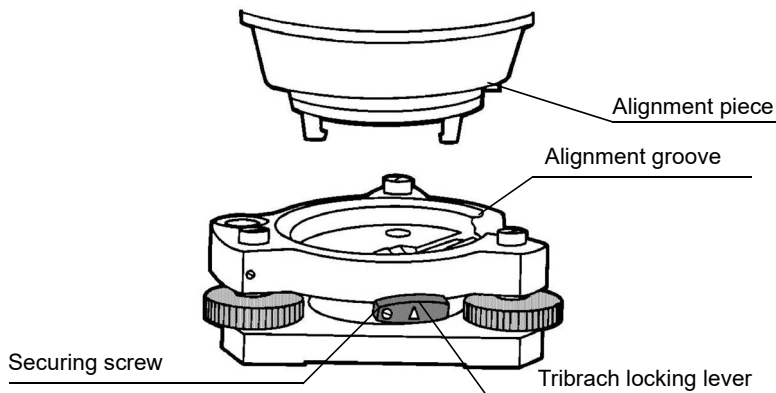

● Locking the Tribrach Locking Lever

The tribrach locking lever can be locked, to prevent it be accidentally removed, especially if the upper instrument section is not being detached very often. Simply tighten the securing screw on the locking lever with the accessory precision screwdriver, found in the case.

17 SELECTING MODE

17.1 Items of the Selecting Mode

The following modes are available.

Menu	Items	Selecting item	Display
1: UNIT SET	TEMP. & PRES.	°C/°F hPa / mmHg /inHg	Select the unit of temperature for atmospheric correction. Select the unit of air pressure for atmospheric correction.
	ANGLE	DEG (360°)/ GON (400 G)/ MIL (6400 M)	Choose degree, gon or mil unit for measuring angle.
	DISTANCE	m/ft/ft + in	Choose measuring unit for distance meter, feet or feet and inch
	FEET	US SURVEY/ INTERNATIONAL	Select the meter / feet conversion factor. US SURVEY feet 1 m = 3.280833333333333 ft. INTERNATIONAL feet 1 m = 3.280839895013123 ft.
2: MODE SET	POWER ON MODE	ANGLE MEAS./ DISTANCE MEAS.	Select to set the measurement mode for angle or distance when the power is turned on.
	FINE/CRS/ TRK	FINE/COARSE/ TRACK	Select Fine /Coarse / Tracking mode in distance measurement mode, when the power is turned on.
	HD&VD/SD	HD&VD/SD	Specify which is displayed first, horizontal and vertical distance or slope distance, when the power is turned on.
	V ANGLE Z0/H0	ZENITH 0/ HORIZONTAL 0	Choose the vertical angle reading from zenith or from level.
	N-TIMES / REPEAT	N-TIMES/REPEAT	Select the measurement mode for distance when the power is turned on.
	TIMES OF MEAS.	0 to 99	Set N (number of times) for times of distance measurement. When setting number of times as 1 or 0, it is single measurement.
	NEZ / ENZ	NEZ/ENZ	Select a coordinate displaying order either NEZ or ENZ.
	HA MEMORY	ON/OFF	Horizontal angle set can be retained after the power is turned off.
	ESC KEY MODE	DATA COLLECT/ LAYOUT/REC *1/ OFF	You can select a function of the {ESC} key. DATA COLLECT/LAYOUT: It is possible to enter data input mode (in DATA COLLECT) or Layout Menu from normal measuring mode directly. REC: While executing normal or offset measuring, the measuring data can be output. OFF: Returns to normal function.
	COORD. CHECK	ON/OFF	Select coordinate displaying ON or OFF when setting a point.
FINE READING	0.1 mm/1 mm	Select 1 mm or 0.1 mm for the minimum reading unit in the distance mode (FINE mode).	

	OFFSET V ANG	FREE/HOLD	Select Vertical angle setting in the Angle Offset measurement mode. FREE: Vertical angle varies by the angle of the telescope. HOLD: Vertical angle is fixed even if the angle of the telescope changes.
	NON-PSM / PRISM	NON-PRISM/PRISM /SHEET	Select the distance measurement mode when the power is turned ON.
3: OTHERS SET	H-ANGLE BUZZER	ON/OFF	Specify whether the buzzer sounds or not for every horizontal angle 90°.
	S/A BUZZER	ON/OFF	Specify whether the buzzer sounds or not in the set audio mode.
	W-CORRECTION	OFF/0.14/0.20	Set correction for refraction and earth curvature, coefficient of refraction as; K=0.14, K=0.20 or no correction.
	NEZ MEMORY	ON/OFF	It is possible to retain the coordinate of instrument point, the instrument height and prism height after power off.
	REC TYPE *1	REC-A/REC-B	Select REC-A or REC-B for data output. REC-A : The measurement is made again and this new data is output. REC-B : The data being displayed is output.
	CR,LF *1	ON/OFF	It is possible to output the data with carriage return and line feed.
	NEZ REC FORM	STANDARD/ with RAW/ STANDARD -12Dig/ with RAW - 12Dig	Select to record coordinates in standard or with raw data.
	MANUAL NEZ REC	ON/OFF	In the layout mode or data collect mode, it is possible to record coordinates entered directly from the keyboard.
	ACK MODE *1	STANDARD/ OMITTED	Set the procedure of the communication with external device. STANDARD:Normal procedure OMITTED: Even though the [ACK] is omitted from the external device, the data is not sent again.
	GRID FACTOR	USE G.F./ DON'T USE	Select using GRID FACTOR in calculation of measurement data.
	CUT & FILL	STANDARD/ CUT&FILL	In the layout mode, CUT & FILL can be displayed instead of dZ.
	CONTRAST MENU	ON/OFF	When the instrument is turned ON, it is possible to display the screen which you can adjust contrast of the display and confirm the prism constant (PSM), non-prism constant (NPM), sheet constant (SHT) and atmospheric correction value (PPM).
	PASSWORD *2	ON/OFF	When the instrument is turned ON, the screen to request the password will appear. *3

*1 Available only for *Bluetooth* function built-in models.

*2 Applicable only to the instruments with security function

*3 If you forget a password, the instrument needs repair to cancel the password. Please contact Topcon or your local Topcon dealer.

17.2 How to Set Selecting Mode

<Example>: Setting unit in hPa, °F, NEZ MEMORY:ON

Operating procedure	Operation	Display
1 After pressing the {MENU} key, press the {F4} (P↓) key twice to get the menu on page 3.	{MENU} {F4} {F4}	MENU 3/4 F1: ILLUMINATION F2: PARAMETERS 1 F3: PARAMETERS 2 P↓
2 Press the {F3} key.	{F3}	PARAMETERS 2 F1: UNIT SET F2: MODE SET F3: OTHERS SET
3 Press {F1} (UNIT SET) key.	{F1}	UNIT SET 1/2 F1: TEMP. & PRES. F2: ANGLE F3: DISTANCE P↓
4 Press {F1} (TEMP. & PRES.) key.	{F1}	TEMP. & PRES. UNIT TEMP. : °C PRES. : mmHg °C °F --- ENTER
5 Press {F2} (°F) key, and press {F4} (ENTER) key.	{F2} {F4}	TEMP. & PRES. UNIT TEMP. : °F PRES. : mmHg hPa mmHg inHg ENTER
6 Press {F1} (hPa) key, and press {F4} (ENTER) key. Returns to unit set menu.	{F1} {F4}	UNIT SET 1/2 F1: TEMP. & PRES. F2: ANGLE F3: DISTANCE
7 Press {ESC} key. Returns to PARAMETERS 2 menu.	{ESC}	PARAMETERS 2 F1: UNIT SET F2: MODE SET F3: OTHERS SET
8 Press {F3} (OTHERS SET) key.	{F3}	OTHERS SET 1/5 F1: H-ANGLE BUZZER F2: S/A BUZZER F3: W-CORRECTION P↓
9 Press {F4} (P↓) key, to get the function in page 2.	{F4}	OTHERS SET 2/5 F1: NEZ MEMORY F2: REC TYPE F3: CR, LF P↓

10 Press {F1} key.	{F1}	<table border="1"> <tr> <td>NEZ MEMORY</td> <td>[OFF]</td> </tr> <tr> <td>[ON] [OFF] ---</td> <td>ENTER</td> </tr> </table>	NEZ MEMORY	[OFF]	[ON] [OFF] ---	ENTER				
NEZ MEMORY	[OFF]									
[ON] [OFF] ---	ENTER									
11 Press {F1} (ON) key, and press {F4} (ENTER) key. Returns to OTHERS SET menu.	{F1} {F4}	<table border="1"> <tr> <td>OTHERS SET</td> <td>2/5</td> </tr> <tr> <td>F1:NEZ MEMORY</td> <td></td> </tr> <tr> <td>F2:REC TYPE</td> <td></td> </tr> <tr> <td>F3:CR,LF</td> <td>P↓</td> </tr> </table>	OTHERS SET	2/5	F1:NEZ MEMORY		F2:REC TYPE		F3:CR,LF	P↓
OTHERS SET	2/5									
F1:NEZ MEMORY										
F2:REC TYPE										
F3:CR,LF	P↓									

18 CHECKS AND ADJUSTMENTS

A GM is a precision instrument that requires fine adjustments. It must be inspected and adjusted before use so that it always performs accurate measurements.

- Always perform checking and adjustment in the proper sequence beginning from Section 18.1 "Circular Level" to 18.7 "Checking and Adjusting of Laser Plummet*1".
- In addition, the instrument should be inspected with special care after it has been stored a long time, transported, or when it may have been damaged by a strong shock.
- Make sure the instrument is securely set up and stable before performing checks and adjustments.

18.1 Circular Level



- Be careful that the tightening tension is identical for all the adjusting screws. Also, do not over-tighten the adjusting screws as this may damage the circular level.

● PROCEDURE: Checking and adjusting

- 1 Level while checking the display.
☞ see Section 2.5.2 "Levelling".



- If the tilt sensor is misaligned, the circular level is not adjusted correctly.
- 2 Check the position of the bubble of the circular level.
If the bubble is not off-center, no adjustment is necessary.
If the bubble is off-center, perform the following adjustment.
 - 3 First confirm the off-center direction.
Use the hexagonal wrench (2.5 mm) to loosen the circular level adjustment screw on the side opposite to the direction the bubble is displaced to move the bubble to the center.
 - 4 Adjust the adjusting screws until the tightening tension of the three screws is the same to align the bubble in the middle of the circle.

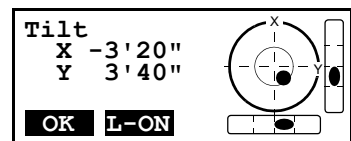

Circular level
adjusting screws

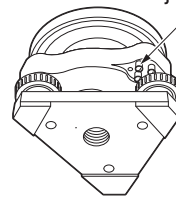

18.2 Adjustment of Vertical Angle 0 Datum

If when measuring the vertical angle of target A at telescope position normal (direct) and reverse settings, the amount of normal and reverse measurements combined is other than 360° (ZENITH-0), half of the difference from 360° is the error amount from corrected 0 setting. Carry out adjustment. As adjustment for vertical angle 0 setting is the criteria for determining instrument coordinate origin, use special care for adjustment.

Operating procedure	Operation	Display
1 Carefully level the instrument checking the screen. Turn OFF the power.		
2 Power ON the instrument.	Power ON	
3 After pressing the {MENU} key, press the {F4} (P↓) key three times to get the menu on page 4	{MENU} {F4} {F4} {F4}	MENU 4 / 4 F1:ADJUSTMENT MODE F2:CONTRAST ADJ. F3:STATUS SCREEN P↓
4 Press the {F1} key.	{F1}	ADJUSTMENT MODE F1:V ANGLE 0 POINT F2:V0 AXIS P↓
5 Press the {F1} key.	{F1}	V0 ADJUSTMENT <STEP-1> FRONT V: 90°00'00" ENTER
6 Collimate target A from the telescope properly in normal setting.	Collimate A (Normal)	
7 Press the {F4} (ENTER) key.	{F4}	V0 ADJUSTMENT <STEP-2> REVERSE V: 270°00'00" ENTER
8 Collimate target A in reverse telescope setting.	Collimate A (Reverse)	
9 Press the {F4} (ENTER) key. Measured value is set and carry out normal angle measurement.	{F4}	<SET!> ↓ V : 270°00'00" HR: 120°30'40" OSET HOLD HSET P1↓
10 Check that the total amount of normal and reverse angular travel is 360° collimating the target A by normal and reverse positions.		

18.3 Adjustment of Compensation Systematic Error of Instrument

- 1 Vertical axis error
- 2 Collimation axis error
- 3 Vertical angle 0 datum error

Correction constants for the above errors are calculated and stored in the instrument by the following procedure, and then measurement values are corrected using the stored constants. This adjustment has a direct effect on determining the coordinate origin. Carry out the adjustment very carefully.

Operating procedure	Operation	Display
1 Carefully level the instrument checking the screen. Turn OFF the power.		
2 Power ON the instrument.	Power ON	
3 After pressing the {MENU} key, press the {F4} (P↓) key three times to get the menu on page 4	{MENU} {F4} {F4} {F4}	MENU 4 / 4 F1: ADJUSTMENT MODE F2: CONTRAST ADJ. F3: STATUS SCREEN P↓
4 Press the {F1} key.	{F1}	ADJUSTMENT MODE F1: V ANGLE 0 POINT F2: V0 AXIS P↓
5 Press the {F2} key.	{F2}	V0 AXIS F1: MEASUREMENT F2: CONSTANT LIST
6 Press the {F1} key.	{F1}	V0/AXIS ADJUSTMENTS ↓ (A) COLLIMATION ↓
7 Collimate target A. (FACE (1)).	Collimate A (Normal)	FRONT FACE1 /0 V: 89°55'50" LEVEL ±0 SET
8 Press the {F4} (SET) key. *1 The sample display shows that the measurement is made 5 times in FACE 1.	{F4}	
9 Turn the telescope in reverse telescope setting (FACE (2)).	Turn telescope	
10 Collimate target A.	Collimate A (Reverse)	REVERSE FACE2 /5 V: 270°04'20" LEVEL ±0 SET ↓

<p>11 Press the {F4} (SET) key. Repeat the procedures in step 8 and 9 so that the count of measured times matches to the one in FACE (1). *2)</p>	<p>{F4}</p>	<p style="text-align: center;">COMPLETE</p>
<ul style="list-style-type: none"> To show the constant list of systematic error of instrument 		<p>ADJUSTMENT MODE F1:V ANGLE 0 POINT F2:V0 AXIS</p>
<p>1 Press the {F2} key from Adjustment Mode menu.</p>	<p>{F2}</p>	<p>V0 AXIS F1:MEASUREMENT F2:CONSTANT LIST</p>
<p>2 Press the {F2} key. Correction values are displayed.</p>		<p>{F2}</p>
<p>3 Press the {F1} key. The display returns to previous menu.</p>	<p>{F1}</p>	
<p>*1) It is able to get the average value from 1 to 10 measurements. To get the average, repeat the procedures in steps 5, 6 or 8, 9. The measured times is counted in the second line of display. *2) The compensation values of 1) Error of vertical axis (X,Y tilt sensor offset), 2) Collimation error, and 3) Error of vertical angle 0datum will be set and memorized internally.</p>		

18.4 Reticle

With this option you can check the perpendicularity of the reticle and the horizontal/vertical positions of reticle lines.

● Check 1: Perpendicularity of the reticle to the horizontal axis

- 1) Carefully level the instrument.
- 2) Align a clearly visible target (the edge of a roof for example) on point A of the reticle line.

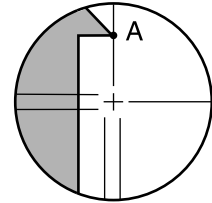

- 3) Use the telescope fine motion screw to align the target to point B on a vertical line.
If the target moves parallel to the vertical line, adjustment is unnecessary. If its movement deviates from the vertical line, have our service representative adjust it.

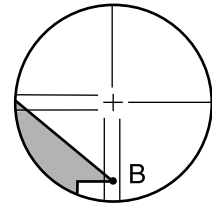

● Check 2: Vertical and horizontal reticle line positions



- Perform check in weak sunlight and no scintillation.
- "TILT" should be set to "XY-ON" and "ERROR CORRECTION" to "ON" in <PARAMETERS 1> while performing checks.
☞ see Section 6.4 "Setting Mode 1".

- 1) Carefully level the instrument.
- 2) Install a target at a point about 100 m in the horizontal direction from the instrument.
- 3) While the observation screen is displayed and the telescope is in Face 1, sight the center of the target correctly and read out the horizontal angle A1 and the vertical angle B1.



Example:

Horizontal angle A1 = 18° 34' 00"
Vertical angle B1 = 90° 30' 20"

- 4) While the telescope is in Face 2, sight the center of the target correctly and read out the horizontal angle A2 and the vertical angle B2.

Example:

Horizontal angle A2 = 198° 34' 20"
Vertical angle B2 = 269° 30' 00"

- 5) Do the calculations:
 A2-A1 and B2+B1
 If A2-A1 is within $180^\circ \pm 20''$ and B2(B1 is within $360^\circ \pm 40''$,
 adjustment is unnecessary.

Example:

$$\begin{aligned} \text{A2-A1 (Horizontal angle)} &= 198^\circ 34' 20'' - 18^\circ 34' 00'' \\ &= 180^\circ 00' 20'' \end{aligned}$$

$$\begin{aligned} \text{B2-B1 (Vertical angle)} &= 269^\circ 30' 00'' + 90^\circ 30' 20'' \\ &= 360^\circ 00' 20'' \end{aligned}$$

If the difference is large even after repeating the check 2 or 3 times, make sure that checking and adjusting of Section 18.2 "Adjustment of Vertical Angle 0 Datum" and 18.3 "Adjustment of Compensation Systematic Error of Instrument" are completed.

If the results remain the same, have our service representative perform the adjustment.

18.5 Optical Plummet



- Be careful that the tightening tension is identical for all the adjusting screws. Also, do not over-tighten the adjusting screws as this may damage the circular level.

● Checking

- 1) Carefully level the instrument and center a survey point precisely in the reticle of the optical plummet.
- 2) Turn the upper part through 180° and check the position of the survey point in the reticle.
 If the surveying point is still centered, no adjustment is necessary.
 If the survey point is no longer centered in the optical plummet, perform the following adjustment.

● Adjusting

- 3) Correct half the deviation with the levelling foot screw.

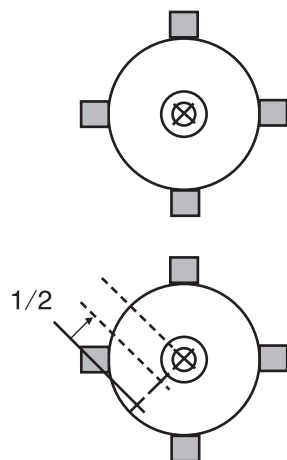

- 4) Remove the optical plummet reticle cover.

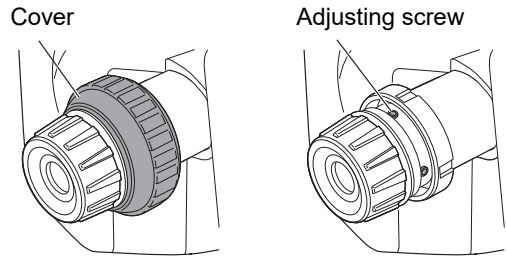

- 5) Turn the 4 adjusting screws of the optical plummet to adjust the remaining half of the deviation using hexagonal wrench (1.3 mm) as shown below.

When the survey point is on the lower (upper) part of the illustration:

Loosen the upper (lower) adjusting screw slightly, and tighten the upper (lower) adjusting screw the same amount to move the survey point to a point directly under the center of the optical plummet.

(It will move to the line in the figure on the right.)

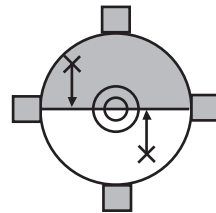

If the survey point is on the solid line (dotted line):

Loosen the right (left) adjusting screw slightly and, tighten the left (right) adjusting screw by the same amount to move the survey point to a point in the center of the optical plummet.

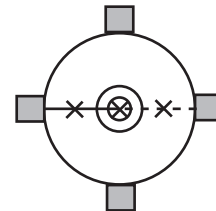

- 6) Check to make sure that the survey point remains centered on the reticle even if the upper part of the instrument is rotated.

If necessary, perform the adjustment again.

- 7) Replace the optical plummet reticle cover by matching the grooves on the cover with the grooves on the optical plummet.

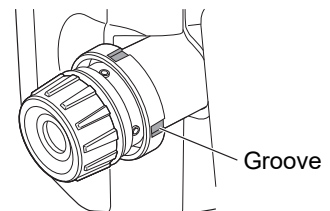

18.6 Additive Distance Constant

The additive distance constant K of the GM is adjusted to 0 before delivery. Although it almost never deviates, use a baseline with a known distance precision to check that the additive distance constant K is close to 0 several times a year and whenever the values measured by the instrument begin to deviate by a consistent amount. Perform these checks as follows.



- Errors in setting up the instrument and reflective prism or in sighting the target will influence the additive distance constant. Be extremely careful to prevent such errors when performing these procedures.
- Set up so that the instrument height and the target height are identical. If a flat place is not available, use an automatic level to make sure the heights are identical.

● **Checking**

- 1) Find an area of flat ground where two points 100 m apart can be selected.
Set up the Instrument at point A and the reflective prism at point B. Establish a point C half way between points A and B.
- 2) Precisely measure the horizontal distance between point A and point B 10 times and calculate the average value.
- 3) Place the GM at point C directly between points A and B and set up the reflective prism at point A.
- 4) Precisely measure the horizontal distances CA and CB 10 times each and calculate the average value for each distance.
- 5) Calculate the additive distance constant K as follows.
 $K = AB - (CA + CB)$
- 6) Repeat steps 1 to 5 two or three times.
If the additive distance constant K is within ± 3 mm even once, adjustment is unnecessary.
If it always exceeds this range, have our service representative perform an adjustment.

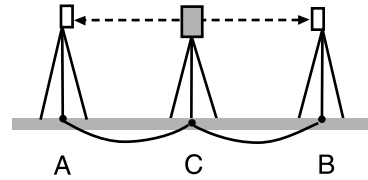
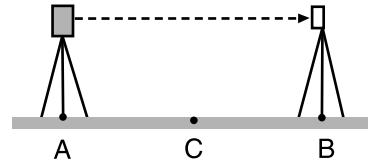

18.7 Checking and Adjusting of Laser Plummet*1

Checks and adjustments are performed using an adjustment target. Make an enlarged or reduced copy of the figure below.

*1: Laser plummet is available as a factory option depending on the country or the area where the instrument is purchased.

● **Checking**

- 1) Set the tripod so that the height from the ground to the tripod head is approximately 1.3 m, level the instrument, and emit the laser plummet beam.
 see Section 2.5.2 "Levelling".
- 2) Rotate the upper part horizontally and place a target so that it is aligned with the center of the circle created by the rotating laser plummet beam.
 - Laser beam remains centered on the center of the target – No adjustment necessary
 - Laser beam strays from the center of the target – Adjustment necessary.
 - Laser beam draws a circle outside the target circle – Contact your local dealer.

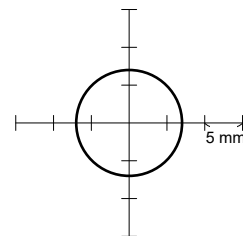

● **Adjusting**

- 1) Turn the laser plummet adjustment cap anticlockwise and remove.

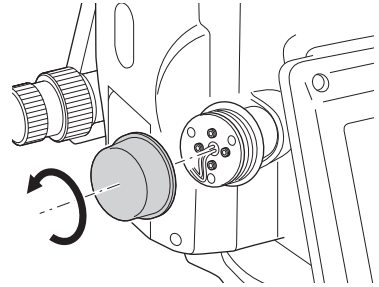

- 2) Emit the laser plummet beam.
- 3) Note the current position (x) of the laser beam.
- 4) Turn the upper part of the instrument horizontally through 180° and note the new position (y) of the laser beam. Adjustment will bring the laser beam to a point midway along a line drawn between these two positions.
- 5) Check the position of the desired final position. Place a target so that its center is aligned with the desired final position. The remaining deviation will be adjusted using the 4 fine adjustment screws.

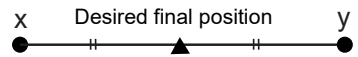

- Be extremely careful to adjust all the fine adjustment screws by the same amount so that none will be over-tightened.
- Turn screws clockwise to tighten.

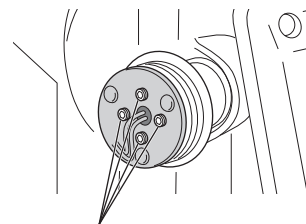
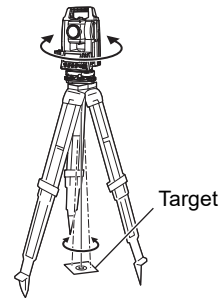

- 6) When the laser beam is on the upper (lower) part of Fig. A the up/down adjustment is made as follows:
 - a. Insert the provided hexagon key wrench into both the upper and lower screws.

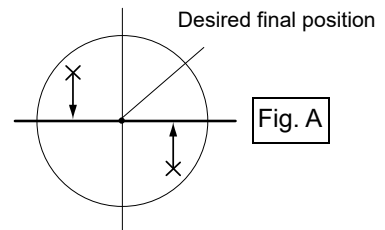

- b. Slightly loosen the upper (lower) screw and tighten the lower (upper) screw. Make sure that the tightening tension for both screws is identical. Continue to adjust until the laser beam is on the horizontal line of the target.

- 7) When the laser beam is in the right (left) part of Fig. B the left (right) adjustment is made as follows:
- Insert a hexagon key wrench into both the left and right screws.
 - Slightly loosen the right (left) screw and tighten the left (right) screw. Make sure that the tightening tension for both screws is identical. Continue to adjust until the laser beam is aligned with the target center.

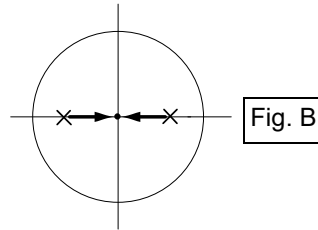

- Turn the upper part of the instrument horizontally and check that the laser beam is now aligned with the target center.
- Re-attach the laser plummet adjustment cap.

Note

- Tightening each of the fine adjustment screws moves the laser plummet beam in the directions shown below.

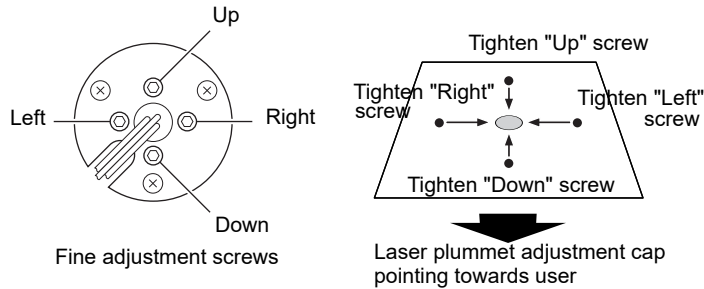

19 TOP FIELD MODE

19.1 MAIN MENU (Major Functions)

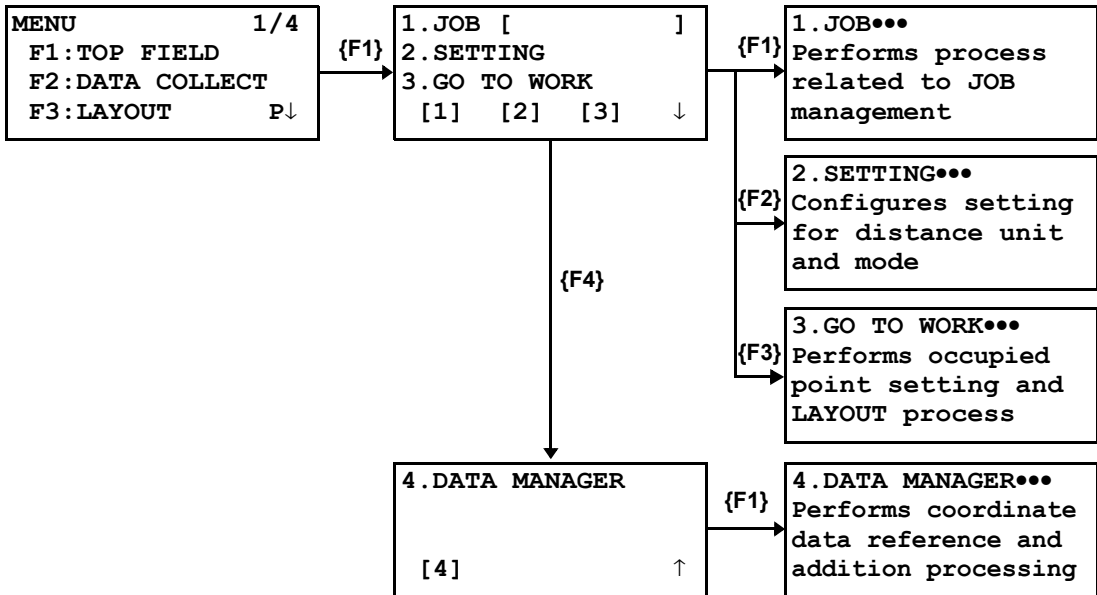

19.2 JOB



- When a job is created, a measurement/coordinates data file with the same job name will be created in the internal memory. If there is another file with the same name, the existing data file will be used for the job.

19.2.1 To Create New Job

Operating procedure	Operation	Display
1 Select {F1} (TOP FIELD) from the menu.	{MENU} {F1}	1. JOB [] 2. SETTING 3. GO TO WORK [1] [2] [3] ↓
2 Select {F1} (JOB).	{F1}	1. OPEN JOB FILE 2. CREATE NEW JOB 3. NO JOB FILE [1] [2] [3] ↓
3 Select {F2} (CREATE NEW JOB).	{F2}	ENTER JOB FILE [_] ALP CLR
4 Enter job name. ● 10 letters maximum	Enter job name	ENTER JOB FILE [JOB1 _] ALP CLR
5 Press {ENT} key to create a new job. ● If there is another job with the same name, the existing job will be selected. ● A maximum of 49 job files can be registered.	{ENT}	1. JOB [JOB1] 2. SETTING 3. GO TO WORK [1] [2] [3] ↓

19.2.2 To Select Existing Job

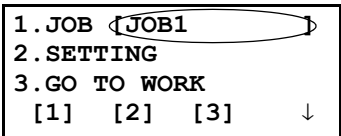
Operating procedure	Operation	Display
1 Select {F1} (TOP FIELD) from the menu.	{MENU} {F1}	<pre> 1 . JOB [] 2 . SETTING 3 . GO TO WORK [1] [2] [3] ↓ </pre>
2 Select {F1} (JOB).	{F1}	<pre> 1 . OPEN JOB FILE 2 . CREATE NEW JOB 3 . NO JOB FILE [1] [2] [3] ↓ </pre>
3 Select {F1} (OPEN JOB FILE).	{F1}	<pre> SELECT JOB FILE [_] ↑ ↓ ALP CLR </pre>
4 Select an existing job name with {F1} or {F2} (Arrow) key, or enter a job name.	{F1} or {F2} Enter job name	<pre> SELECT JOB FILE [JOB1_] ↑ ↓ ALP CLR </pre>
5 Press {ENT} key to select job.	{ENT}	<pre> 1 . JOB [JOB1] 2 . SETTING 3 . GO TO WORK [1] [2] [3] ↓ </pre>
<ul style="list-style-type: none"> When the job is selected, the job name will be displayed at the top right of TOP FIELD of the main menu. 		
 <pre> 1 . JOB [JOB1] 2 . SETTING 3 . GO TO WORK [1] [2] [3] ↓ </pre>		

19.2.3 To Delete Job

Operating procedure	Operation	Display
1 Select {F1} (TOP FIELD) from the menu.	{MENU} {F1}	<pre> 1 . JOB [] 2 . SETTING 3 . GO TO WORK [1] [2] [3] ↓ </pre>
2 Select {F1} (JOB).	{F1} , {F4}	<pre> 4 . DELETE JOB FILE [4] ↓ </pre>
3 Select {F4} (↓) to move to the second page of the JOB menu.		<pre> SELECT JOB TO DEL [_] ↑ ↓ ALP CLR </pre>
4 Select {F1} (DELETE JOB FILE).	{F1}	

<p>5 Select an existing job name with {F1} or {F2} (Arrow) key, or enter a job name.</p>	<p>Enter/ Select job name</p>	<pre>SELECT JOB TO DEL [JOB1_] ↑ ↓ ALP CLR</pre>
<p>6 Press {ENT} key.</p>	<p>{ENT}</p>	<pre>SELECT JOB TO DEL [JOB1_] >OK ? [YES] [NO]</pre>
<p>7 Pressing {F3} (YES) key will delete the job file.</p>	<p>{F3}</p>	<pre>4 .DELETE JOB FILE [4] ↓</pre>

19.2.4 When Job is not to be Used

Job selection can be canceled if the job is not to be used and coordinate data is not to be recorded.

Operating procedure	Operation	Display
<p>1 Select {F1} (TOP FIELD) from the menu.</p>	<p>{MENU} {F1}</p>	<pre>1 .JOB [JOB1] 2 .SETTING 3 .GO TO WORK [1] [2] [3] ↓</pre>
<p>2 Select {F1} (JOB).</p>	<p>{F1}</p>	<pre>1 .OPEN JOB FILE 2 .CREATE NEW JOB 3 .NO JOB FILE [1] [2] [3] ↓</pre>
<p>3 Job selection will be cancelled when {F3} (NO JOB FILE) is selected.</p>	<p>{F3}</p>	<p><SET!></p>

19.3 SETTING

Operating procedure	Operation	Display
<p>1 Select {F1} (TOP FIELD) from the menu.</p>	<p>{MENU} {F1}</p>	<pre>1 .JOB [] 2 .SETTING 3 .GO TO WORK [1] [2] [3] ↓</pre>
<p>2 Select {F2} (SETTING).</p>	<p>{F2}</p>	<pre>DIST UNITS : FT-10 COORDINATES : XYZ EDM MODE : FINE OK EDIT</pre>
<p>3 To change the setting, select {F2} (EDIT). ● To not change the setting, select {F1} (OK).</p>	<p>{F2}</p>	<pre>1 .US FEET-10THE 2 .US FEET-INCHES 3 .METERS [1] [2] [3]</pre>

<p>4 Select {F1} to {F3} to set the unit of distance.</p> <p>{F1} (US FEET-10THE): Display in feet {F2} (US FEET-INCHES): Display in feet and inches {F3} (METERS): Display in meters</p>	<p>Select {F1} ~ {F3}</p>	<pre>1 . N , E , Z 2 . E , N , Z 3 . X , Y , Z [1] [2] [3]</pre>
<p>5 Select {F1} to {F3} to set the display sequence of coordinates.</p> <p>{F1} (N,E,Z): Display N, E, Z {F2} (E,N,Z): Display E, N, Z {F3} (X,Y,Z): Display X, Y, Z</p>	<p>Select {F1} ~ {F3}</p>	<pre>1 . FINE 2 . CRS-1mm 3 . CRS-10mm [1] [2] [3]</pre>
<p>6 Select {F1} ~ {F3} to set the distance measurement mode.</p> <p>{F1} (FINE): FINE mode {F2} (CRS-1 mm): COARSE mode (Rounding in the unit of 1 mm) {F3} (CRS-10 mm): COARSE mode (Rounding in the unit of 10 mm)</p>	<p>Select {F1} ~ {F3}</p>	<pre>DIST UNITS : METERS COORDINATES : NEZ EDM MODE : CRS-10 OK EDIT</pre>
<p>7 Press {F1} (OK) to set.</p>	<p>{F1}</p>	<pre>1 . JOB [] 2 . SETTING 3 . GO TO WORK [1] [2] [3] ↓</pre>

19.4 GO TO WORK

The following operations are performed with GO TO WORK.

- 1) Setting of occupied point and backsight ●●●●●INST SETUP
- 2) Layout ●●●●●LAYOUT
- 3) Ordinary measuring and coordinate saving ●●●●●TOPO

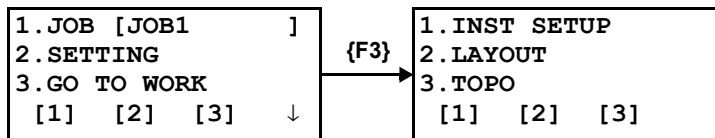

19.4.1 To Set Occupied Point and Backsight

To set occupied point

- **Selecting from existing coordinate data**

Operating procedure	Operation	Display
<p>1 Select {F1} (INST SETUP).</p>	<p>{F1}</p>	<pre>1 . INST SETUP 2 . LAYOUT 3 . TOPO [1] [2] [3]</pre> <hr/> <pre>1 . SELECT INST PT 2 . CREATE INST PT 3 . MEAS KNWN PTS [1] [2] [3]</pre>

<p>2 Select {F1} (SELECT INST PT).</p>	<p>{F1}</p>	<pre> ENTER INST PT PT#: [] ↑ ↓ ALP CLR </pre>
<p>3 Select an existing coordinate point with {F1} or {F2} (Arrow) key, or directly enter a coordinate point.</p>	<p>Enter/ Select PT#</p>	<pre> ENTER INST PT PT#: [OCC-PT] ↑ ↓ ALP CLR </pre>
<p>4 Set with {ENT} key.</p>	<p>{ENT}</p>	<pre> ENTER INST HT INST HT =0.000_ m CLR </pre>
<p>5 Enter an instrument height.</p>	<p>Enter instrument height</p>	<pre> ENTER INST HT INST HT =1.500_ m CLR </pre>
<p>6 Set with {ENT} key.</p> <ul style="list-style-type: none"> Then, the procedure will move onto backsight setting. 	<p>{ENT}</p>	<pre> 1.SELECT BS PT 2.CREATE BS PT 3.BS DIRECTION [1] [2] [3] </pre>

● **Setting by entering the coordinate data of a occupied point directly**

Operating procedure	Operation	Display
<p>1 Select {F1} (INST SETUP).</p>	<p>{F1}</p>	<pre> 1.INST SETUP 2.LAYOUT 3.TOPO [1] [2] [3] </pre>
<p>2 Select {F2} (CREATE INST PT).</p>	<p>{F2}</p>	<pre> 1.SELECT INST PT 2.CREATE INST PT 3.MEAS KNWN PTS [1] [2] [3] </pre>
<p>3 Enter the coordinate point of a occupied point and its description.</p>	<p>Enter PT#, Enter DESC</p>	<pre> ENTER NEW POINT: PT#: [_] DESC: [_] ALP CLR </pre>
<p>4 Set with {ENT} key.</p>	<p>{ENT}</p>	<pre> ENTER NEW POINT: PT#: [OCC] DESC: [POINT_] ALP CLR </pre>
		<pre> N [] E [] Z [] CLR </pre>

5	Enter occupied point coordinates (N, E, Z).	Enter occupied point coordinate	<pre>N [0.000] E [0.000] Z [0.000] CLR</pre>
6	Set with {ENT} key.	{ENT}	<pre>ENTER INST HT INST HT =0.000_ m CLR</pre>
7	Enter an instrument height.	Enter instrument height	<pre>ENTER INST HT INST HT =1.500_ m CLR</pre>
8	Set with {ENT} key.	{ENT}	<pre>1.SELECT BS PT 2.CREATE BS PT 3.BS DIRECTION [1] [2] [3]</pre>
<ul style="list-style-type: none"> Then, the procedure will move onto backsight setting. 			

● Seeking an occupied point from existing coordinate data

Operating procedure	Operation	Display	
1	Select {F1} (INST SETUP).	{F1}	<pre>1.INST SETUP 2.LAYOUT 3.TOPO [1] [2] [3]</pre>
2	Select {F3} (MEAS KNWN PTS).	{F3}	<pre>1.SELECT INST PT 2.CREATE INST PT 3.MEAS KNWN PTS [1] [2] [3]</pre>
3	Enter an instrument height.	Enter instrument height	<pre>ENTER INST HT INST HT =0.000_ m CLR</pre>
4	Set with {ENT} key.	{ENT}	<pre>ENTER INST HT INST HT =1.500_ m CLR</pre>
4	Set with {ENT} key.	{ENT}	<pre>ENTER # REF PTS # REF PTS: = CLR</pre>
5	Enter point number to collimate. ● Collimate point number: 2 to 7 points	Enter collimate point number	<pre>ENTER # REF PTS # REF PTS: = 2 CLR</pre>
6	Set with {ENT}.	{ENT}	<pre>ENTER TARGET HT HT OF ROD =0.000_ m CLR</pre>

7 Enter a reflector height.

Enter reflector height

```

ENTER TARGET HT
HT OF ROD
      =1.500_   m
                        CLR
    
```

8 Set with {ENT} key.

{ENT}

```

ENTER TARGET PT# 1/2
PT#:  [ _      ]
      ↑   ↓   ALP CLR
    
```

9 Select the coordinate point of a collimate point with {F1} or {F2} (Arrow) key, or enter the coordinate point directly. *1)

Enter/ Select PT#

```

ENTER TARGET PT# 1/2
PT#:  [PT-01_  ]
      ↑   ↓   ALP CLR
    
```

10 Set with {ENT} key.

{ENT}

```

MEAS POINT          1/2
PT#:  [PT-01      ]
HD:           m
MSR  CHK   HR
    
```

11 Collimate prism and press {F1} (MSR) key. Begin measurement.

{F1}

```

MEAS POINT          1/2
PT#:  [PT-01      ]
HD*           <<< m
>Measuring...
    
```

12 When the prism measurement is completed, perform measurement for the next collimate point.

- Follow the same procedure.

```

ENTER TARGET PT# 2/2
PT#:  [PT-01_  ]
      ↑   ↓   ALP CLR
    
```

↓

```

MEAS POINT          2/2
PT#:  [PT-01      ]
HD*           <<< m
>Measuring...
    
```

After the prism is measured the set number of times, the occupied point coordinates will be calculated and the standard deviation will be displayed.

```

dN:    0000.00 mm
dE:    0000.00 mm
dZ:    0000.00 mm
OK                      NO
    
```

13 Press {F1} (OK).

The screen for inputting the coordinate point of an occupied point and its description will be displayed.

{F1}

```

ENTER NEW POINT:
PT#:  [ _      ]
DESC: [      ]
                        ALP CLR
    
```

14 Enter the coordinate point of an occupied point and its description.

Enter PT#, Enter DESC

```

ENTER NEW POINT:
PT#:  [OCC      ]
DESC: [POINT_  ]
                        ALP CLR
    
```

<p>15 Set with {ENT} key.</p>	<p>{ENT}</p>	<pre>POINT X SET! ORIENTATION SET! OK NEZ</pre>
<p>16 When you press {F1} (OK), an occupied point and backsight will be set and the procedure will be completed.</p> <ul style="list-style-type: none"> The backsight is set up based on the previously collimated prism position. Therefore, always press {OK} under the condition in which the previous prism backsight collimated. 	<p>{F1}</p>	<pre>1. INST SETUP 2. LAYOUT 3. TOPO [1] [2] [3]</pre>

● **Checking collimate point coordinates during prism collimation**

Operating procedure	Operation	Display
<p>1 To check the collimate point coordinates during prism collimation, select {F2} (CHK) key.</p>	<p>{F2}</p>	<pre>MEAS POINT 1/2 PT#: [PT-01] MSR CHK HR ↓ N [10.000] E [20.000] Z [0.000] ENTER</pre>

● **Checking prism height during prism collimation**

Operating procedure	Operation	Display
<p>1 To check the prism height during prism collimation, select {F3} (HR) key.</p>	<p>{F3}</p>	<pre>MEAS POINT 1/2 PT#: [PT-01] MSR CHK HR ↓ ENTER TARGET HT HT OF ROD =1.500_ m CLR</pre>

● **Checking occupied point coordinates during occupied point/backsight setting**

Operating procedure	Operation	Display
<p>1 To check the occupied point coordinates during occupied point/backsight setting, select {F2} (NEZ) key.</p>	<p>{F2}</p>	<pre>POINT X SET! ORIENTATION SET! OK NEZ ↓ N [0.000] E [0.000] Z [0.000] ENTER</pre>

To set backsight

After completing the occupied point setting, the display for backsight setting will be displayed.

● **Setting from existing coordinate data**

Operating procedure	Operation	Display
<ul style="list-style-type: none"> When the occupied point setting is completed, this menu screen will be displayed. 		<pre>1.SELECT BS PT 2.CREATE BS PT 3.BS DIRECTION [1] [2] [3]</pre>
<p>1 Select {F1} (SELECT BS PT).</p>	{F1}	<pre>ENTER BS POINT PT#: [] ↑ ↓ ALP CLR</pre>
<p>2 Select an existing coordinate point with {F1} or {F2} (Arrow) key, or enter a coordinate point directly.</p>	Enter/ Select PT#	<pre>ENTER BS POINT PT#: [BS-PT_] ↑ ↓ ALP CLR</pre>
<p>3 Set with {ENT} key.</p>	{ENT}	<pre>ENTER BS HEIGHT BS HT =0.000_ m CLR</pre>
<p>4 Enter a reflector height.</p>	Enter reflector height	<pre>ENTER BS HEIGHT BS HT =1.500_ m CLR</pre>
<p>5 Set with {ENT} key.</p>	{ENT}	<pre>SIGHT BS TARGET 1.MEAS ANG+DIST 2.MEAS ANG ONLY</pre>
<p>6 Measure collimate point to set up backsight. To measure distance, and to seek deviation with missing line distance calculated from coordinate data, select {F1} (MEAS ANG + DIST); and to set up only the angle, select {F2} (MEAS ANG ONLY).</p>		<pre>BS DIST CHECK dDIST = m MSR OK</pre>
<ul style="list-style-type: none"> For example, select {F1} 		
<p>7 Select {F1} (MSR). The distance to collimate point will be measured and the difference to the distance sought from coordinate data will be displayed.</p>	{F1}	<pre>BS DIST CHECK dDIST = 0.000 m MSR OK</pre>
<p>8 Pressing {F4} (OK) will complete the backsight setting.</p>	{F4}	<pre>1.INST SETUP 2.LAYOUT 3.TOPO [1] [2] [3]</pre>

● **Setting by entering the coordinate data of a collimate point directly**

Operating procedure	Operation	Display
<ul style="list-style-type: none"> After the occupied point setting is completed, this menu will be displayed. 		<pre>1.SELECT BS PT 2.CREATE BS PT 3.BS DIRECTION [1] [2] [3]</pre>
<p>1 Select {F2} (CREATE BS PT).</p>	{F2}	<pre>1.INPUT PT 2.MEAS PT [1] [2]</pre>
<p>2 Select {F1} (INPUT PT).</p>	{F1}	<pre>ENTER NEW POINT: PT#: [_] DESC: [_] ALP CLR</pre>
<p>3 Enter the coordinate point of a collimate point and its description.</p>	Enter PT #, Enter DESC	<pre>ENTER NEW POINT: PT#: [BS] DESC: [POINT_] ALP CLR</pre>
<p>4 Set with {ENT} key.</p>	{ENT}	<pre>N [] E [] Z [] ALP CLR</pre>
<p>5 Enter collimate point coordinates (N, E, Z).</p>	Enter collimate point coordinate	<pre>N [10.000] E [10.000] Z [0.000] ALP CLR</pre>
<p>6 Set with {ENT} key.</p>	{ENT}	<pre>ENTER BS HEIGHT BS HT =0.000_ m CLR</pre>
<p>7 Enter a reflector height.</p>	Enter reflector height	<pre>ENTER BS HEIGHT BS HT =1.500_ m CLR</pre>
<p>8 Set with {ENT} key.</p>	{ENT}	<pre>SIGHT BS TARGET 1.MEAS ANG+DIST 2.MEAS ANG ONLY</pre>
<p>9 From here to the backsight setting, follow the same procedure to set backsight from existing coordinate data.</p>		<p style="text-align: center;">↓</p>

● Using an existing horizontal angle and saving the coordinate data of the collimate point

Operating procedure	Operation	Display
<ul style="list-style-type: none"> After the occupied point setting is completed, this menu will be displayed. 		<pre>1.SELECT BS PT 2.CREATE BS PT 3.BS DIRECTION [1] [2] [3]</pre>
1 Select {F2} (CREATE BS PT).	{F2}	<pre>1.INPUT PT 2.MEAS PT [1] [2]</pre>
2 Select {F2} (MEAS PT).	{F2}	<pre>ENTER NEW POINT: PT#: [_] DESC: [_] ALP CLR</pre>
3 Enter the coordinate point of a collimate point and its description to record.	Enter PT #, Enter DESC	<pre>ENTER NEW POINT: PT#: [BS] DESC: [POINT_] ALP CLR</pre>
4 Set with {ENT} key.	{ENT}	<pre>ENTER BS HEIGHT BS HT =0.000_ m CLR</pre>
5 Enter a reflector height.	Enter reflector height	<pre>ENTER BS HEIGHT BS HT =1.500_ m CLR</pre>
6 Set with {ENT} key.	{ENT}	<pre>SIGHT BS TARGET HD: m MSR</pre>
7 Collimate the reflector and press {F1} (MSR) key to begin measurement.	{F1}	<pre>SIGHT BS TARGET HD* <<< m >Measuring...</pre>
8 After measuring the reflector, record the coordinate data to complete the setting.		<pre>1.INST SETUP 2.LAYOUT 3.TOPO [1] [2] [3]</pre>

● Setting by entering backsight directly

Operating procedure	Operation	Display
<ul style="list-style-type: none"> After the occupied point setting is completed, this menu will be displayed. 		<pre>1.SELECT BS PT 2.CREATE BS PT 3.BS DIRECTION [1] [2] [3]</pre>

<p>1 Select {F3} (BS DIRECTION).</p>	<p>{F3}</p>	<pre>ENTER BS ANGLE BS AN[_] DDD.MMSS OSET CLR</pre>
<p>2 Enter a backsight directly. Pressing {F1} (OSET) will enter 0.</p>	<p>Enter backsight</p>	<pre>ENTER BS ANGLE BS AN[0.0000_] DDD.MMSS OSET CLR</pre>
<p>3 Set with {ENT} key.</p>	<p>{ENT}</p>	<pre>SIGHT BS TARGET >OK ? [YES] [NO]</pre>
<p>4 Collimate the reflector and press {F3} (YES). Set backsight to end.</p>	<p>{F3}</p>	<pre>1 . INST SETUP 2 . LAYOUT 3 . TOPO [1] [2] [3]</pre>

19.4.2 To Layout

Operating procedure	Operation	Display
		<pre> 1 . INST SETUP 2 . LAYOUT 3 . TOPO [1] [2] [3] </pre>
1 Select {F2} (LAYOUT).	{F2}	<pre> ENTER TARGET HT HT OF ROD =0.000_ m CLR </pre>
2 Enter a reflector height.	Enter reflector height	<pre> ENTER TARGET HT HT OF ROD =1.500_ m CLR </pre>
3 Set with {ENT} key.	{ENT}	<pre> ENTER LAYOUT POINT# PT#: [_] DESC: [_] ↑ ↓ ALP CLR </pre>
4 Select a coordinate point to layout with {F1} or {F2} (Arrow) key, or enter a coordinate point directly.	Enter/ Select PT#	<pre> ENTER LAYOUT POINT# PT#: [P01_] DESC: [_] ↑ ↓ ALP CLR </pre>
5 Set with {ENT} key. The data displayed will be Line 1: Horizontal angle to layout point (Difference) Line 2: Cross directional distance to layout point (Difference) Line 3: Vertical distance to layout point (Difference)	{ENT}	<pre> dHA: 45°00'00" IN : m CUT: m MSR R/L REC NEXT </pre>
6 Pressing {F1} (MSR) will perform distance measurement and it will also display the distance difference.	{F1}	<pre> dHA: 45°00'00" IN : 2.500 m CUT: 0.010 m MSR R/L REC NEXT </pre>
• Data is updated each time (MSR) is performed.		
7 Pressing {F2} (R/L) key will display distance difference in the horizontal direction, instead of the difference in the horizontal angle. Line 1: Horizontal distance to layout point (Difference) Line 2: Cross directional distance to layout point (Difference) Line 3: Vertical distance to layout point (Difference)	{F2}	<pre> R : 1.250 m IN : 2.500 m CUT: 0.010 m MSR NEZ REC NEXT </pre>

<p>8 Pressing {F2} (NEZ) key will display coordinate data. Line 1: N coordinate (E coordinate) Line 2: E coordinate (N coordinate) Line 3: Z coordinate</p> <ul style="list-style-type: none"> Pressing {F2} (dHA) will return to the angle difference display. 	{F2}	<table border="1"> <tr><td>N :</td><td>1.250 m</td></tr> <tr><td>E :</td><td>2.500 m</td></tr> <tr><td>Z :</td><td>0.010 m</td></tr> <tr><td>MSR</td><td>dHA REC NEXT</td></tr> </table>	N :	1.250 m	E :	2.500 m	Z :	0.010 m	MSR	dHA REC NEXT
N :	1.250 m									
E :	2.500 m									
Z :	0.010 m									
MSR	dHA REC NEXT									
<p>9 Press {F3} (REC) key to record the data and move to layout for the next point, and press {F4} (NEXT) key to move to layout for the next point without saving the data. The number in the coordinate point will automatically be incremented.</p>	{F3} or {F4}	<table border="1"> <tr><td colspan="2">ENTER LAYOUT POINT#</td></tr> <tr><td>PT#:</td><td>[P02_]</td></tr> <tr><td>DESC:</td><td>[]</td></tr> <tr><td>↑</td><td>↓ ALP CLR</td></tr> </table>	ENTER LAYOUT POINT#		PT#:	[P02_]	DESC:	[]	↑	↓ ALP CLR
ENTER LAYOUT POINT#										
PT#:	[P02_]									
DESC:	[]									
↑	↓ ALP CLR									

19.4.3 To Conduct Ordinary Measurement and to Record Coordinates

Operating procedure	Operation	Display								
1 Select {F3} (TOPO).	{F3}	<table border="1"> <tr><td>1. INST SETUP</td></tr> <tr><td>2. LAYOUT</td></tr> <tr><td>3. TOPO</td></tr> <tr><td>[1] [2] [3]</td></tr> </table>	1. INST SETUP	2. LAYOUT	3. TOPO	[1] [2] [3]				
1. INST SETUP										
2. LAYOUT										
3. TOPO										
[1] [2] [3]										
2 Enter the coordinate point and its description to record. * 1)	Enter PT#, Enter DESC	<table border="1"> <tr><td>PT#:</td><td>[]</td></tr> <tr><td>DESC:</td><td>[]</td></tr> <tr><td>HT ROD:</td><td>1.500 m</td></tr> <tr><td>HR</td><td>ALP CLR</td></tr> </table>	PT#:	[]	DESC:	[]	HT ROD:	1.500 m	HR	ALP CLR
PT#:	[]									
DESC:	[]									
HT ROD:	1.500 m									
HR	ALP CLR									
3 Set with {ENT} key. * 2)	{ENT}	<table border="1"> <tr><td>PT#:</td><td>[P01]</td></tr> <tr><td>DESC:</td><td>[POINT]</td></tr> <tr><td>HT ROD:</td><td>1.500 m</td></tr> <tr><td>FAST EDIT</td><td>HR MSR</td></tr> </table>	PT#:	[P01]	DESC:	[POINT]	HT ROD:	1.500 m	FAST EDIT	HR MSR
PT#:	[P01]									
DESC:	[POINT]									
HT ROD:	1.500 m									
FAST EDIT	HR MSR									
4 To record the coordinate data without checking measured data, select {F1} (FAST) key.	{F1}	<table border="1"> <tr><td>PT#:</td><td>[P01]</td></tr> <tr><td>DESC:</td><td>[POINT]</td></tr> <tr><td>HT ROD:</td><td>1.500 m</td></tr> <tr><td colspan="2">>Measuring...</td></tr> </table>	PT#:	[P01]	DESC:	[POINT]	HT ROD:	1.500 m	>Measuring...	
PT#:	[P01]									
DESC:	[POINT]									
HT ROD:	1.500 m									
>Measuring...										
5 The measured coordinate data will be recorded, and the number in the coordinate point will automatically be incremented.	Save data	<table border="1"> <tr><td>PT#:</td><td>[P02]</td></tr> <tr><td>DESC:</td><td>[POINT]</td></tr> <tr><td>HT ROD:</td><td>1.500 m</td></tr> <tr><td>FAST EDIT</td><td>HR MSR</td></tr> </table>	PT#:	[P02]	DESC:	[POINT]	HT ROD:	1.500 m	FAST EDIT	HR MSR
PT#:	[P02]									
DESC:	[POINT]									
HT ROD:	1.500 m									
FAST EDIT	HR MSR									
6 To record the coordinate data while checking measured data, select {F4} (MSR) key.	{F4}	<table border="1"> <tr><td>VA:</td><td>90°00'00"</td></tr> <tr><td>HA:</td><td>120°00'00"</td></tr> <tr><td>HD:</td><td>m</td></tr> <tr><td>MSR</td><td>SD NEZ REC</td></tr> </table>	VA:	90°00'00"	HA:	120°00'00"	HD:	m	MSR	SD NEZ REC
VA:	90°00'00"									
HA:	120°00'00"									
HD:	m									
MSR	SD NEZ REC									
7 Measure with {F1} (MSR) key.	{F1}	<table border="1"> <tr><td>VA:</td><td>60°00'00"</td></tr> <tr><td>HA:</td><td>120°00'00"</td></tr> <tr><td>HD:</td><td>10.000 m</td></tr> <tr><td>MSR</td><td>SD NEZ REC</td></tr> </table>	VA:	60°00'00"	HA:	120°00'00"	HD:	10.000 m	MSR	SD NEZ REC
VA:	60°00'00"									
HA:	120°00'00"									
HD:	10.000 m									
MSR	SD NEZ REC									

8 Pressing **{F2}** (SD) key will switch the distance display to the SD display.

{F2}

VA:	60°00'00"		
HA:	120°00'00"		
HD:	11.547 m		
MSR	HD	NEZ	REC

9 Pressing **{F3}** (NEZ) key will switch to the coordinate display.

{F3}

N :	-5.000 m		
E :	8.660 m		
Z :	5.774 m		
MSR	HD	A/D	REC

10 Pressing **{F3}** (A/D) key will switch to the previously measured angle/measured distance display.

{F3}

VA:	60°00'00"		
HA:	120°00'00"		
HD:	11.547 m		
MSR	HD	NEZ	REC

11 Pressing **{F4}** (REC) key will record the data.

{F4}

PT#:	[P02]
DESC:	[POINT]
HT ROD:	1.500 m	
FAST EDIT	HR	MSR

- Data to be recorded are recalculated from the currently displayed angle and horizontal distance (angle offset function).

To record the coordinate data of the collimate point, record (REC) them without moving the angle after measurement (MSR).

*1) To change the reflector height, select **{F2}** (HR) key to switch to the screen for reflector height input.

PT#:	[P01]
DESC:	[POINT]
HT ROD:	1.500 m	
HR	ALP	CLR

{F2}

ENTER TARGET HT
HT OF ROD
=1.500_ m
CLR

*2) To edit a coordinate point and its description, select **{F2}** (EDIT) key to return to the editing mode.

PT#:	[P01]
DESC:	[POINT]
HT ROD:	1.500 m	
FAST EDIT	HR	MSR

{F2}

PT#:	[P01_]
DESC:	[POINT]
HT ROD:	1.500 m	
HR	ALP	CLR

19.5 DATA MANAGER

The following operations can be performed with DATA MANAGER.

- | | |
|---------------------------------|--------------------|
| 1) Adding coordinate data |ADD POINT |
| 2) Deleting coordinate data |DELETE POINT |
| 3) Viewing coordinate data |VIEW POINT |
| 4) Editing coordinate data |EDIT POINT |
| 5) Transferring coordinate data |DATA TRANSFER |

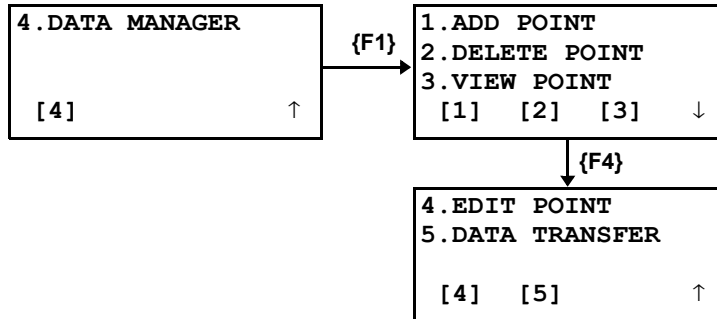

19.5.1 To Add Coordinate Data

Operating procedure	Operation	Display
Select {F1} (ADD POINT). Coordinates can be added through the following procedure: 1. COORDINATES 2. REFLINE 3. TAPE	{F1}	1 . ADD POINT 2 . DELETE POINT 3 . VIEW POINT [1] [2] [3] ↓
		1 . COORDINATES 2 . REFLINE 3 . TAPE [1] [2] [3]

● Entering coordinates directly (COORDINATES)

Operating procedure	Operation	Display
1 Select {F1} (COORDINATES). 2 Enter a coordinate point and its description. 3 Set with {ENT} key.	{F1}	1 . COORDINATES 2 . REFLINE 3 . TAPE [1] [2] [3]
		ENTER NEW POINT : PT# : [_] DESC : [] ALP CLR
	Enter PT#, Enter DESC	{ENT}
		N [_] E [] Z [] CLR

<p>4 Enter N/E/Z coordinates.</p>	<p>Enter NEZ Coordinate Data</p>	<pre>N [0.000] E [0.000] Z [0.000_] CLR</pre>
<p>5 Set with {ENT} key. The coordinate point and the job name will be displayed and the procedure will be completed.</p>	<p>{ENT}</p>	<pre>PT#: [P01] STORED! JOB [JOB1]</pre>
		<p style="text-align: center;">↓</p> <pre>1. COORDINATES 2. REFLINE 3. TAPE [1] [2] [3]</pre>

● REFLINE

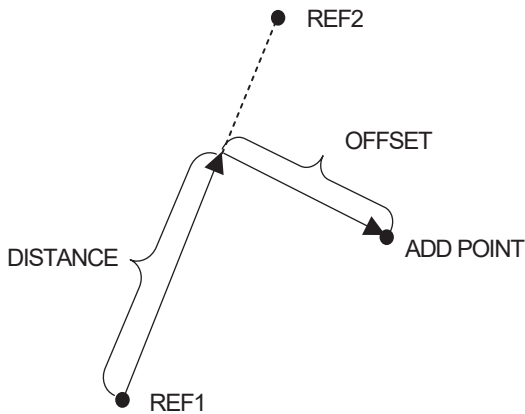

Operating procedure	Operation	Display
<p>1 Select {F2} (REFLINE).</p>	{F2}	<pre>1. COORDINATES 2. REFLINE 3. TAPE [1] [2] [3]</pre>
<p>2 To acquire coordinate data for reference "REF1," select an existing coordinate point with {F1} or {F2} (Arrow) key, or enter a coordinate point directly.</p>	<p>Enter/ Select PT#</p>	<pre>ENTER REF1 PT#: [_] DESC: ↑ ↓ ALP CLR</pre>
<p>3 Set with {ENT} key.</p>	{ENT}	<pre>ENTER REF1 PT#: [P01_] DESC: ↑ ↓ ALP CLR</pre>
		<pre>ENTER REF2 PT#: [_] DESC: ↑ ↓ ALP CLR</pre>

4 Acquire coordinate data for Reference "REF2" in the same manner.

Enter/
Select PT#

```

ENTER REF2
PT#: [P02_ ]
DESC:
  ↑   ↓   ALP CLR
    
```

5 Enter the distance (DISTANCE) from reference "REF1" to the direction of "REF2".

Enter
DISTANCE

```

ENTER DISTANCE
= _ m
          CLR
    
```

```

ENTER DISTANCE
= 10.000_ m
          CLR
    
```

6 Set with {ENT} key.

{ENT}

```

ENTER OFFSET
L = _ m
LEFT RIGHT CLR
    
```

7 Enter the horizontal direction distance (OFFSET). To select directions, press {F1} (LEFT) to move to the left and {F2} (RIGHT) to the right.

Enter
OFFSET,
{F1} or
{F2}

```

ENTER OFFSET
R = 5.000_ m
LEFT RIGHT CLR
    
```

8 Set with {ENT} key. The conditions for calculating coordinate data will be displayed.

{ENT}

```

REF1 [P01 ]
REF2 [P02 ]
OK EDIT ↓
    
```

9 {F4} (↑/↓) will allow the switching of the "REF1/REF2" display and "DISTANCE/OFFSET" display.

{F4}

```

DIS:      10.000 m
R :       5.000 m
OK EDIT ↑
    
```

10 Press {F1} (OK) to calculate coordinate data. After the coordinate data is calculated, the procedure will move onto coordinate point/description entries.

{F1}

```

ENTER NEW POINT:
PT#: [ _ ]
DESC: [ _ ]
          ALP CLR
    
```

The procedures below will be the same as the ones for entering coordinates directly (COORDINATE).

Enter PT#,
Enter
description

```

ENTER NEW POINT:
PT#: [P03 ]
DESC: [POINT_ ]
          ALP CLR
    
```

{ENT}

```

N [ 10.000 ]
E [ 5.000 ]
Z [ 0.000 ]
          ENTER
    
```

- The calculated value will be displayed for the coordinate data. Set with {ENT} key.

{ENT}

PT#:	[P03]
	STORED!	
JOB	[JOB 1]

↓

1. COORDINATES
2. REFLINE
3. TAPE
[1] [2] [3]

● TAPE

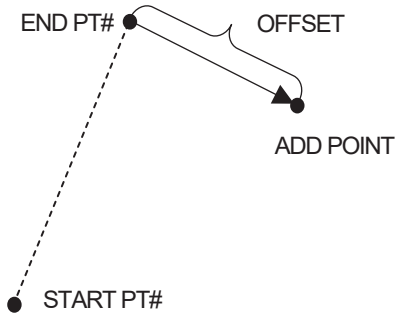

Operating procedure	Operation	Display							
1 Select {F3} (TAPE).	{F3}	<table border="1"> <tr> <td>1. COORDINATES</td> </tr> <tr> <td>2. REFLINE</td> </tr> <tr> <td>3. TAPE</td> </tr> <tr> <td>[1] [2] [3]</td> </tr> </table>	1. COORDINATES	2. REFLINE	3. TAPE	[1] [2] [3]			
1. COORDINATES									
2. REFLINE									
3. TAPE									
[1] [2] [3]									
2 In order to acquire coordinate data for reference "START" point, select an existing coordinate point with {F1} or {F2} (Arrow) key, or enter a coordinate point directly.	Enter/ Select PT#	<table border="1"> <tr> <td>ENTER START PT#</td> </tr> <tr> <td>PT#:</td> <td>[_]</td> </tr> <tr> <td>DESC:</td> <td></td> </tr> <tr> <td>↑</td> <td>↓ ALP CLR</td> </tr> </table>	ENTER START PT#	PT#:	[_]	DESC:		↑	↓ ALP CLR
ENTER START PT#									
PT#:	[_]								
DESC:									
↑	↓ ALP CLR								
3 Set with {ENT} key.	{ENT}	<table border="1"> <tr> <td>ENTER START PT#</td> </tr> <tr> <td>PT#:</td> <td>[P01_]</td> </tr> <tr> <td>DESC:</td> <td></td> </tr> <tr> <td>↑</td> <td>↓ ALP CLR</td> </tr> </table>	ENTER START PT#	PT#:	[P01_]	DESC:		↑	↓ ALP CLR
ENTER START PT#									
PT#:	[P01_]								
DESC:									
↑	↓ ALP CLR								
4 In order to acquire coordinate data for reference "END" point, select an existing coordinate point with {F1} or {F2} (Arrow) key, or enter a coordinate point directly.	Enter/ Select PT#	<table border="1"> <tr> <td>ENTER END PT#</td> </tr> <tr> <td>PT#:</td> <td>[_]</td> </tr> <tr> <td>DESC:</td> <td></td> </tr> <tr> <td>↑</td> <td>↓ ALP CLR</td> </tr> </table>	ENTER END PT#	PT#:	[_]	DESC:		↑	↓ ALP CLR
ENTER END PT#									
PT#:	[_]								
DESC:									
↑	↓ ALP CLR								
5 Set with {ENT} key.	{ENT}	<table border="1"> <tr> <td>ENTER END PT#</td> </tr> <tr> <td>PT#:</td> <td>[P02_]</td> </tr> <tr> <td>DESC:</td> <td></td> </tr> <tr> <td>↑</td> <td>↓ ALP CLR</td> </tr> </table>	ENTER END PT#	PT#:	[P02_]	DESC:		↑	↓ ALP CLR
ENTER END PT#									
PT#:	[P02_]								
DESC:									
↑	↓ ALP CLR								
	{ENT}	<table border="1"> <tr> <td>ENTER FROM END PT#</td> </tr> <tr> <td>L = _ m</td> </tr> <tr> <td>LEFT RIGHT CLR</td> </tr> </table>	ENTER FROM END PT#	L = _ m	LEFT RIGHT CLR				
ENTER FROM END PT#									
L = _ m									
LEFT RIGHT CLR									

<p>6 Enter the horizontal distance (OFFSET) from "END" point. To select directions, press {F1} (LEFT) to move to the left and {F2} (RIGHT) to the right.</p>	<p>Enter OFFSET, {F1} or {F2}</p>	<pre> ENTER FROM END PT# R = 5.000 m LEFT RIGHT CLR </pre>
<p>7 Set with {ENT} key. The conditions for calculating coordinate data will be displayed.</p>	<p>{ENT}</p>	<pre> START [P01] END [P02] R : 5.000 m OK EDIT ↓ </pre>
<p>8 Press {F1} (OK) to calculate coordinate data. After the coordinate data is calculated, the procedure will move onto coordinate point/description entries.</p>	<p>{F1}</p>	<pre> ENTER NEW POINT: PT#: [_] DESC: [_] ALP CLR </pre>
<ul style="list-style-type: none"> The procedures below will be the same as the ones for entering coordinates directly (COORDINATE). 	<p>Enter PT#, Enter DESC</p>	<pre> ENTER NEW POINT: PT#: [P03] DESC: [POINT_] ALP CLR </pre>
<ul style="list-style-type: none"> The calculated value will be displayed for the coordinate data. Set with {ENT} key. 	<p>{ENT}</p>	<pre> N [10.000] E [5.000] Z [0.000] ENTER </pre>
	<p>{ENT}</p>	<pre> PT#: [P03] STORED! JOB [JOB1] </pre>
		<pre> 1. COORDINATES 2. REFLINE 3. TAPE [1] [2] [3] </pre>

19.5.2 To Delete Coordinate Data

Operating procedure	Operation	Display
<p>1 Select {F2} (DELETE POINT).</p>	<p>{F2}</p>	<pre> 1. ADD POINT 2. DELETE POINT 3. VIEW POINT [1] [2] [3] ↓ </pre>
<p>2 Select the type of data to delete. {F1} (DESIGN PT) Coordinate data entered directly and recorded for addition of coordinates {F2} (MEASUREMENT PT) Coordinate data observed and recorded through layout, TOPO, etc.</p>	<p>{F1} or {F2}</p>	<pre> 1. DESIGN PT 2. MEASUREMENT PT [1] [2] ENTER PT TO DEL PT#: [_] DESC: [_] ↑ ↓ ALP CLR </pre>

<p>3 Select a coordinate point to delete with {F1} or {F2} (Arrow) key, or enter a coordinate point directly.</p>	<p>Enter/ Select PT#</p>	<pre> ENTER PT TO DEL PT#: [P01_] DESC: [] ↑ ↓ ALP CLR </pre>
<p>4 Set with {ENT} key.</p>	<p>{ENT}</p>	<pre> ENTER PT TO DEL PT#: [P01] DESC: [] >OK ? [YES] [NO] </pre>
<p>5 When deleting data, there will be a verification procedure. Selecting {F3} (YES) here will delete the coordinate data selected.</p>	<p>{F3}</p>	<pre> POINT DELETED! ↓ 1.DESIGN PT 2.MEASUREMENT PT [1] [2] </pre>

19.5.3 To View Coordinate Data

Operating procedure	Operation	Display
<p>1 Select {F3} (VIEW POINT).</p>	<p>{F3}</p>	<pre> 1.ADD POINT 2.DELETE POINT 3.VIEW POINT [1] [2] [3] ↓ 1.DESIGN PT 2.MEASUREMENT PT [1] [2] </pre>
<p>2 Select type of data to view. {F1} (DESIGN PT) Coordinate data entered directly and recorded for addition of coordinates {F2} (MEASUREMENT PT) Coordinate data observed and recorded through layout, TOPO, etc.</p>	<p>{F1} or {F2}</p>	<pre> DESIGN PT PT#: [P01] DESC: [POINT] ↑ ↓ NEZ </pre>
<p>3 Select a coordinate point to view with {F1} or {F2} (Arrow) key.</p>	<p>Enter/ Select PT#</p>	<pre> DESIGN PT PT#: [P99] DESC: [POINT] ↑ ↓ NEZ </pre>
<p>4 To check the coordinate data, press {F4} (NEZ).</p>	<p>{F4}</p>	<pre> N [0.000] E [0.000] Z [0.000] ↑ ↓ PT# </pre>
<p>5 Pressing {F4} (PT#) will return to the coordinate point display.</p>	<p>{F4}</p>	<pre> DESIGN PT PT#: [P99] DESC: [POINT] ↑ ↓ NEZ </pre>

19.5.4 To Edit Coordinate Data

Operating procedure	Operation	Display
<ul style="list-style-type: none"> Only entered coordinate data (design data) can be edited. 		<pre> 4 .EDIT POINT 5 .DATA TRANSFER [4] [5] ↑ </pre>
<ol style="list-style-type: none"> Select {F1} (EDIT POINT). 	{F1}	<pre> DESIGN PT PT#: [P01] DESC: [POINT] ↑ ↓ EDIT NEZ </pre>
<ol style="list-style-type: none"> Select a coordinate point to edit with {F1} or {F2} (Arrow) key. 	{F1} or {F2}	<pre> DESIGN PT PT#: [P99] DESC: [POINT] ↑ ↓ EDIT NEZ </pre>
<ol style="list-style-type: none"> Switch to the editing mode by pressing {F3} (Edit) key. 	{F3}	<pre> DESIGN PT PT#: [P99_] DESC: [POINT] ALP CLR </pre>
<ol style="list-style-type: none"> After editing the coordinate point and its description, set with {ENT} key. 	Edit data {ENT}	<pre> DESIGN PT PT#: [PT-99] DESC: [POINT] ↑ ↓ EDIT NEZ </pre>
<ul style="list-style-type: none"> Coordinate data can be edited with the editing mode in the same manner. 		<pre> N [0.000] E [0.000] Z [0.000] ↑ ↓ EDIT PT# </pre> <p style="text-align: center;">↓</p> <pre> N [0.000_] E [0.000] Z [0.000] CLR </pre>

19.5.5 To Transfer Coordinate Data

Operating procedure	Operation	Display
<p>1 Select {F2} (DATA TRANSFER). Data transfer corresponds to the following two types of transmission formats: F1: GTS FORMAT F2: SSS FORMAT</p>	{F2}	<div style="border: 1px solid black; padding: 5px;"> <p>4 . EDIT POINT 5 . DATA TRANSFER</p> <p>[4] [5] ↑</p> </div> <div style="border: 1px solid black; padding: 5px;"> <p>DATA TRANSFER F1 : GTS FORMAT F2 : SSS FORMAT</p> </div>

● Setting Transmission Protocol

Operating procedure	Operation	Display
<ul style="list-style-type: none"> Always check transmission protocol before performing data transfer. 		<div style="border: 1px solid black; padding: 5px;"> <p>DATA TRANSFER F1 : GTS FORMAT F2 : SSS FORMAT</p> </div>
<p>1 Select the transmission format to use.</p>	{F1} or {F2}	<div style="border: 1px solid black; padding: 5px;"> <p>DATA TRANSFER F1 : SEND DATA F2 : LOAD DATA F3 : COMM. PARAMETERS</p> </div>
<p>2 Select {F3} (COMM. PARAMETERS)</p>	{F3}	<div style="border: 1px solid black; padding: 5px;"> <p>COMM. PARAMETERS F1 : BAUD RATE F2 : CHAR. / PARITY F3 : STOP BITS</p> </div>

Set items for transmission protocol are as follows according to the format.

● GTS FORMAT

Item	Selecting Item	Contents
Protocol	[ACK/NAK], [ONE WAY]	Setting Protocol [ACK/NAK] or [ONE WAY] communication
Baud rate	1200, 2400, 4800, 9600, 19200, 38400	Setting transfer speed 1200/2400/4800/9600/19200/38400 baud
Char. / Parity	[7/EVEN], [7/ODD], [8/NON]	Setting data length and parity. [7 bit, even], [7 bit, odd], [8 bit, none]
Stop Bits	1, 2	Setting Stop 1 bit or 2bits

● SSS FORMAT

Item	Selecting Item	Contents
Baud rate	1200, 2400, 4800, 9600, 19200, 38400	Setting transfer speed 1200/2400/4800/9600/19200/38400 baud
Char. / Parity	[7/EVEN], [7/ODD], [8/NON]	Setting data length and parity. [7 bit, even], [7 bit, odd], [8 bit, none]
Stop Bits	1, 2	Setting Stop 1 bit or 2bits

● Receiving coordinate data

Operating procedure	Operation	Display
<p>1 Select the transmission format used for receiving data.</p> <p>F1: GTS FORMAT F2: SSS FORMAT</p> <p>2 Select {F2} (LOAD DATA).</p> <p>3 Press {F3} (YES) to begin the coordinate data receiving process.</p>	<p>{F1} or {F2}</p> <p>{F2}</p> <p>{F3}</p>	<p>DATA TRANSFER F1:GTS FORMAT F2:SSS FORMAT</p>
		<p>DATA TRANSFER F1:SEND DATA F2:LOAD DATA F3:COMM. PARAMETERS</p>
		<p>LOAD COORD. DATA</p> <p>>OK ? --- --- [YES] [NO]</p>
		<p>LOAD COORD. DATA * < Loading Data ! > STOP</p>

● Sending coordinate data

Operating procedure	Operation	Display
<p>1 Select the transmission format used for receiving data.</p> <p>F1: GTS FORMAT F2: SSS FORMAT</p> <p>2 Select {F1} (SEND DATA).</p> <p>3 Press {F3} (YES) to begin the coordinate data sending process.</p>	<p>{F1} or {F2}</p> <p>{F1}</p> <p>{F3}</p>	<p>DATA TRANSFER F1:GTS FORMAT F2:SSS FORMAT</p>
		<p>DATA TRANSFER F1:SEND DATA F2:LOAD DATA F3:COMM. PARAMETERS</p>
		<p>SEND COORD. DATA</p> <p>>OK ? --- --- [YES] [NO]</p>
		<p>SEND COORD. DATA * < Sending Data ! > STOP</p>

20 SPECIAL ACCESSORIES

The following are optional accessories which are sold separately from the GM.

☞ Target and power supply optional accessories: see Section 21 "BATTERY SYSTEM". and 22 "PRISM SYSTEM".

- **Plumb bob**

The plumb bob can be used to set up and center the instrument on days when there is little wind. To use the plumb bob, unwind its cord, pass it through the cord grip piece as shown in the figure to adjust its length, then suspend it from the hook attached to the centering screw.

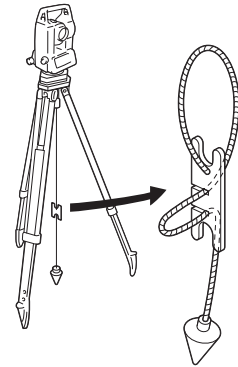

- **Tubular compass (CP7)**

Slide the tubular compass into the tubular compass slot, loosen the clamp screw, then rotate the top part of the instrument until the compass needle bisects the index lines. The telescope's Face 1 sighting direction in this position will indicate magnetic north. After use, tighten the clamp and remove the compass from the slot.

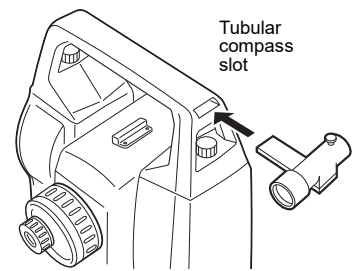

- The tubular compass is susceptible to the influence of nearby magnets or metal. Such influence could cause it to fail to accurately indicate magnetic north. Do not use magnetic north as indicated by this compass for base line surveying.

- **Telescope eyepiece lens (EL7)**

Magnification: 40X
Field of view : 1° 20'

- **Diagonal eyepiece (DE27)**

The diagonal eyepiece is convenient for observations near the nadir and in narrow spaces.
Magnification: 30X

After removing the handle from the GM, loosen the attachment screw to remove the telescope eyepiece. Then screw the diagonal lens into place.

☞ Handle removal method: see Section 1.1 "Nomenclature".

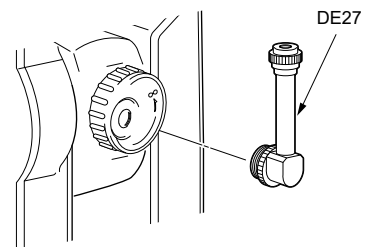

- **Solar filter (OF3A)**

During solar observation, attach it to the objective lens of the GM to protect its interior and the eyes of the operator. The filter part can be flipped up without being removed.

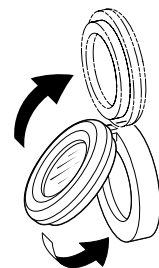

- **Power cable/Interface cable (optional accessory)**

Connect the instrument to a host computer using the following cables.

Cable	Notes
DOC210	Pin number and signal level : RS232C compatible D-Sub connector : 9 pins (female)

21 BATTERY SYSTEM

Operate your instrument with the following combinations of power equipment.



- For details about batteries and chargers, refer to each dedicated manual.
- Never use any combination other than those indicated below. If you do, the instrument could be damaged.
- Those indicated by * are standard accessories. Others are optional accessories for Low Temperature Models.

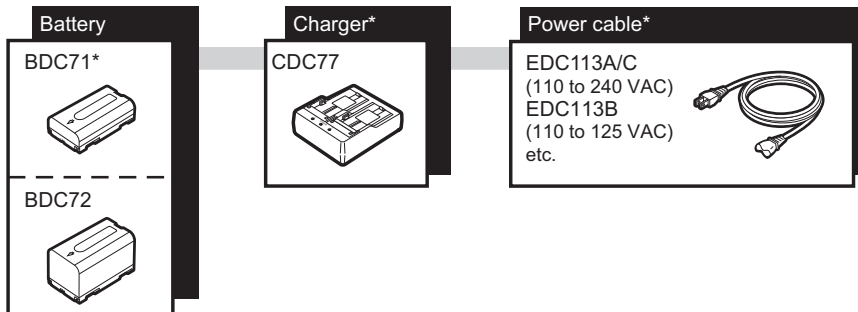

- Dedicated power cables differ according to the country or the area where the instrument is used. Contact your local dealer for the details.

22 PRISM SYSTEM

Select a prism or a target depending on your purpose. The following are all special accessories (sold separately).



- When using a reflecting prism equipped with a target for distance and angle measurements, be sure to direct the reflective prism correctly and sight the center of the prism target accurately.
- Each reflective prism has its own prism constant value. When changing prisms, be sure to change the prism constant correction value.

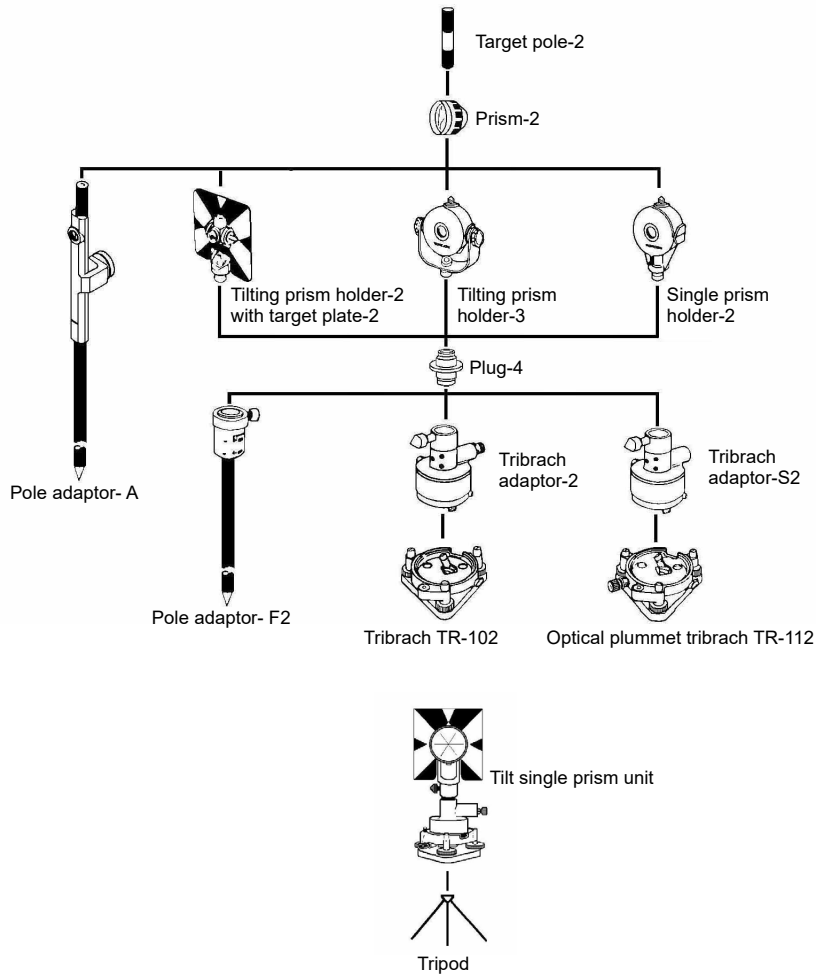

- Plug-4 is necessary for the tribrach adaptor-2, tribrach adaptor-S2 and pole adaptor-F2 to coincide with the height of this series.
Use the above prisms after setting them at the same height as the instruments. To adjust the height of prism set, change the position of fixing screws.
- During a traverse observation, it is recommended to use the same type (tribrach-TR-102/112) of tribrach for the target.

- **Prism-2**
Prism constant correction values differ depending on the prism holders to use. Check the own value which is written on the holder in many cases.
Prism constant correction value : 0 mm/-30 mm
Aperture : 58 mm
- **Prism-5**
Prism constant correction value : 0 mm
Aperture : 32 mm
- **Reflective sheet target (RS series)**
Prism constant correction value : 0 mm
Aperture : Target size
- **2-point target (2RT500-K)**
This target is used for two-distance offset measurement.
Prism constant correction value : 0 mm
Aperture : 50 mm
- **Base Plate (TR-101/102 series)**
The circular level on the base plate for prism should be adjusted in the same way with the circular level on the main body.
 "18.1 Circular Level"

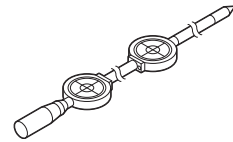

23 ERROR DISPLAYS

The following is a list of the error messages displayed by the instrument and the meaning of each message.



- There is a possibility that an unexpected error occasionally occurs when using an old battery. In such a case, exchange it for a new battery, and please check the operation of the instrument.
- If error still persist after attempting to clear them, contact your local dealer.

Error code	Description	Countermeasures
3 points required	When area calculating, there are less than 3 points coordinate data in selected file.	Confirm the file data and calculate again.
BadCondition	The air is shimmering a lot, etc., measuring conditions are poor. The center of the target cannot be sighted. Unsuitable distance measurement conditions when reflectorless measurement is set. When reflectorless measurement is set, distance cannot be measured because the laser beam is striking at least two surfaces at the same time.	Perform measurement again when measuring condition becomes better. Resight the target. Choose a single surface target for distance measurement.
CALC ERROR	Calculation is impossible from the data input.	Confirm the input data.
DELETE ERROR	When deleting coordinate data, it can not be done successful.	Confirm the data and delete again.
SIGNAL OFF	Measuring conditions are poor, and there is not enough reflective light for measuring distances.	Resight the target. When using reflective prisms, effectiveness will be improved by increasing the number of prisms used.
E020's, E031, E033	EDM error	Repair is required.
E35	Displayed when REM measurement carried out to the range from zenith or nadir $\pm 6^\circ$.	Operate in the range out of $\pm 6^\circ$ from the zenith or nadir.
E72	Displayed when Vertical angle -position is adjusted in wrong position.	Repair is required.
E73	The instrument was not leveled when Vertical angle 0-position is adjusted.	Level the instrument then carry the adjustment work.
E80's	Mainly at the time data transmission between GM and external instrument.	Confirm operation procedure is correct or the connection cables are correct.
E097	EDM device error	Repair is required.
E123, E124	Tilt error	Contact your local dealer.
E198	Angle measurement error	Contact your local dealer.
E201	EDM distance measurement time out error	If the same error message is repeated, repair is required.
E205	Communication with EDM is poor	If the same error message is repeated, repair is required.
FILE EXISTS	The same file name exists.	Use another file name.

FULL FILES	When making a file, 99 files already exist.	If necessary, send or delete files.
LIMIT OVER	Limit of input data exceeded.	Input again.
MEMORY ERROR	Any abnormality occurs with internal memory.	Initialize the internal memory.
MEMORY POOR	Shortage of capacity of the internal memory.	Download data from internal memory to PC.
NO DATA	The data is not found in the search mode	Confirm the data and search again.
NO FILE	There is no file in internal memory.	If necessary, make files.
FILE NOT SELECTED	When using a file, no file is selected.	Confirm the file and select a file.
P1-P2 distance too short	When in point to line measurement, the horizontal distance between first point and second point is within 1 m.	The horizontal distance between first point and second point must be more than 1 m.
CIRCULAR ERROR	Known points and occupied point are on the same circle at the resection mode.	Take the different point.
PT# EXIST	Same new point name is already memorized in the memory.	Confirm the new point name and input again.
PT# DOES NOT EXIST	When you enter incorrect name or PT# does not exist in the internal memory.	Enter the correct name or enter point in the internal memory.
RANGE ERROR	When setting a new point, calculation is impossible from the measured data.	Measure again.
READ ONLY FILE	Read-only file on the USB flash drive cannot be changed and file contents cannot be deleted or edited.	Remove the read -only attribute of the file on your PC etc.
Temp RangeOUT	GM is outside useable temperature range and accurate measurement cannot be performed.	Repeat measurement within the appropriate temperature range. If the GM is used under direct sunlight, use an umbrella to protect it against the heat of the sun.
Tilt Over	Instrument tilts over more than 6 minutes and 30 seconds.	Level the instrument properly.
USB ERROR	An error has occurred in loading or saving data to USB flash drive.	Check if the USB flash drive is formatted to FAT32. Insert the USB flash drive correctly. If the error still occurs, use another USB flash drive.
V ANGLE ERROR H ANGLE ERROR VH ANGLE ERROR	Abnormality in angle measuring system.	If this error code continues to display, repair is required.

24 SPECIFICATIONS

Except where stated, the following specifications apply to all models of GM Series.

Telescope

Length	171 mm
Aperture	45 mm (EDM:48 mm)
Magnification	30X
Image	Erect
Resolving power	2.5"
Field of view	1°30'
Minimum focus	1.3 m
Reticle illumination	5 brightness levels

Angle measurement

Horizontal and Vertical circles type	Rotary absolute encoder
Detecting	
GM-62:	2 sides
GM-65:	1 side
Angle units	Degree/Gon/Mil (selectable)
Minimum display	
GM-62/65:	1" (0.0002 gon/0.005 mil)/5" (0.0010 gon/0.02 mil) (selectable)
Accuracy	
GM-62:	2" (0.0006 gon/0.010 mil)
GM-65:	5" (0.0015 gon/0.025 mil)
(ISO 17123-3 : 2001)	
Measuring time	0.5 sec or less
Collimation compensation	On/Off (selectable)
Measuring mode	
Horizontal angle:	Right/Left (selectable)
Vertical angle:	Zenith/Horizontal/Horizontal $\pm 90^\circ$ /% (selectable)

Tilt angle compensation

Type	Liquid 2-axis tilt sensor
Minimum display	1"
Range of compensation	$\pm 6'$ (± 0.1111 gon)
Automatic compensator	ON (V & H/V)/OFF (selectable)
Compensation constant	Can be changed

Distance Measurement

Measuring method	Coaxial phase shift measuring system
Signal source	Red laser diode (690 nm) Class 3R (IEC60825-1 Ed.3.0: 2014/ FDA CDRH 21CFR Part 1040.10 and 1040.11 (Complies with FDA performance standards for laser products except for deviations pursuant to Laser Notice No.56, dated May 8, 2019.)) (When the prism or reflective sheet is selected in Config mode as target, the output is equivalent to Class 1). (Using the following reflective prism/reflective sheet target during normal atmospheric conditions* ¹ / * ² is good atmospheric conditions.)
Measuring range	
Mini pole prism Prism-5* ³ :	1.3 to 500 m (1,640 ft)
Standard prism Prism-2 X 1* ³ :	1.3 to 4,000 m (13,120 ft)
Reflective sheet RS90N-K* ⁴ :	(1.3 to 4,000 m (13,120 ft))* ²
Reflective sheet RS50N-K* ⁴ :	1.3 to 500 m (1,640 ft)
Reflective sheet RS50N-K* ⁴ :	1.3 to 300 m (980 ft)* ⁵
Reflective sheet RS50N-K* ⁴ :	1.3 to 300 m (980 ft)
Reflective sheet RS50N-K* ⁴ :	1.3 to 180 m (590 ft)* ⁵
Reflective sheet RS10N-K* ⁴ :	1.3 to 100 m (320 ft)
Reflective sheet RS10N-K* ⁴ :	1.3 to 60 m (190 ft)* ⁵

Reflectorless (White) :	0.3 to 500 m (1,640 ft) ^{*6} (0.3 to 500 m (1,640 ft) ^{*2 *7 *8}
Prism (tracking) ^{*3} :	1.3 to 1,000 m (3,280 ft)
Reflective sheet target (tracking) ^{*4} :	1.3 to 350 m (1,140 ft) 1.3 to 210 m (680 ft) ^{*5}
Reflectorless (White) (tracking, road):	0.3 to 300 m (980 ft) ^{*6}
Minimum display	
Fine measurement:	0.0001 m (0.001 ft / 1/8 inch) / 0.001 m (0.005 ft / 1/8 inch) (selectable)
Coarse measurement:	0.001 m (0.005 ft / 1/8 inch) / 0.01 m (0.02 ft / 1 inch) (selectable)
Tracking/Road measurement:	0.01 m (0.02 ft / 1 inch)
Maximum slope distance display (Except for tracking)	
Using prism or reflective sheet target:	9,600.000 m (31,490 ft)
Reflectorless:	1,200.000 m (3,930 ft)
(Tracking)	
Using prism or reflective sheet target:	1,280.000 m (4,200 ft)
Reflectorless:	768.000 m (2,520ft)
Distance unit	m/ft/inch (selectable)
Accuracy (D: measurement distance; Unit: mm) (Under normal atmospheric conditions ^{*1}) (Using prism) ^{*3}	
Fine measurement:	(1.5 + 2 ppm X D) mm ^{*9 *11}
Rapid measurement:	(5 + 2 ppm X D) mm
(Using reflective sheet target) ^{*12}	
Fine measurement:	(2 + 2 ppm X D) mm
Rapid measurement:	(5 + 2 ppm X D) mm
(Reflectorless (White)) ^{*6}	
Fine measurement:	(2 + 2 ppm X D) mm (0.3 to 200 m) ^{*10} (5 + 10 ppm X D) mm (over 200 to 350 m) (10 + 10 ppm X D) mm (over 350 to 500 m)
Rapid measurement:	(6 + 2 ppm X D) mm (0.3 to 200 m) ^{*10} (8 + 10 ppm X D) mm (over 200 to 350 m) (15 + 10 ppm X D) mm (over 350 to 500 m)
Measurement mode	Fine measurement (single/repeat/average)/Rapid measurement (single/repeat)/Tracking/Road (reflectorless) (selectable)
Measuring time ^{*13} :	
(fastest time under good atmospheric conditions ^{*2} , no compensation, EDM ALC at appropriate setting, slope distance)	
Fine measurement:	less than 1.5 sec + every 0.9 sec or less
Rapid measurement:	less than 1.3 sec + every 0.6 sec or less
Tracking measurement:	less than 1.3 sec + every 0.4 sec or less
Atmospheric correction:	
Temperature input range:	-30.0 to 60.0°C (in 0.1°C step)/ -22.0 to 140.0°F (in 0.1°F step)
Pressure input range:	560.0 to 1,066.0hPa (in 0.1hPa step) 420.0 to 800.0mmHg (in 0.1mmHg step) 16.50 to 31.50inchHg (in 0.01inchHg step)
Humidity input range:	0.0 to 100.0% (in 0.1% step)
ppm input range:	-999.9 to 999.9 ppm (in 0.1 ppm step)
Prism constant correction	-99.9 to 99.9 mm (in 0.1 mm step)
Earth curvature and refraction correction	No/Yes K=0.14/Yes K=0.20 (selectable)
Scale factor setting	0.99 to 1.01
Elevation	-9,999 to 9,999 m

*1: Slight haze, visibility about 20 km, sunny periods, weak scintillation.

*2: No haze, visibility about 40 km, overcast, no scintillation.

*3: Face the prism toward the instrument during the measurement with the distance at 10 m or less.

*4: Figures when the laser beam strikes within 30° of the reflective sheet target.

- *5: Measurement at 50 to 60°C (122 to 140°F) (Standard Model)
- *6: Figures when using Kodak Gray Card White side (reflection factor 90%), brightness level is less than 5,000 lx and the laser beam strikes orthogonally the White side.
- *7: Figures when using Kodak Gray Card White side (reflection factor 90%), brightness level is less than 500 lx and the laser beam strikes orthogonally the White side. (800 m or more)
- *6,*7: When performing reflectorless measurement, the possible measurement range and precision will change depending on the target reflection factor, weather conditions and location conditions.
- *8: Figures may differ according to the country or the area.
- *9: Accuracy is (2 + 2 ppm X D) mm for distance range 1.3 to 2 m.
- *10: Accuracy is (5 + 2 ppm X D) mm for distance range 0.3 to 0.66 m or less.
- *11: ISO 17123-4: 2012
- *12: Figures when the laser beam strikes within 30° of the reflective sheet RS10N-K. When using other reflective sheet targets, face them directly toward the instrument and measure in both Faces 1 and 2 (direct and reverse).
- *13: Figures are as follows when EDM eco mode is selected. Fine measurement: less than 2.0 sec + every 0.9 sec or less, Rapid measurement: less than 1.8 sec + every 0.6 sec or less, Tracking measurement: less than 1.8 sec + every 0.4 sec or less

Internal memory

Capacity about 50,000 points

External memory

USB flash memory (up to 64 GB)

Data transfer

Data input/output

Asynchronous serial, RS232C compatible ^{*14}

USB

USB Revision 2.0 (High Speed), Host (Type A), Only a USB flash drive is compatible.

*14: Only for *Bluetooth* function built-in models.

Bluetooth wireless technology ^{*15}

Transmission method

FHSS

Modulation

GFSK (Gaussian-filtered frequency shift keying)

Frequency band

2.402 to 2.480GHz

Bluetooth profile

SPP, DUN

Power class

Class 1.5

Usable range

about 10 m (while in communication with FC-500) ^{*16} ^{*17}

*15: *Bluetooth* function may not be built in depending on telecommunications regulations of the country or the area where the instrument is purchased. Contact your local dealer for the details.

*16: No obstacles, few vehicles or sources of radio emissions/interference in the near vicinity of the instrument, no rain.

*17: Usage range could be shorter depending on specifications of *Bluetooth* device to communicate.

Power Supply

Power source

Rechargeable Li-ion battery BDC71

Working duration at 20 °C

Distance and angle measurement (Fine single measurement = every 30 sec.) :

BDC71:

about 10 hours

(EDM eco. mode)

BDC71:

about 14 hours

Battery state indicator

4 levels

Auto power-off

30 min/Not set (selectable)

Battery (BDC71)

Nominal voltage:

7.2V

Capacity:

2,993mAh

Dimensions:

38 (W) x 70 (D) x 20 (H) mm

Weight:

about 113 g

Charger (CDC77)	
Input voltage:	100 to 240VAC
Charging time per battery (at 25°C):	BDC71: about 4 hours (Charging can take longer than the times stated above when temperatures are either especially high or low.)
Charging temperature range:	0 to 40°C
Storage temperature range:	-20 to 65°C
Size:	94 (W) X 102 (D) X 36 (H) mm
Weight:	about 250 g

General

Display unit	LCD graphic display, 192 dots X 80 dots
GM-62:	X2 (on both sides)
GM-65:	X1 (on one side)
Backlight:	On/Off (selectable)
Operation panel (keyboard)	28 keys (soft function, operations, power on, light) with illuminator
GM-62:	X2 (on both sides)
GM-65:	X1 (on one side)
Sensitivity of levels	
Circular level:	10'2 mm
Electronic Circular levels:	Graphic display range: 6' (inner circle) Digital display range: ±6' 30"
Optical plummet	
Image:	Erect
Magnification:	3X
Minimum focus:	0.5 m
Laser plummet ^{*18}	
Signal source:	Red laser diode 635 ±10 nm (Class 2 IEC60825-1 Ed. 3.0:2014/FDA CDRH 21CFR Part 1040.10 and 1040.11 (Complies with FDA performance standards for laser products except for deviations pursuant to Laser Notice No.56, dated May 8, 2019.))
Beam accuracy:	1 mm or less (when tripod head height is 1.3 m).
Spot diameter:	ø3 mm or less
Brightness control:	5 levels
Auto power-off:	Provided (power cut off after 5 minutes)
Laser-pointer function	Provided On/Off (selectable)
Operating temperature (no condensation)	-20 to 60°C (-4 to 140°F) ^{*19}
Storage temperature range (no condensation)	-30 to 70°C (-22 to 158°F)
Dust and water resistance:	IP66 (IEC 60529: 2001)
Instrument height	192.5 mm from tribrach mounting surface 236 mm +5/-3 mm from tribrach bottom
Size (with handle)	
GM-62 (Display on both sides):	200 (W) X 181 (D) X 348 (H) mm
GM-65 (Display on one side):	200 (W) X 176 (D) X 348 (H) mm
Weight (with handle and battery)	
GM-62 (Display on both sides):	5.3 kg (11.7 lb)
GM-65 (Display on one side):	5.1 kg (11.3 lb)



***18:** Laser plummet is available as a factory option depending on the country or the area where the instrument is purchased.

***19:** No direct sunlight for using high temperatures of 50 to 60°C (122 to 140°F).

25 REGULATIONS

Region/ Country	Directives/ Regulations	Labels/Declarations
U.S.A.	FCC-Class B	<p>This device complies with part 15 of the FCC Rules. Operation is subject to the following two conditions: (1) This device may not cause harmful interference, and (2) this device must accept any interference received, including interference that may cause undesired operation.</p> <p>Responsible party: Topcon Positioning Systems, Inc. 7400 National Drive Livermore, CA 94550 USA https://www.topconpositioning.com</p> <p>FCC CAUTION Changes or modifications not expressly approved by the party responsible for compliance could void the user's authority to operate the equipment.</p> <p>Note: This equipment has been tested and found to comply with the limits for a Class B digital device, pursuant to part 15 of the FCC Rules. These limits are designed to provide reasonable protection against harmful interference in a residential installation. This equipment generates, uses and can radiate radio frequency energy and, if not installed and used in accordance with the instructions, may cause harmful interference to radio communications. However, there is no guarantee that interference will not occur in a particular installation. If this equipment does cause harmful interference to radio or television reception, which can be determined by turning the equipment off and on, the user is encouraged to try to correct the interference by one or more of the following measures:</p> <ul style="list-style-type: none"> - Reorient or relocate the receiving antenna. - Increase the separation between the equipment and receiver. - Connect the equipment into an outlet on a circuit different from that to which the receiver is connected. - Consult the dealer or an experienced radio/TV technician for help. <p>This transmitter must not be co-located or operated in conjunction with any other antenna or transmitter.</p> <p>This equipment complies with FCC radiation exposure limits set forth for an uncontrolled environment and meets the FCC radio frequency (RF) Exposure Guidelines. This equipment must be installed and operated keeping the radiator at least 20 cm or more away from person's body.</p>
California, U.S.A.	Proposition 65	<div style="border: 2px solid black; padding: 5px;"> <p>⚠ WARNING: This product can expose you to chemicals including Lead, which is known to the State of California to cause cancer and birth defects or other reproductive harm. For more information go to www.P65Warnings.ca.gov.</p> </div>
California, U.S.A.	Perchlorate Material (CR Lithium Battery)	<div style="border: 2px solid black; padding: 5px;"> <p>This product contains a CR Lithium Battery which contains Perchlorate Material-special handling may apply. See www.dtsc.ca.gov/hazardouswaste/perchlorate. Note ; This is applicable to California, U.S.A. only</p> </div>

Region/ Country	Directives/ Regulations	Labels/Declarations
California and NY, U.S.A.	Recycling Batteries	<p style="text-align: center;"><u>DON'T THROW AWAY RECHARGEABLE BATTERIES, RECYCLE THEM.</u></p> <p style="text-align: center;"><u>Topcon Positioning Systems Inc., United States Return Process for Used Rechargeable Nickel Metal Hydride, Nickel Cadmium, Small Sealed Lead Acid, and Lithium Ion, Batteries</u></p> <p>In the United States Topcon Positioning Systems Inc., has established a process by which Topcon customers may return used rechargeable Nickel Metal Hydride(Ni-MH), Nickel Cadmium(Ni-Cd), Small Sealed Lead Acid(Pb), and Lithium Ion(Li-ion) batteries to Topcon for proper recycling and disposal. Only Topcon batteries will be accepted in this process.</p> <p>Proper shipping requires that batteries or battery packs must be intact and show no signs of leaking. The metal terminals on the individual batteries must be covered with tape to prevent short circuiting and heat buildup or batteries can be placed in individual plastic bag. Battery packs should not be disassembled prior to return.</p> <p>Topcon customers are responsible for complying with all federal, state, and local regulations pertaining to packing, labeling, and shipping of batteries. Packages must include a completed return address, be prepaid by the shipper, and travel by surface mode. <u>Under no circumstance should used/recyclable batteries be shipped by air.</u></p> <p>Failure to comply with the above requirements will result in the rejection of the package at the shipper's expense.</p> <p>Please remit packages to: Topcon Positioning Systems, Inc. C/O Battery Return Dept. 150 7400 National Dr. Livermore, CA 94551</p> <p style="text-align: center;"><u>DON'T THROW AWAY RECHARGEABLE BATTERIES, RECYCLE THEM.</u></p>
Canada	ICES-Class B	<p>This class B digital apparatus complies with Canadian ICES-003.</p> <p>Cet appareil numérique de la classe B est conforme à la norme NMB-003 du Canada.</p> <p>This device contains licence-exempt transmitter(s)/receiver(s) that comply with Innovation, Science and Economic Development Canada's licence-exempt RSS(s). Operation is subject to the following two conditions:</p> <ol style="list-style-type: none"> 1. This device may not cause interference. 2. This device must accept any interference, including interference that may cause undesired operation of the device. <p>L'émetteur/récepteur exempt de licence contenu dans le présent appareil est conforme aux CNR d'Innovation, Sciences et Développement économique Canada applicables aux appareils radio exempts de licence. L'exploitation est autorisée aux deux conditions suivantes :</p> <ol style="list-style-type: none"> 1. L'appareil ne doit pas produire de brouillage; 2. L'appareil doit accepter tout brouillage radioélectrique subi, même si le brouillage est susceptible d'en compromettre le fonctionnement. <p>This equipment complies with ISSED radiation exposure limits set forth for an uncontrolled environment and meets RSS-102 of the ISSED radio frequency (RF) Exposure rules. This equipment must be installed and operated keeping the radiator at least 20 cm or more away from person's body.</p> <p>Cet équipement est conforme aux limites d'exposition aux rayonnements énoncées pour un environnement non contrôlé et respecte les règles d'exposition aux fréquences radioélectriques (RF) CNR-102 de l'ISDE. Cet équipement doit être installé et utilisé en gardant une distance de 20 cm ou plus entre le radiateur et le corps humain.</p>

Region/ Country	Directives/ Regulations	Labels/Declarations
EU/UK	EMC-Class B RE	<p>EMC NOTICE</p> <p>In industrial locations or in proximity to industrial power installations, this instrument might be affected by electromagnetic noise. Under such conditions, please test the instrument performance before use.</p> <p>This product complies with the electromagnetic environmental testing of industrial locations.</p> <p>Information on the wireless communication modules (only models equipped with the wireless function) <i>Bluetooth</i> Frequency band: 2.4 GHz, Maximum output power: +12.2 dBm</p> <p>Hereby, TOPCON CORPORATION declares that the radio equipment type of this product is in compliance with Directive 2014/53/EU. The full text of the EU declaration of conformity is available at the following internet address: https://mytopconnow.topconpositioning.com</p> <p>Manufacturer Name: TOPCON CORPORATION Address: 75-1, Hasunuma-cho, Itabashi-ku, Tokyo, 174-8580 JAPAN</p> <p>Europe Representative and Importer Name: Topcon Europe Positioning B.V. Address: Werner von Siemensstraat 35, 2712 PN Zoetermeer, The Netherlands</p> <p>UK Importer Name: Topcon Positioning (Great Britain) Ltd. Address: Unit 2 Sandy Hill Park, Sandy Way, Tamworth, Staffordshire B77 4DU U.K.</p>
EU UK	WEEE Directive The Waste Electrical and Electronic Equipment Regulations	 <p>The use of the symbol indicates that this product may not be treated as household waste. By ensuring this product is disposed of correctly, you will help prevent potential negative consequences for the environment and human health, which could otherwise be caused by inappropriate waste handling of this product. For more detailed information about the take-back and recycling of this product, please contact your supplier where you purchased the product or consult.</p>
EU UK	EU Battery Regulation The Waste Batteries and Accumulators Regulations 2009	 <p>Battery users must not dispose of batteries as unsorted general waste, but treat properly.</p> <p>If a chemical symbol is printed beneath the symbol shown above, this chemical symbol means that the battery or accumulator contains a heavy metal at a certain concentration. This will be indicated as follows: Hg: mercury(0.0005%), Cd: cadmium(0.002%), Pb: lead(0.004%)</p> <p>These ingredients may be seriously hazardous to human and the global environment.</p> <p>This product contains a coin cell. You cannot replace batteries by yourself. When you need to replace and/or dispose batteries, contact your local dealer.</p>

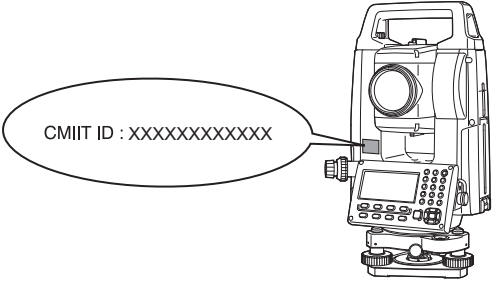
Region/ Country	Directives/ Regulations	Labels/Declarations																																																																																							
China	SRRC	<p>授權編號顯示在下列標籤上。</p> 																																																																																							
China	Chinese Environmental Directive	<table border="1" style="width: 100%; border-collapse: collapse; text-align: center;"> <thead> <tr> <th colspan="11" style="font-size: small;"><產品中有毒物質的名稱及含有的信息表></th> </tr> <tr> <th rowspan="2" style="font-size: x-small;">部件名稱</th> <th colspan="10" style="font-size: x-small;">有 害 物 質</th> </tr> <tr> <th style="font-size: x-small;">鉛 (Pb)</th> <th style="font-size: x-small;">汞 (Hg)</th> <th style="font-size: x-small;">鎘 (Cd)</th> <th style="font-size: x-small;">六價鉻 (Cr(VI))</th> <th style="font-size: x-small;">多溴聯苯 (PBBs)</th> <th style="font-size: x-small;">多溴二苯醚 (PBDEs)</th> <th style="font-size: x-small;">鄰苯二甲酸二正丁酯 (DBP)</th> <th style="font-size: x-small;">鄰苯二甲酸二異丁酯 (DIBP)</th> <th style="font-size: x-small;">鄰苯二甲酸丁基酯 (BBP)</th> <th style="font-size: x-small;">鄰苯二甲酸二(2-乙基)己酯 (DEHP)</th> </tr> </thead> <tbody> <tr> <td style="font-size: x-small;">主機部位</td> <td>×</td> <td>○</td> <td>×</td> <td>○</td> <td>○</td> <td>○</td> <td>○</td> <td>○</td> <td>○</td> <td>○</td> </tr> <tr> <td style="font-size: x-small;">電池</td> <td>○</td> <td>○</td> <td>○</td> <td>○</td> <td>○</td> <td>○</td> <td>○</td> <td>○</td> <td>○</td> <td>○</td> </tr> <tr> <td style="font-size: x-small;">充電器</td> <td>○</td> <td>○</td> <td>○</td> <td>○</td> <td>○</td> <td>○</td> <td>○</td> <td>○</td> <td>○</td> <td>○</td> </tr> <tr> <td style="font-size: x-small;">附件</td> <td>○</td> <td>○</td> <td>○</td> <td>○</td> <td>○</td> <td>○</td> <td>○</td> <td>○</td> <td>○</td> <td>○</td> </tr> <tr> <td style="font-size: x-small;">盒子</td> <td>×</td> <td>○</td> <td>○</td> <td>○</td> <td>○</td> <td>○</td> <td>○</td> <td>○</td> <td>○</td> <td>○</td> </tr> </tbody> </table> <p style="font-size: x-small;">注1：○：表示該有害物質在該部件所有均質材料中的含量均不超出電器電子產品有害物質限制使用國家標準要求。 ×：表示該有害物質至少在該部件的某一均質材料中的含量超出電器電子產品有害物質限制使用國家標準要求。 注2：以上未列出的部件，表明其有害物質含量均不超出電器電子產品有害物質限制使用國家標準要求。 This information is applicable for People's Republic of China only.</p> <div style="border: 1px solid black; padding: 5px; font-size: x-small;"> 環保使用期限標識是根據《電器電子產品有害物質限制使用管理辦法》以及《電器電子產品有害物質限制使用標識要求》(SJ/T11364) 制定的，適用於中國境內銷售的電子信息產品的標識。 只要按照安全及使用說明內容在正常使用電子信息產品情況下，從生產日期算起，在此期限內產品中含有的有毒有害物質不致發生外泄或突變，不致對環境造成嚴重污染或對其人身、財產造成嚴重損害。產品正常使用後，要廢棄在環保使用年內或者剛到年限的產品，請根據國家標準採取適當的方法進行處置。另外，此期限不同於質量/功能的保證期限。 The Mark and Information are applicable for People's Republic of China only. </div>	<產品中有毒物質的名稱及含有的信息表>											部件名稱	有 害 物 質										鉛 (Pb)	汞 (Hg)	鎘 (Cd)	六價鉻 (Cr(VI))	多溴聯苯 (PBBs)	多溴二苯醚 (PBDEs)	鄰苯二甲酸二正丁酯 (DBP)	鄰苯二甲酸二異丁酯 (DIBP)	鄰苯二甲酸丁基酯 (BBP)	鄰苯二甲酸二(2-乙基)己酯 (DEHP)	主機部位	×	○	×	○	○	○	○	○	○	○	電池	○	○	○	○	○	○	○	○	○	○	充電器	○	○	○	○	○	○	○	○	○	○	附件	○	○	○	○	○	○	○	○	○	○	盒子	×	○	○	○	○	○	○	○	○	○
<產品中有毒物質的名稱及含有的信息表>																																																																																									
部件名稱	有 害 物 質																																																																																								
	鉛 (Pb)	汞 (Hg)	鎘 (Cd)	六價鉻 (Cr(VI))	多溴聯苯 (PBBs)	多溴二苯醚 (PBDEs)	鄰苯二甲酸二正丁酯 (DBP)	鄰苯二甲酸二異丁酯 (DIBP)	鄰苯二甲酸丁基酯 (BBP)	鄰苯二甲酸二(2-乙基)己酯 (DEHP)																																																																															
主機部位	×	○	×	○	○	○	○	○	○	○																																																																															
電池	○	○	○	○	○	○	○	○	○	○																																																																															
充電器	○	○	○	○	○	○	○	○	○	○																																																																															
附件	○	○	○	○	○	○	○	○	○	○																																																																															
盒子	×	○	○	○	○	○	○	○	○	○																																																																															
Taiwan	NCC	<p>取得審驗證明之低功率射頻器材，非經核准，公司、商號或使用者均不得擅自變更頻率、加大功率或變更原設計之特性及功能。 低功率射頻器材之使用不得影響飛航安全及干擾合法通信；經發現有干擾現象時，應立即停用，並改善至無干擾時方得繼續使用。 前述合法通信，指依電信管理法規定作業之無線電通信。 低功率射頻器材須忍受合法通信或工業、科學及醫療用電波輻射性電機設備之干擾。</p> <p>內含發射器模組： CCAL17LP0890T0</p>																																																																																							
Taiwan	Taiwan Dry Cell Battery Recycling Mark	<div style="border: 1px solid black; padding: 10px;"> <p style="margin-left: 10px; font-size: small;">This product contains dry cell batteries that should be recycled. When you need to replace and/or dispose dry cell batteries, contact your dealer.</p> <p style="margin-left: 10px; font-size: x-small;">廢電池請回收</p> </div>																																																																																							

Region/ Country	Directives/ Regulations	Labels/Declarations																																									
Taiwan	Taiwan Environmental Directive	<p>設備名稱：充電器·型號：CDC77</p> <table border="1" data-bbox="484 274 1178 498"> <thead> <tr> <th rowspan="2">單元</th> <th colspan="6">限用物質及其化學符號</th> </tr> <tr> <th>鉛 (Pb)</th> <th>汞 (Hg)</th> <th>鎘 (Cd)</th> <th>六價鉻 (Cr(VI))</th> <th>多溴聯苯 (PBB)</th> <th>多溴二苯醚 (PBDE)</th> </tr> </thead> <tbody> <tr> <td>電路板</td> <td>-</td> <td>○</td> <td>○</td> <td>○</td> <td>○</td> <td>○</td> </tr> <tr> <td>外殼</td> <td>○</td> <td>○</td> <td>○</td> <td>○</td> <td>○</td> <td>○</td> </tr> <tr> <td>插頭/插座</td> <td>-</td> <td>○</td> <td>○</td> <td>○</td> <td>○</td> <td>○</td> </tr> <tr> <td>線材</td> <td>○</td> <td>○</td> <td>○</td> <td>○</td> <td>○</td> <td>○</td> </tr> </tbody> </table> <p>備考1：`超出0.1 wt %` 及 `超出0.01 wt %` 係指限用物質之百分比含量超出百分比含量基準值。</p> <p>備考2：`○` 係指該項限用物質之百分比含量未超出百分比含量基準值。</p> <p>備考3：`-` 係指該項限用物質為排除項目。</p> <p>This information is applicable for Taiwan only.</p>	單元	限用物質及其化學符號						鉛 (Pb)	汞 (Hg)	鎘 (Cd)	六價鉻 (Cr(VI))	多溴聯苯 (PBB)	多溴二苯醚 (PBDE)	電路板	-	○	○	○	○	○	外殼	○	○	○	○	○	○	插頭/插座	-	○	○	○	○	○	線材	○	○	○	○	○	○
單元	限用物質及其化學符號																																										
	鉛 (Pb)	汞 (Hg)	鎘 (Cd)	六價鉻 (Cr(VI))	多溴聯苯 (PBB)	多溴二苯醚 (PBDE)																																					
電路板	-	○	○	○	○	○																																					
外殼	○	○	○	○	○	○																																					
插頭/插座	-	○	○	○	○	○																																					
線材	○	○	○	○	○	○																																					

26 OPEN SOURCE SOFTWARE LICENSES

This product includes the open source software listed below.

26.1 Open Source Software List

This table describes any open source software used in the instruments.

Software Name	Version	License
alsa-conf-base	1.0.28-r0	LGPLv2.1 & GPLv2+
alsa-conf	1.0.28-r0	LGPLv2.1 & GPLv2+
alsa-lib	1.0.28-r0	LGPLv2.1 & GPLv2+
alsa-server	1.0.28-r0	LGPLv2.1 & GPLv2+
alsa-state	0.2.0-r5	MIT
alsa-states	0.2.0-r5	MIT
alsa-utils-aconnect	1.0.28-r1	GPLv2+
alsa-utils-alsaconf	1.0.28-r1	GPLv2+
alsa-utils-alsactl	1.0.28-r1	GPLv2+
alsa-utils-alsaloop	1.0.28-r1	GPLv2+
alsa-utils-alsamixer	1.0.28-r1	GPLv2+
alsa-utils-alsaucm	1.0.28-r1	GPLv2+
alsa-utils-amixer	1.0.28-r1	GPLv2+
alsa-utils-aplay	1.0.28-r1	GPLv2+
alsa-utils-aseqdump	1.0.28-r1	GPLv2+
alsa-utils-aseqnet	1.0.28-r1	GPLv2+
alsa-utils-iecset	1.0.28-r1	GPLv2+
alsa-utils-midi	1.0.28-r1	GPLv2+
alsa-utils-speakertest	1.0.28-r1	GPLv2+
alsa-utils	1.0.28-r1	GPLv2+
amx3-cm3	1.9.1-r2	BSD-3-Clause
arago-feed-config	1.0-r1	MIT
arago-gpl-notice	1.0-r2	MIT
base-files	3.0.14-r89	GPLv2
base-passwd	3.5.29-r0	GPLv2+
bash	3.2.48-r11	GPLv2+
bt-firmware	R8.5+git0+0c0eae241e-r10	TI-TSPA
busybox-hwclock	1.23.1-r0	GPLv2 & bzip2
busybox-syslog	1.23.1-r0	GPLv2 & bzip2
busybox-udhcp	1.23.1-r0	GPLv2 & bzip2
busybox-udhcpd-conf	1.0-r0	GPLv2 & BSD-4-Clause
busybox-udhcpd	1.23.1-r0	GPLv2 & bzip2
busybox	1.23.1-r0	GPLv2 & bzip2
ca-certificates	20141019-r0	GPL-2.0+ & MPL-2.0
cryptodev-module	1.6-r0	GPLv2
curl	7.40.0-r0	MIT
dbus-1	1.8.10-r0	GPLv2+
devmem2	1.0-r7	GPLv2+
dosfstools	2.11-r5	GPLv2
e2fsprogs-badblocks	1.42.9-r0	GPLv2
e2fsprogs-e2fsck	1.42.9-r0	GPLv2
e2fsprogs-mke2fs	1.42.9-r0	GPLv2
e2fsprogs-tune2fs	1.42.9-r0	GPLv2
e2fsprogs	1.42.9-r0	GPLv2 & LGPLv2 & BSD & MIT
ethtool	3.16-r0	GPLv2+
fbset-modes	0.1.0-r6	MIT
fbset	2.1-r4	GPLv2
i2c-tools-misc	3.1.1-r0	GPLv2+
i2c-tools	3.1.1-r0	GPLv2+
init-ifupdown	1.0-r7	GPLv2
initscript-teinetd	1.0-r0	MIT
initscripts-functions	1.0-r155	GPLv2

Software Name	Version	License
initscripts	1.0-r155	GPLv2
iperf	2.0.5-r2	BSD-3-Clause
iproute2-tc	3.17.0-r0	GPLv2+
iproute2	3.17.0-r0	GPLv2+
iptables	1.4.21-r0	GPLv2+
jpeg-tools	8d+1.4.0-r0	BSD-3-Clause
kernel-4.1.18-gbbe8cfc	4.1.18+git0+bbe8cfc1da-r22c	GPLv2
kmod	19+git0+fd56638aed-r0	GPL-2.0+ & LGPL-2.1+
libasound2	1.0.28-r0	LGPLv2.1 & GPLv2+
libattr1	2.4.47-r0	LGPLv2.1+
libblkid1	2.25.2-r1	GPLv2+ & LGPLv2.1+ & BSD
libc6	2.19-2014.08	MIT
libcap2	2.24-r0	BSD GPLv2
libcom-err2	1.42.9-r0	GPLv2 & LGPLv2 & BSD & MIT
libcurl4	7.40.0-r0	MIT
libdbus-1-3	1.8.10-r0	GPLv2+
libe2p2	1.42.9-r0	GPLv2 & LGPLv2 & BSD & MIT
libevent	2.0.21-r1	BSD
libexpat1	2.1.0-r0	MIT
libext2fs2	1.42.9-r0	GPLv2 & LGPLv2 & BSD & MIT
libffi6	3.2.1-r0	MIT
libformw5	5.9-r15.1	MIT
libfreetype6	2.5.4-r0	GPLv2+
libgcc-s1	4.9.3-r0	MIT
libglib-2.0-0	1:2.42.1-r0	LGPLv2+ & BSD & PD
libjpeg8	8d+1.4.0-r0	BSD-3-Clause
libkmod2	19+git0+fd56638aed-r0	LGPL-2.1+
liblzo2-2	2.09-r0	GPLv2+
libmenuw5	5.9-r15.1	MIT
libmount1	2.25.2-r1	GPLv2+ & LGPLv2.1+ & BSD
libncursesw5	5.9-r15.1	MIT
libnfsidmap0	0.25-r0	BSD
libopkg1	1:0.2.4-r0	GPLv2+
libpam-runtime	1.1.6-r5	GPLv2+ BSD
libpam	1.1.6-r5	GPLv2+ BSD
libpanelw5	5.9-r15.1	MIT
libpcap1	1.6.2-r0	BSD
libpcre1	8.38-r0	BSD
libperl5	5.20.0-r1	Artistic-1.0 GPL-1.0+
libpng12	1.2.52-r0	Libpng
libsamplerate0	0.1.8-r1	GPLv2+
libsmartcols1	2.25.2-r1	GPLv2+ & LGPLv2.1+ & BSD
libsndfile1	1.0.25-r2	LGPLv2.1
libss2	1.42.9-r0	GPLv2 & LGPLv2 & BSD & MIT
libssl1.0.0	1.0.2d-r0	openssl
libstdc++6	4.9.3-r0	MIT
libtic5	5.9-r15.1	MIT
libtinfo5	5.9-r15.1	MIT
libtirpc1	0.2.5-r0	BSD
libusb-1.0-0	1.0.19-r0	LGPLv2.1+
libuuid1	2.25.2-r1	GPLv2+ & LGPLv2.1+ & BSD
libwrap0	7.6-r10	BSD
libxml2	2.9.2-r0	MIT
libz1	1.2.8-r0	Zlib
modutils-initscripts	1.0-r7	PD
mtd-utils-ubifs	1.5.1+git0+9f107132a6-r0.arago0	GPLv2+
mtd-utils	1.5.1+git0+9f107132a6-r0.arago0	GPLv2+
ncurses-terminfo-base	5.9-r15.1	MIT
ncurses-terminfo	5.9-r15.1	MIT
ncurses-tools	5.9-r15.1	MIT

Software Name	Version	License
ncurses	5.9-r15.1	MIT
netbase	1:5.3-r0	GPLv2
nfs-utils-client	1.3.1-r0	MIT & GPLv2+ & BSD
openssl-conf	1.0.2d-r0	openssl
opkg-arch-config	1.0-r1	MIT
opkg	1:0.2.4-r0	GPLv2+
packagegroup-arago-base-tisdk	1.0-r16	MIT
packagegroup-arago-base	1.0-r8	MIT
packagegroup-arago-console	1.0-r12	MIT
packagegroup-core-boot	1.0-r17	MIT
pam-plugin-deny	1.1.6-r5	GPLv2+ BSD
pam-plugin-env	1.1.6-r5	GPLv2+ BSD
pam-plugin-faildelay	1.1.6-r5	GPLv2+ BSD
pam-plugin-group	1.1.6-r5	GPLv2+ BSD
pam-plugin-lastlog	1.1.6-r5	GPLv2+ BSD
pam-plugin-limits	1.1.6-r5	GPLv2+ BSD
pam-plugin-mail	1.1.6-r5	GPLv2+ BSD
pam-plugin-motd	1.1.6-r5	GPLv2+ BSD
pam-plugin-nologin	1.1.6-r5	GPLv2+ BSD
pam-plugin-permit	1.1.6-r5	GPLv2+ BSD
pam-plugin-rootok	1.1.6-r5	GPLv2+ BSD
pam-plugin-securetty	1.1.6-r5	GPLv2+ BSD
pam-plugin-shells	1.1.6-r5	GPLv2+ BSD
pam-plugin-unix	1.1.6-r5	GPLv2+ BSD
pam-plugin-warn	1.1.6-r5	GPLv2+ BSD
perl	5.20.0-r1	Artistic-1.0 GPL-1.0+
psplash-default	0.1+git0+de9979aefb-r15	GPLv2+
psplash	0.1+git0+de9979aefb-r15	GPLv2+
rpcbind	0.2.2-r0	BSD
run-postinsts	1.0-r9	MIT
shadow-base	4.2.1-r0	BSD Artistic-1.0
shadow-securetty	4.2.1-r3	MIT
shadow	4.2.1-r0	BSD Artistic-1.0
strace	4.9-r0	BSD
sysvinit-inittab	2.88dsf-r10	GPLv2
sysvinit-pidof	2.88dsf-r14	GPLv2+
sysvinit	2.88dsf-r14	GPLv2+
tcpdump	4.6.1-r0	BSD
thermal-init	1.0-r0	MIT
thttpd	2.25b-r0	BSD
udev-cache	182-r9.0	GPLv2.0+ & LGPLv2.1+
udev-extraconf	1.1-r0	MIT
udev	182-r9.0	GPLv2.0+
update-alternatives-opkg	0.1.8+git0+53274f0875-r0	GPLv2+
update-rc.d	0.7-r5	GPLv2+
usbutils-ids	007-r0	GPLv2+
usbutils	007-r0	GPLv2+
util-linux-fdisk	2.25.2-r1	GPLv2+ & LGPLv2.1+ & BSD
util-linux-fsck	2.25.2-r1	GPLv2+ & LGPLv2.1+ & BSD
util-linux-mkfs	2.25.2-r1	GPLv2+ & LGPLv2.1+ & BSD
util-linux-sfdisk	2.25.2-r1	GPLv2+ & LGPLv2.1+ & BSD
util-linux-sulogin	2.25.2-r1	GPLv2+ & LGPLv2.1+ & BSD
u-boot-ti-staging-src	2015.07+gitAUTOINC+46c915c963-r25	GPLv2+
libfuse	2.9.7	GPLv2
exFAT	1.2.7	GPLv2
tigervnc	1.8.0	GPLv2

26.2 Open Source Software Licenses

Artistic License

The "Artistic License"

Preamble

The intent of this document is to state the conditions under which a Package may be copied, such that the Copyright Holder maintains some semblance of artistic control over the development of the package, while giving the users of the package the right to use and distribute the Package in a more-or-less customary fashion, plus the right to make reasonable modifications.

Definitions:

"Package" refers to the collection of files distributed by the Copyright Holder, and derivatives of that collection of files created through textual modification.

"Standard Version" refers to such a Package if it has not been modified, or has been modified in accordance with the wishes of the Copyright Holder as specified below.

"Copyright Holder" is whoever is named in the copyright or copyrights for the package.

"You" is you, if you're thinking about copying or distributing this Package.

"Reasonable copying fee" is whatever you can justify on the basis of media cost, duplication charges, time of people involved, and so on. (You will not be required to justify it to the Copyright Holder, but only to the computing community at large as a market that must bear the fee.)

"Freely Available" means that no fee is charged for the item itself, though there may be fees involved in handling the item. It also means that recipients of the item may redistribute it under the same conditions they received it.

1. You may make and give away verbatim copies of the source form of the Standard Version of this Package without restriction, provided that you duplicate all of the original copyright notices and associated disclaimers.
2. You may apply bug fixes, portability fixes and other modifications derived from the Public Domain or from the Copyright Holder. A Package modified in such a way shall still be considered the Standard Version.
3. You may otherwise modify your copy of this Package in any way, provided that you insert a prominent notice in each changed file stating how and when you changed that file, and provided that you do at least ONE of the following:
 - a) place your modifications in the Public Domain or otherwise make them Freely Available, such as by posting said modifications to Usenet or an equivalent medium, or placing the modifications on a major archive site such as uunet.uu.net, or by allowing the Copyright Holder to include your modifications in the Standard Version of the Package.
 - b) use the modified Package only within your corporation or organization.
 - c) rename any non-standard executables so the names do not conflict with standard executables, which must also be provided, and provide a separate manual page for each non-standard executable that clearly documents how it differs from the Standard Version.
 - d) make other distribution arrangements with the Copyright Holder.
4. You may distribute the programs of this Package in object code or executable form, provided that you do at least ONE of the following:
 - a) distribute a Standard Version of the executables and library files, together with instructions (in the manual page or equivalent) on where to get the Standard Version.
 - b) accompany the distribution with the machine-readable source of the Package with your modifications.
 - c) give non-standard executables non-standard names, and clearly document the differences in manual pages (or equivalent), together with instructions on where to get the Standard Version.
 - d) make other distribution arrangements with the Copyright Holder.
5. You may charge a reasonable copying fee for any distribution of this Package. You may charge any fee you choose for support of this Package. You may not charge a fee for this Package itself. However, you may distribute this Package in aggregate with other (possibly commercial) programs as part of a larger (possibly commercial) software distribution provided that you do not advertise this Package as a product of your own. You may embed this Package's interpreter within an executable of yours (by linking); this shall be construed as a mere form of aggregation, provided that the complete Standard Version of the interpreter is so embedded.
6. The scripts and library files supplied as input to or produced as output from the programs of this Package do not automatically fall under the copyright of this Package, but belong to whoever generated them, and may be sold commercially, and may be aggregated with this Package. If such scripts or library files are aggregated with this Package via the so-called "undump" or "unexec" methods of producing a binary executable image, then distribution of such an image shall neither be construed as a distribution of this Package nor shall it fall under the restrictions of Paragraphs 3 and 4, provided that you do not represent such an executable image as a Standard Version of this Package.

7. C subroutines (or comparably compiled subroutines in other languages) supplied by you and linked into this Package in order to emulate subroutines and variables of the language defined by this Package shall not be considered part of this Package, but are the equivalent of input as in Paragraph 6, provided these subroutines do not change the language in any way that would cause it to fail the regression tests for the language.
8. Aggregation of this Package with a commercial distribution is always permitted provided that the use of this Package is embedded; that is, when no overt attempt is made to make this Package's interfaces visible to the end user of the commercial distribution. Such use shall not be construed as a distribution of this Package.
9. The name of the Copyright Holder may not be used to endorse or promote products derived from this software without specific prior written permission.
10. THIS PACKAGE IS PROVIDED "AS IS" AND WITHOUT ANY EXPRESS OR IMPLIED WARRANTIES, INCLUDING, WITHOUT LIMITATION, THE IMPLIED WARRANTIES OF MERCHANTABILITY AND FITNESS FOR A PARTICULAR PURPOSE.

The End

BSD License

The BSD License
 =====

<OWNER> = Regents of the University of California
 <ORGANIZATION> = University of California, Berkeley
 <YEAR> = 1998

In the original BSD license, both occurrences of the phrase "COPYRIGHT HOLDERS AND CONTRIBUTORS" in the disclaimer read "REGENTS AND CONTRIBUTORS".

Here is the license template:

Copyright (c) <YEAR>, <OWNER>

All rights reserved.

Redistribution and use in source and binary forms, with or without modification, are permitted provided that the following conditions are met:

- * Redistributions of source code must retain the above copyright notice, this list of conditions and the following disclaimer.
- * Redistributions in binary form must reproduce the above copyright notice, this list of conditions and the following disclaimer in the documentation and/or other materials provided with the distribution.
- * Neither the name of the <ORGANIZATION> nor the names of its contributors may be used to endorse or promote products derived from this software without specific prior written permission.

THIS SOFTWARE IS PROVIDED BY THE COPYRIGHT HOLDERS AND CONTRIBUTORS "AS IS" AND ANY EXPRESS OR IMPLIED WARRANTIES, INCLUDING, BUT NOT LIMITED TO, THE IMPLIED WARRANTIES OF MERCHANTABILITY AND FITNESS FOR A PARTICULAR PURPOSE ARE DISCLAIMED. IN NO EVENT SHALL THE COPYRIGHT HOLDER OR CONTRIBUTORS BE LIABLE FOR ANY DIRECT, INDIRECT, INCIDENTAL, SPECIAL, EXEMPLARY, OR CONSEQUENTIAL DAMAGES (INCLUDING, BUT NOT LIMITED TO, PROCUREMENT OF SUBSTITUTE GOODS OR SERVICES; LOSS OF USE, DATA, OR PROFITS; OR BUSINESS INTERRUPTION) HOWEVER CAUSED AND ON ANY THEORY OF LIABILITY, WHETHER IN CONTRACT, STRICT LIABILITY, OR TORT (INCLUDING NEGLIGENCE OR OTHERWISE) ARISING IN ANY WAY OUT OF THE USE OF THIS SOFTWARE, EVEN IF ADVISED OF THE POSSIBILITY OF SUCH DAMAGE.

BSD 2-Clause License

Redistribution and use in source and binary forms, with or without modification, are permitted provided that the following conditions are met:

1. Redistributions of source code must retain the above copyright notice, this list of conditions and the following disclaimer.
2. Redistributions in binary form must reproduce the above copyright notice, this list of conditions and the following disclaimer in the documentation and/or other materials provided with the distribution.

THIS SOFTWARE IS PROVIDED BY THE COPYRIGHT HOLDERS AND CONTRIBUTORS "AS IS" AND ANY EXPRESS OR IMPLIED WARRANTIES, INCLUDING, BUT NOT LIMITED TO, THE IMPLIED WARRANTIES OF MERCHANTABILITY AND FITNESS FOR A PARTICULAR PURPOSE ARE DISCLAIMED. IN NO EVENT SHALL THE COPYRIGHT OWNER OR CONTRIBUTORS BE LIABLE FOR ANY DIRECT, INDIRECT, INCIDENTAL, SPECIAL, EXEMPLARY, OR CONSEQUENTIAL DAMAGES (INCLUDING, BUT NOT LIMITED TO, PROCUREMENT OF SUBSTITUTE GOODS OR SERVICES; LOSS OF USE, DATA, OR PROFITS; OR BUSINESS INTERRUPTION) HOWEVER CAUSED AND ON ANY THEORY OF LIABILITY, WHETHER IN CONTRACT, STRICT LIABILITY, OR TORT (INCLUDING NEGLIGENCE OR OTHERWISE) ARISING IN ANY WAY OUT OF THE USE OF THIS SOFTWARE, EVEN IF ADVISED OF THE POSSIBILITY OF SUCH DAMAGE.

BSD 3-Clause License

Copyright (c) [year], [copyright holder]

All rights reserved.

Redistribution and use in source and binary forms, with or without modification, are permitted provided that the following conditions are met:

Redistributions of source code must retain the above copyright notice, this list of conditions and the following disclaimer.

Redistributions in binary form must reproduce the above copyright notice, this list of conditions and the following disclaimer in the documentation and/or other materials provided with the distribution.

Neither the name of the copyright holder nor the names of its contributors may be used to endorse or promote products derived from this software without specific prior written permission.

THIS SOFTWARE IS PROVIDED BY THE COPYRIGHT HOLDERS AND CONTRIBUTORS "AS IS" AND ANY EXPRESS OR IMPLIED WARRANTIES, INCLUDING, BUT NOT LIMITED TO, THE IMPLIED WARRANTIES OF MERCHANTABILITY AND FITNESS FOR A PARTICULAR PURPOSE ARE DISCLAIMED. IN NO EVENT SHALL THE COPYRIGHT HOLDER OR CONTRIBUTORS BE LIABLE FOR ANY DIRECT, INDIRECT, INCIDENTAL, SPECIAL, EXEMPLARY, OR CONSEQUENTIAL DAMAGES (INCLUDING, BUT NOT LIMITED TO, PROCUREMENT OF SUBSTITUTE GOODS OR SERVICES; LOSS OF USE, DATA, OR PROFITS; OR BUSINESS INTERRUPTION) HOWEVER CAUSED AND ON ANY THEORY OF LIABILITY, WHETHER IN CONTRACT, STRICT LIABILITY, OR TORT (INCLUDING NEGLIGENCE OR OTHERWISE) ARISING IN ANY WAY OUT OF THE USE OF THIS SOFTWARE, EVEN IF ADVISED OF THE POSSIBILITY OF SUCH DAMAGE.

bzip2 License

This program, "bzip2" and associated library "libbzip2", are copyright (C) 1996-2002 Julian R Seward. All rights reserved.

Redistribution and use in source and binary forms, with or without modification, are permitted provided that the following conditions are met:

1. Redistributions of source code must retain the above copyright notice, this list of conditions and the following disclaimer.
2. The origin of this software must not be misrepresented; you must not claim that you wrote the original software. If you use this software in a product, an acknowledgment in the product documentation would be appreciated but is not required.
3. Altered source versions must be plainly marked as such, and must not be misrepresented as being the original software.
4. The name of the author may not be used to endorse or promote products derived from this software without specific prior written permission.

THIS SOFTWARE IS PROVIDED BY THE AUTHOR "AS IS" AND ANY EXPRESS OR IMPLIED WARRANTIES, INCLUDING, BUT NOT LIMITED TO, THE IMPLIED WARRANTIES OF MERCHANTABILITY AND FITNESS FOR A PARTICULAR PURPOSE ARE DISCLAIMED. IN NO EVENT SHALL THE AUTHOR BE LIABLE FOR ANY DIRECT, INDIRECT, INCIDENTAL, SPECIAL, EXEMPLARY, OR CONSEQUENTIAL DAMAGES (INCLUDING, BUT NOT LIMITED TO, PROCUREMENT OF SUBSTITUTE GOODS OR SERVICES; LOSS OF USE, DATA, OR PROFITS; OR BUSINESS INTERRUPTION) HOWEVER CAUSED AND ON ANY THEORY OF LIABILITY, WHETHER IN CONTRACT, STRICT LIABILITY, OR TORT (INCLUDING NEGLIGENCE OR OTHERWISE) ARISING IN ANY WAY OUT OF THE USE OF THIS SOFTWARE, EVEN IF ADVISED OF THE POSSIBILITY OF SUCH DAMAGE.

Julian Seward, Cambridge, UK.
 jseward@acm.org
 bzip2/libbzip2 version 1.0.2 of 30 December 2001

GNU General Public License (GPL) V2.0

GNU GENERAL PUBLIC LICENSE
 Version 2, June 1991

Copyright (C) 1989, 1991 Free Software Foundation, Inc., 51 Franklin Street, Fifth Floor, Boston, MA 02110-1301 USA. Everyone is permitted to copy and distribute verbatim copies of this license document, but changing it is not allowed.

Preamble

The licenses for most software are designed to take away your freedom to share and change it. By contrast, the GNU General Public License is intended to guarantee your freedom to share and change free software--to make sure the software is free for all its users. This General Public License applies to most of the Free Software Foundation's software and to any other program whose authors commit to using it. (Some other Free Software Foundation software is covered by the GNU Lesser General Public License instead.) You can apply it to your programs, too.

When we speak of free software, we are referring to freedom, not price. Our General Public Licenses are designed to make sure that you have the freedom to distribute copies of free software (and charge for this service if you wish), that you receive source code or can get it if you want it, that you can change the software or use pieces of it in new free programs; and that you know you can do these things.

To protect your rights, we need to make restrictions that forbid anyone to deny you these rights or to ask you to surrender the rights. These restrictions translate to certain responsibilities for you if you distribute copies of the software, or if you modify it.

For example, if you distribute copies of such a program, whether gratis or for a fee, you must give the recipients all the rights that you have. You must make sure that they, too, receive or can get the source code. And you must show them these terms so they know their rights.

We protect your rights with two steps: (1) copyright the software, and (2) offer you this license which gives you legal permission to copy, distribute and/or modify the software.

Also, for each author's protection and ours, we want to make certain that everyone understands that there is no warranty for this free software. If the software is modified by someone else and passed on, we want its recipients to know that what they have is not the original, so that any problems introduced by others will not reflect on the original authors' reputations.

Finally, any free program is threatened constantly by software patents. We wish to avoid the danger that redistributors of a free program will individually obtain patent licenses, in effect making the program proprietary. To prevent this, we have made it clear that any patent must be licensed for everyone's free use or not licensed at all.

The precise terms and conditions for copying, distribution and modification follow.

GNU GENERAL PUBLIC LICENSE TERMS AND CONDITIONS FOR COPYING, DISTRIBUTION AND MODIFICATION

0. This License applies to any program or other work which contains a notice placed by the copyright holder saying it may be distributed under the terms of this General Public License. The "Program", below, refers to any such program or work, and a "work based on the Program" means either the Program or any derivative work under copyright law: that is to say, a work containing the Program or a portion of it, either verbatim or with modifications and/or translated into another language. (Hereinafter, translation is included without limitation in the term "modification".) Each licensee is addressed as "you".

Activities other than copying, distribution and modification are not covered by this License; they are outside its scope. The act of running the Program is not restricted, and the output from the Program is covered only if its contents constitute a work based on the Program (independent of having been made by running the Program). Whether that is true depends on what the Program does.

1. You may copy and distribute verbatim copies of the Program's source code as you receive it, in any medium, provided that you conspicuously and appropriately publish on each copy an appropriate copyright notice and disclaimer of warranty; keep intact all the notices that refer to this License and to the absence of any warranty; and give any other recipients of the Program a copy of this License along with the Program.

You may charge a fee for the physical act of transferring a copy, and you may at your option offer warranty protection in exchange for a fee.

2. You may modify your copy or copies of the Program or any portion of it, thus forming a work based on the Program, and copy and distribute such modifications or work under the terms of Section 1 above, provided that you also meet all of these conditions:

- a) You must cause the modified files to carry prominent notices stating that you changed the files and the date of any change.
- b) You must cause any work that you distribute or publish, that in whole or in part contains or is derived from the Program or any part thereof, to be licensed as a whole at no charge to all third parties under the terms of this License.
- c) If the modified program normally reads commands interactively when run, you must cause it, when started running for such interactive use in the most ordinary way, to print or display an announcement including an appropriate copyright notice and a notice that there is no warranty (or else, saying that you provide a warranty) and that users may redistribute the program under these conditions, and telling the user how to view a copy of this License. (Exception: if the Program itself is interactive but does not normally print such an announcement, your work based on the Program is not required to print an announcement.)

These requirements apply to the modified work as a whole. If identifiable sections of that work are not derived from the Program, and can be reasonably considered independent and separate works in themselves, then this License, and its terms, do not apply to those sections when you distribute them as separate works. But when you distribute the same sections as part of a whole which is a work based on the Program, the distribution of the whole must be on the terms of this License, whose permissions for other licensees extend to the entire whole, and thus to each and every part regardless of who wrote it.

Thus, it is not the intent of this section to claim rights or contest your rights to work written entirely by you; rather, the intent is to exercise the right to control the distribution of derivative or collective works based on the Program.

In addition, mere aggregation of another work not based on the Program with the Program (or with a work based on the Program) on a volume of a storage or distribution medium does not bring the other work under the scope of this License.

3. You may copy and distribute the Program (or a work based on it, under Section 2) in object code or executable form under the terms of Sections 1 and 2 above provided that you also do one of the following:
 - a) Accompany it with the complete corresponding machine-readable source code, which must be distributed under the terms of Sections 1 and 2 above on a medium customarily used for software interchange; or,
 - b) Accompany it with a written offer, valid for at least three years, to give any third party, for a charge no more than your cost of physically performing source distribution, a complete machine-readable copy of the corresponding source code, to be distributed under the terms of Sections 1 and 2 above on a medium customarily used for software interchange; or,
 - c) Accompany it with the information you received as to the offer to distribute corresponding source code. (This alternative is allowed only for noncommercial distribution and only if you received the program in object code or executable form with such an offer, in accord with Subsection b above.)

The source code for a work means the preferred form of the work for making modifications to it. For an executable work, complete source code means all the source code for all modules it contains, plus any associated interface definition files, plus the scripts used to control compilation and installation of the executable. However, as a special exception, the source code distributed need not include anything that is normally distributed (in either source or binary form) with the major components (compiler, kernel, and so on) of the operating system on which the executable runs, unless that component itself accompanies the executable.

If distribution of executable or object code is made by offering access to copy from a designated place, then offering equivalent access to copy the source code from the same place counts as distribution of the source code, even though third parties are not compelled to copy the source along with the object code.

4. You may not copy, modify, sublicense, or distribute the Program except as expressly provided under this License. Any attempt otherwise to copy, modify, sublicense or distribute the Program is void, and will automatically terminate your rights under this License. However, parties who have received copies, or rights, from you under this License will not have their licenses terminated so long as such parties remain in full compliance.
5. You are not required to accept this License, since you have not signed it. However, nothing else grants you permission to modify or distribute the Program or its derivative works. These actions are prohibited by law if you do not accept this License. Therefore, by modifying or distributing the Program (or any work based on the Program), you indicate your acceptance of this License to do so, and all its terms and conditions for copying, distributing or modifying the Program or works based on it.
6. Each time you redistribute the Program (or any work based on the Program), the recipient automatically receives a license from the original licensor to copy, distribute or modify the Program subject to these terms and conditions. You may not impose any further restrictions on the recipients' exercise of the rights granted herein. You are not responsible for enforcing compliance by third parties to this License.
7. If, as a consequence of a court judgment or allegation of patent infringement or for any other reason (not limited to patent issues), conditions are imposed on you (whether by court order, agreement or otherwise) that contradict the conditions of this License, they do not excuse you from the conditions of this License. If you cannot distribute so as to satisfy simultaneously your obligations under this License and any other pertinent obligations, then as a consequence you may not distribute the Program at all. For example, if a patent license would not permit royalty-free redistribution of the Program by all those who receive copies directly or indirectly through you, then the only way you could satisfy both it and this License would be to refrain entirely from distribution of the Program.

If any portion of this section is held invalid or unenforceable under any particular circumstance, the balance of the section is intended to apply and the section as a whole is intended to apply in other circumstances.

It is not the purpose of this section to induce you to infringe any patents or other property right claims or to contest validity of any such claims; this section has the sole purpose of protecting the integrity of the free software distribution system, which is implemented by public license practices. Many people have made generous contributions to the wide range of software distributed through that system in reliance on consistent application of that system; it is up to the author/donor to decide if he or she is willing to distribute software through any other system and a licensee cannot impose that choice.

This section is intended to make thoroughly clear what is believed to be a consequence of the rest of this License.

8. If the distribution and/or use of the Program is restricted in certain countries either by patents or by copyrighted interfaces, the original copyright holder who places the Program under this License may add an explicit geographical distribution limitation excluding those countries, so that distribution is permitted only in or among countries not thus excluded. In such case, this License incorporates the limitation as if written in the body of this License.
9. The Free Software Foundation may publish revised and/or new versions of the General Public License from time to time. Such new versions will be similar in spirit to the present version, but may differ in detail to address new problems or concerns.

Each version is given a distinguishing version number. If the Program specifies a version number of this License which applies to it and "any later version", you have the option of following the terms and conditions either of that version or of any later version published by the Free Software Foundation. If the Program does not specify a version number of this License, you may choose any version ever published by the Free Software Foundation.

10. If you wish to incorporate parts of the Program into other free programs whose distribution conditions are different, write to the author to ask for permission. For software which is copyrighted by the Free Software Foundation, write to the Free Software Foundation; we sometimes make exceptions for this. Our decision will be guided by the two goals of preserving the free status of all derivatives of our free software and of promoting the sharing and reuse of software generally.

NO WARRANTY

11. BECAUSE THE PROGRAM IS LICENSED FREE OF CHARGE, THERE IS NO WARRANTY FOR THE PROGRAM, TO THE EXTENT PERMITTED BY APPLICABLE LAW. EXCEPT WHEN OTHERWISE STATED IN WRITING THE COPYRIGHT HOLDERS AND/OR OTHER PARTIES PROVIDE THE PROGRAM "AS IS" WITHOUT WARRANTY OF ANY KIND, EITHER EXPRESSED OR IMPLIED, INCLUDING, BUT NOT LIMITED TO, THE IMPLIED WARRANTIES OF MERCHANTABILITY AND FITNESS FOR A PARTICULAR PURPOSE. THE ENTIRE RISK AS TO THE QUALITY AND PERFORMANCE OF THE PROGRAM IS WITH YOU. SHOULD THE PROGRAM PROVE DEFECTIVE, YOU ASSUME THE COST OF ALL NECESSARY SERVICING, REPAIR OR CORRECTION.
12. IN NO EVENT UNLESS REQUIRED BY APPLICABLE LAW OR AGREED TO IN WRITING WILL ANY COPYRIGHT HOLDER, OR ANY OTHER PARTY WHO MAY MODIFY AND/OR REDISTRIBUTE THE PROGRAM AS PERMITTED ABOVE, BE LIABLE TO YOU FOR DAMAGES, INCLUDING ANY GENERAL, SPECIAL, INCIDENTAL OR CONSEQUENTIAL DAMAGES ARISING OUT OF THE USE OR INABILITY TO USE THE PROGRAM (INCLUDING BUT NOT LIMITED TO LOSS OF DATA OR DATA BEING RENDERED INACCURATE OR LOSSES SUSTAINED BY YOU OR THIRD PARTIES OR A FAILURE OF THE PROGRAM TO OPERATE WITH ANY OTHER PROGRAMS), EVEN IF SUCH HOLDER OR OTHER PARTY HAS BEEN ADVISED OF THE POSSIBILITY OF SUCH DAMAGES.

END OF TERMS AND CONDITIONS

How to Apply These Terms to Your New Programs

If you develop a new program, and you want it to be of the greatest possible use to the public, the best way to achieve this is to make it free software which everyone can redistribute and change under these terms.

To do so, attach the following notices to the program. It is safest to attach them to the start of each source file to most effectively convey the exclusion of warranty; and each file should have at least the "copyright" line and a pointer to where the full notice is found.

<one line to give the program's name and a brief idea of what it does.>
Copyright (C) <year> <name of author>

This program is free software; you can redistribute it and/or modify it under the terms of the GNU General Public License as published by the Free Software Foundation; either version 2 of the License, or (at your option) any later version.

This program is distributed in the hope that it will be useful, but WITHOUT ANY WARRANTY; without even the implied warranty of MERCHANTABILITY or FITNESS FOR A PARTICULAR PURPOSE. See the GNU General Public License for more details.

You should have received a copy of the GNU General Public License along with this program; if not, write to the Free Software Foundation, Inc., 51 Franklin Street, Fifth Floor, Boston, MA 02110-1301 USA.

Also add information on how to contact you by electronic and paper mail.

If the program is interactive, make it output a short notice like this when it starts in an interactive mode:

Gnomovision version 69, Copyright (C) year name of author Gnomovision comes with ABSOLUTELY NO WARRANTY; for details type `show w'. This is free software, and you are welcome to redistribute it under certain conditions; type `show c' for details.

The hypothetical commands `show w' and `show c' should show the appropriate parts of the General Public License. Of course, the commands you use may be called something other than `show w' and `show c'; they could even be mouse-clicks or menu items--whatever suits your program.

You should also get your employer (if you work as a programmer) or your school, if any, to sign a "copyright disclaimer" for the program, if necessary. Here is a sample; alter the names:

Yoyodyne, Inc., hereby disclaims all copyright interest in the program `Gnomovision' (which makes passes at compilers) written by James Hacker.

<signature of Ty Coon>, 1 April 1989
Ty Coon, President of Vice

This General Public License does not permit incorporating your program into proprietary programs. If your program is a subroutine library, you may consider it more useful to permit linking proprietary applications with the library. If this is what you want to do, use the GNU Lesser General Public License instead of this License.

GNU General Public License (GPL) V3.0

GNU GENERAL PUBLIC LICENSE
Version 3, 29 June 2007

Copyright (C) 2007 Free Software Foundation, Inc. <<http://fsf.org/>>

Everyone is permitted to copy and distribute verbatim copies of this license document, but changing it is not allowed.

Preamble

The GNU General Public License is a free, copyleft license for software and other kinds of works.

The licenses for most software and other practical works are designed to take away your freedom to share and change the works. By contrast, the GNU General Public License is intended to guarantee your freedom to share and change all versions of a program--to make sure it remains free software for all its users. We, the Free Software Foundation, use the GNU General Public License for most of our software; it applies also to any other work released this way by its authors. You can apply it to your programs, too.

When we speak of free software, we are referring to freedom, not price. Our General Public Licenses are designed to make sure that you have the freedom to distribute copies of free software (and charge for them if you wish), that you receive source code or can get it if you want it, that you can change the software or use pieces of it in new free programs, and that you know you can do these things.

To protect your rights, we need to prevent others from denying you these rights or asking you to surrender the rights. Therefore, you have certain responsibilities if you distribute copies of the software, or if you modify it: responsibilities to respect the freedom of others.

For example, if you distribute copies of such a program, whether gratis or for a fee, you must pass on to the recipients the same freedoms that you received. You must make sure that they, too, receive or can get the source code. And you must show them these terms so they know their rights.

Developers that use the GNU GPL protect your rights with two steps: (1) assert copyright on the software, and (2) offer you this License giving you legal permission to copy, distribute and/or modify it.

For the developers' and authors' protection, the GPL clearly explains that there is no warranty for this free software. For both users' and authors' sake, the GPL requires that modified versions be marked as changed, so that their problems will not be attributed erroneously to authors of previous versions.

Some devices are designed to deny users access to install or run modified versions of the software inside them, although the manufacturer can do so. This is fundamentally incompatible with the aim of protecting users' freedom to change the software. The systematic pattern of such abuse occurs in the area of products for individuals to use, which is precisely where it is most unacceptable. Therefore, we have designed this version of the GPL to prohibit the practice for those products. If such problems arise substantially in other domains, we stand ready to extend this provision to those domains in future versions of the GPL, as needed to protect the freedom of users.

Finally, every program is threatened constantly by software patents. States should not allow patents to restrict development and use of software on general-purpose computers, but in those that do, we wish to avoid the special danger that patents applied to a free program could make it effectively proprietary. To prevent this, the GPL assures that patents cannot be used to render the program non-free.

The precise terms and conditions for copying, distribution and modification follow.

TERMS AND CONDITIONS**0. Definitions.**

"This License" refers to version 3 of the GNU General Public License.

"Copyright" also means copyright-like laws that apply to other kinds of works, such as semiconductor masks.

"The Program" refers to any copyrightable work licensed under this License. Each licensee is addressed as "you".
"Licensees" and "recipients" may be individuals or organizations.

To "modify" a work means to copy from or adapt all or part of the work in a fashion requiring copyright permission, other than the making of an exact copy. The resulting work is called a "modified version" of the earlier work or a work "based on" the earlier work.

A "covered work" means either the unmodified Program or a work based on the Program.

To "propagate" a work means to do anything with it that, without permission, would make you directly or secondarily liable for infringement under applicable copyright law, except executing it on a computer or modifying a private copy. Propagation includes copying, distribution (with or without modification), making available to the public, and in some countries other activities as well.

To "convey" a work means any kind of propagation that enables other parties to make or receive copies. Mere interaction with a user through a computer network, with no transfer of a copy, is not conveying.

An interactive user interface displays "Appropriate Legal Notices" to the extent that it includes a convenient and prominently visible feature that (1) displays an appropriate copyright notice, and (2) tells the user that there is no warranty for the work (except to the extent that warranties are provided), that licensees may convey the work under this License, and how to view a copy of this License. If the interface presents a list of user commands or options, such as a menu, a prominent item in the list meets this criterion.

1. Source Code.

The "source code" for a work means the preferred form of the work for making modifications to it. "Object code" means any non-source form of a work.

A "Standard Interface" means an interface that either is an official standard defined by a recognized standards body, or, in the case of interfaces specified for a particular programming language, one that is widely used among developers working in that language.

The "System Libraries" of an executable work include anything, other than the work as a whole, that (a) is included in the normal form of packaging a Major Component, but which is not part of that Major Component, and (b) serves only to enable use of the work with that Major Component, or to implement a Standard Interface for which an implementation is available to the public in source code form.

A "Major Component", in this context, means a major essential component (kernel, window system, and so on) of the specific operating system (if any) on which the executable work runs, or a compiler used to produce the work, or an object code interpreter used to run it.

The "Corresponding Source" for a work in object code form means all the source code needed to generate, install, and (for an executable work) run the object code and to modify the work, including scripts to control those activities. However, it does not include the work's System Libraries, or general-purpose tools or generally available free programs which are used unmodified in performing those activities but which are not part of the work. For example, Corresponding Source includes interface definition files associated with source files for the work, and the source code for shared libraries and dynamically linked subprograms that the work is specifically designed to require, such as by intimate data communication or control flow between those subprograms and other parts of the work.

The Corresponding Source need not include anything that users can regenerate automatically from other parts of the Corresponding Source.

The Corresponding Source for a work in source code form is that same work.

2. Basic Permissions.

All rights granted under this License are granted for the term of copyright on the Program, and are irrevocable provided the stated conditions are met. This License explicitly affirms your unlimited permission to run the unmodified Program. The output from running a covered work is covered by this License only if the output, given its content, constitutes a covered work. This License acknowledges your rights of fair use or other equivalent, as provided by copyright law.

You may make, run and propagate covered works that you do not convey, without conditions so long as your license otherwise remains in force. You may convey covered works to others for the sole purpose of having them make modifications exclusively for you, or provide you with facilities for running those works, provided that you comply with the terms of this License in conveying all material for which you do not control copyright. Those thus making or running the covered works for you must do so exclusively on your behalf, under your direction and control, on terms that prohibit them from making any copies of your copyrighted material outside their relationship with you.

Conveying under any other circumstances is permitted solely under the conditions stated below. Sublicensing is not allowed; section 10 makes it unnecessary.

3. Protecting Users' Legal Rights From Anti-Circumvention Law.

No covered work shall be deemed part of an effective technological measure under any applicable law fulfilling obligations under article 11 of the WIPO copyright treaty adopted on 20 December 1996, or similar laws prohibiting or restricting circumvention of such measures.

When you convey a covered work, you waive any legal power to forbid circumvention of technological measures to the extent such circumvention is effected by exercising rights under this License with respect to the covered work, and you disclaim any intention to limit operation or modification of the work as a means of enforcing, against the work's users, your or third parties' legal rights to forbid circumvention of technological measures.

4. Conveying Verbatim Copies.

You may convey verbatim copies of the Program's source code as you receive it, in any medium, provided that you conspicuously and appropriately publish on each copy an appropriate copyright notice; keep intact all notices stating that this License and any non-permissive terms added in accord with section 7 apply to the code; keep intact all notices of the absence of any warranty; and give all recipients a copy of this License along with the Program.

You may charge any price or no price for each copy that you convey, and you may offer support or warranty protection for a fee.

5. Conveying Modified Source Versions.

You may convey a work based on the Program, or the modifications to produce it from the Program, in the form of source code under the terms of section 4, provided that you also meet all of these conditions:

- a) The work must carry prominent notices stating that you modified it, and giving a relevant date.
- b) The work must carry prominent notices stating that it is released under this License and any conditions added under section 7. This requirement modifies the requirement in section 4 to "keep intact all notices".
- c) You must license the entire work, as a whole, under this License to anyone who comes into possession of a copy. This License will therefore apply, along with any applicable section 7 additional terms, to the whole of the work, and all its parts, regardless of how they are packaged. This License gives no permission to license the work in any other way, but it does not invalidate such permission if you have separately received it.
- d) If the work has interactive user interfaces, each must display Appropriate Legal Notices; however, if the Program has interactive interfaces that do not display Appropriate Legal Notices, your work need not make them do so.

A compilation of a covered work with other separate and independent works, which are not by their nature extensions of the covered work, and which are not combined with it such as to form a larger program, in or on a volume of a storage or distribution medium, is called an "aggregate" if the compilation and its resulting copyright are not used to limit the access or legal rights of the compilation's users beyond what the individual works permit. Inclusion of a covered work in an aggregate does not cause this License to apply to the other parts of the aggregate.

6. Conveying Non-Source Forms.

You may convey a covered work in object code form under the terms of sections 4 and 5, provided that you also convey the machine-readable Corresponding Source under the terms of this License, in one of these ways:

- a) Convey the object code in, or embodied in, a physical product (including a physical distribution medium), accompanied by the Corresponding Source fixed on a durable physical medium customarily used for software interchange.
- b) Convey the object code in, or embodied in, a physical product (including a physical distribution medium), accompanied by a written offer, valid for at least three years and valid for as long as you offer spare parts or customer support for that product model, to give anyone who possesses the object code either (1) a copy of the Corresponding Source for all the software in the product that is covered by this License, on a durable physical medium customarily used for software interchange, for a price no more than your reasonable cost of physically performing this conveying of source, or (2) access to copy the Corresponding Source from a network server at no charge.
- c) Convey individual copies of the object code with a copy of the written offer to provide the Corresponding Source. This alternative is allowed only occasionally and noncommercially, and only if you received the object code with such an offer, in accord with subsection 6b.
- d) Convey the object code by offering access from a designated place (gratis or for a charge), and offer equivalent access to the Corresponding Source in the same way through the same place at no further charge. You need not require recipients to copy the Corresponding Source along with the object code. If the place to copy the object code is a network server, the Corresponding Source may be on a different server (operated by you or a third party) that supports equivalent copying facilities, provided you maintain clear directions next to the object code saying where to find the Corresponding Source. Regardless of what server hosts the Corresponding Source, you remain obligated to ensure that it is available for as long as needed to satisfy these requirements.
- e) Convey the object code using peer-to-peer transmission, provided you inform other peers where the object code and Corresponding Source of the work are being offered to the general public at no charge under subsection 6d.

A separable portion of the object code, whose source code is excluded from the Corresponding Source as a System Library, need not be included in conveying the object code work.

A "User Product" is either (1) a "consumer product", which means any tangible personal property which is normally used for personal, family, or household purposes, or (2) anything designed or sold for incorporation into a dwelling. In determining whether a product is a consumer product, doubtful cases shall be resolved in favor of coverage. For a particular product received by a particular user, "normally used" refers to a typical or common use of that class of product, regardless of the status of the particular user or of the way in which the particular user actually uses, or expects or is expected to use, the product. A product is a consumer product regardless of whether the product has substantial commercial, industrial or non-consumer uses, unless such uses represent the only significant mode of use of the product.

"Installation Information" for a User Product means any methods, procedures, authorization keys, or other information required to install and execute modified versions of a covered work in that User Product from a modified version of its Corresponding Source. The information must suffice to ensure that the continued functioning of the modified object code is in no case prevented or interfered with solely because modification has been made.

If you convey an object code work under this section in, or with, or specifically for use in, a User Product, and the conveying occurs as part of a transaction in which the right of possession and use of the User Product is transferred to the recipient in perpetuity or for a fixed term (regardless of how the transaction is characterized), the Corresponding Source conveyed under this section must be accompanied by the Installation Information. But this requirement does not apply if neither you nor any third party retains the ability to install modified object code on the User Product (for example, the work has been installed in ROM).

The requirement to provide Installation Information does not include a requirement to continue to provide support service, warranty, or updates for a work that has been modified or installed by the recipient, or for the User Product in which it has been modified or installed. Access to a network may be denied when the modification itself materially and adversely affects the operation of the network or violates the rules and protocols for communication across the network.

Corresponding Source conveyed, and Installation Information provided, in accord with this section must be in a format that is publicly documented (and with an implementation available to the public in source code form), and must require no special password or key for unpacking, reading or copying.

7. Additional Terms.

"Additional permissions" are terms that supplement the terms of this License by making exceptions from one or more of its conditions. Additional permissions that are applicable to the entire Program shall be treated as though they were included in this License, to the extent that they are valid under applicable law. If additional permissions apply only to part of the Program, that part may be used separately under those permissions, but the entire Program remains governed by this License without regard to the additional permissions.

When you convey a copy of a covered work, you may at your option remove any additional permissions from that copy, or from any part of it. (Additional permissions may be written to require their own removal in certain cases when you modify the work.) You may place additional permissions on material, added by you to a covered work, for which you have or can give appropriate copyright permission.

Notwithstanding any other provision of this License, for material you add to a covered work, you may (if authorized by the copyright holders of that material) supplement the terms of this License with terms:

- a) Disclaiming warranty or limiting liability differently from the terms of sections 15 and 16 of this License; or
- b) Requiring preservation of specified reasonable legal notices or author attributions in that material or in the Appropriate Legal Notices displayed by works containing it; or
- c) Prohibiting misrepresentation of the origin of that material, or requiring that modified versions of such material be marked in reasonable ways as different from the original version; or
- d) Limiting the use for publicity purposes of names of licensors or authors of the material; or
- e) Declining to grant rights under trademark law for use of some trade names, trademarks, or service marks; or
- f) Requiring indemnification of licensors and authors of that material by anyone who conveys the material (or modified versions of it) with contractual assumptions of liability to the recipient, for any liability that these contractual assumptions directly impose on those licensors and authors.

All other non-permissive additional terms are considered "further restrictions" within the meaning of section 10. If the Program as you received it, or any part of it, contains a notice stating that it is governed by this License along with a term that is a further restriction, you may remove that term. If a license document contains a further restriction but permits relicensing or conveying under this License, you may add to a covered work material governed by the terms of that license document, provided that the further restriction does not survive such relicensing or conveying.

If you add terms to a covered work in accord with this section, you must place, in the relevant source files, a statement of the additional terms that apply to those files, or a notice indicating where to find the applicable terms.

Additional terms, permissive or non-permissive, may be stated in the form of a separately written license, or stated as exceptions; the above requirements apply either way.

8. Termination.

You may not propagate or modify a covered work except as expressly provided under this License. Any attempt otherwise to propagate or modify it is void, and will automatically terminate your rights under this License (including any patent licenses granted under the third paragraph of section 11).

However, if you cease all violation of this License, then your license from a particular copyright holder is reinstated (a) provisionally, unless and until the copyright holder explicitly and finally terminates your license, and (b) permanently, if the copyright holder fails to notify you of the violation by some reasonable means prior to 60 days after the cessation.

Moreover, your license from a particular copyright holder is reinstated permanently if the copyright holder notifies you of the violation by some reasonable means, this is the first time you have received notice of violation of this License (for any work) from that copyright holder, and you cure the violation prior to 30 days after your receipt of the notice.

Termination of your rights under this section does not terminate the licenses of parties who have received copies or rights from you under this License. If your rights have been terminated and not permanently reinstated, you do not qualify to receive new licenses for the same material under section 10.

9. Acceptance Not Required for Having Copies.

You are not required to accept this License in order to receive or run a copy of the Program. Ancillary propagation of a covered work occurring solely as a consequence of using peer-to-peer transmission to receive a copy likewise does not require acceptance. However, nothing other than this License grants you permission to propagate or modify any covered work. These actions infringe copyright if you do not accept this License. Therefore, by modifying or propagating a covered work, you indicate your acceptance of this License to do so.

10. Automatic Licensing of Downstream Recipients.

Each time you convey a covered work, the recipient automatically receives a license from the original licensors, to run, modify and propagate that work, subject to this License. You are not responsible for enforcing compliance by third parties with this License.

An "entity transaction" is a transaction transferring control of an organization, or substantially all assets of one, or subdividing an organization, or merging organizations. If propagation of a covered work results from an entity transaction, each party to that transaction who receives a copy of the work also receives whatever licenses to the work the party's predecessor in interest had or could give under the previous paragraph, plus a right to possession of the Corresponding Source of the work from the predecessor in interest, if the predecessor has it or can get it with reasonable efforts.

You may not impose any further restrictions on the exercise of the rights granted or affirmed under this License. For example, you may not impose a license fee, royalty, or other charge for exercise of rights granted under this License, and you may not initiate litigation (including a cross-claim or counterclaim in a lawsuit) alleging that any patent claim is infringed by making, using, selling, offering for sale, or importing the Program or any portion of it.

11. Patents.

A "contributor" is a copyright holder who authorizes use under this License of the Program or a work on which the Program is based. The work thus licensed is called the contributor's "contributor version".

A contributor's "essential patent claims" are all patent claims owned or controlled by the contributor, whether already acquired or hereafter acquired, that would be infringed by some manner, permitted by this License, of making, using, or selling its contributor version, but do not include claims that would be infringed only as a consequence of further modification of the contributor version. For purposes of this definition, "control" includes the right to grant patent sublicenses in a manner consistent with the requirements of this License.

Each contributor grants you a non-exclusive, worldwide, royalty-free patent license under the contributor's essential patent claims, to make, use, sell, offer for sale, import and otherwise run, modify and propagate the contents of its contributor version.

In the following three paragraphs, a "patent license" is any express agreement or commitment, however denominated, not to enforce a patent (such as an express permission to practice a patent or covenant not to sue for patent infringement). To "grant" such a patent license to a party means to make such an agreement or commitment not to enforce a patent against the party.

If you convey a covered work, knowingly relying on a patent license, and the Corresponding Source of the work is not available for anyone to copy, free of charge and under the terms of this License, through a publicly available network server or other readily accessible means, then you must either (1) cause the Corresponding Source to be so available, or (2) arrange to deprive yourself of the benefit of the patent license for this particular work, or (3) arrange, in a manner consistent with the requirements of this License, to extend the patent license to downstream recipients. "Knowingly relying" means you have actual knowledge that, but for the patent license, your conveying the covered work in a country, or your recipient's use of the covered work in a country, would infringe one or more identifiable patents in that country that you have reason to believe are valid.

If, pursuant to or in connection with a single transaction or arrangement, you convey, or propagate by procuring conveyance of, a covered work, and grant a patent license to some of the parties receiving the covered work authorizing them to use, propagate, modify or convey a specific copy of the covered work, then the patent license you grant is automatically extended to all recipients of the covered work and works based on it.

A patent license is "discriminatory" if it does not include within the scope of its coverage, prohibits the exercise of, or is conditioned on the non-exercise of one or more of the rights that are specifically granted under this License. You may not convey a covered work if you are a party to an arrangement with a third party that is in the business of distributing software, under which you make payment to the third party based on the extent of your activity of conveying the work, and under which the third party grants, to any of the parties who would receive the covered work from you, a discriminatory patent license (a) in connection with copies of the covered work conveyed by you (or copies made from those copies), or (b) primarily for and in connection with specific products or compilations that contain the covered work, unless you entered into that arrangement, or that patent license was granted, prior to 28 March 2007.

Nothing in this License shall be construed as excluding or limiting any implied license or other defenses to infringement that may otherwise be available to you under applicable patent law.

12. No Surrender of Others' Freedom.

If conditions are imposed on you (whether by court order, agreement or otherwise) that contradict the conditions of this License, they do not excuse you from the conditions of this License. If you cannot convey a covered work so as to satisfy simultaneously your obligations under this License and any other pertinent obligations, then as a consequence you may not convey it at all. For example, if you agree to terms that obligate you to collect a royalty for further conveying from those to whom you convey the Program, the only way you could satisfy both those terms and this License would be to refrain entirely from conveying the Program.

13. Use with the GNU Affero General Public License.

Notwithstanding any other provision of this License, you have permission to link or combine any covered work with a work licensed under version 3 of the GNU Affero General Public License into a single combined work, and to convey the resulting work. The terms of this License will continue to apply to the part which is the covered work, but the special requirements of the GNU Affero General Public License, section 13, concerning interaction through a network will apply to the combination as such.

14. Revised Versions of this License.

The Free Software Foundation may publish revised and/or new versions of the GNU General Public License from time to time. Such new versions will be similar in spirit to the present version, but may differ in detail to address new problems or concerns.

Each version is given a distinguishing version number. If the Program specifies that a certain numbered version of the GNU General Public License "or any later version" applies to it, you have the option of following the terms and conditions either of that numbered version or of any later version published by the Free Software Foundation. If the Program does not specify a version number of the GNU General Public License, you may choose any version ever published by the Free Software Foundation.

If the Program specifies that a proxy can decide which future versions of the GNU General Public License can be used, that proxy's public statement of acceptance of a version permanently authorizes you to choose that version for the Program.

Later license versions may give you additional or different permissions. However, no additional obligations are imposed on any author or copyright holder as a result of your choosing to follow a later version.

15. Disclaimer of Warranty.

THERE IS NO WARRANTY FOR THE PROGRAM, TO THE EXTENT PERMITTED BY APPLICABLE LAW. EXCEPT WHEN OTHERWISE STATED IN WRITING THE COPYRIGHT HOLDERS AND/OR OTHER PARTIES PROVIDE THE PROGRAM "AS IS" WITHOUT WARRANTY OF ANY KIND, EITHER EXPRESSED OR IMPLIED, INCLUDING, BUT NOT LIMITED TO, THE IMPLIED WARRANTIES OF MERCHANTABILITY AND FITNESS FOR A PARTICULAR PURPOSE. THE ENTIRE RISK AS TO THE QUALITY AND PERFORMANCE OF THE PROGRAM IS WITH YOU. SHOULD THE PROGRAM PROVE DEFECTIVE, YOU ASSUME THE COST OF ALL NECESSARY SERVICING, REPAIR OR CORRECTION.

16. Limitation of Liability.

IN NO EVENT UNLESS REQUIRED BY APPLICABLE LAW OR AGREED TO IN WRITING WILL ANY COPYRIGHT HOLDER, OR ANY OTHER PARTY WHO MODIFIES AND/OR CONVEYS THE PROGRAM AS PERMITTED ABOVE, BE LIABLE TO YOU FOR DAMAGES, INCLUDING ANY GENERAL, SPECIAL, INCIDENTAL OR CONSEQUENTIAL DAMAGES ARISING OUT OF THE USE OR INABILITY TO USE THE PROGRAM (INCLUDING BUT NOT LIMITED TO LOSS OF DATA OR DATA BEING RENDERED INACCURATE OR LOSSES SUSTAINED BY YOU OR THIRD PARTIES OR A FAILURE OF THE PROGRAM TO OPERATE WITH ANY OTHER PROGRAMS), EVEN IF SUCH HOLDER OR OTHER PARTY HAS BEEN ADVISED OF THE POSSIBILITY OF SUCH DAMAGES.

17. Interpretation of Sections 15 and 16.

If the disclaimer of warranty and limitation of liability provided above cannot be given local legal effect according to their terms, reviewing courts shall apply local law that most closely approximates an absolute waiver of all civil liability in connection with the Program, unless a warranty or assumption of liability accompanies a copy of the Program in return for a fee.

END OF TERMS AND CONDITIONS

How to Apply These Terms to Your New Programs

If you develop a new program, and you want it to be of the greatest possible use to the public, the best way to achieve this is to make it free software which everyone can redistribute and change under these terms.

To do so, attach the following notices to the program. It is safest to attach them to the start of each source file to most effectively state the exclusion of warranty; and each file should have at least the "copyright" line and a pointer to where the full notice is found.

```
<one line to give the program's name and a brief idea of what it does.>
Copyright (C) <year> <name of author>
```

This program is free software: you can redistribute it and/or modify it under the terms of the GNU General Public License as published by the Free Software Foundation, either version 3 of the License, or (at your option) any later version.

This program is distributed in the hope that it will be useful, but WITHOUT ANY WARRANTY; without even the implied warranty of MERCHANTABILITY or FITNESS FOR A PARTICULAR PURPOSE. See the GNU General Public License for more details.

You should have received a copy of the GNU General Public License along with this program. If not, see <<http://www.gnu.org/licenses/>>.

Also add information on how to contact you by electronic and paper mail.

If the program does terminal interaction, make it output a short notice like this when it starts in an interactive mode:

```
<program> Copyright (C) <year> <name of author>
This program comes with ABSOLUTELY NO WARRANTY; for details type `show w'.
This is free software, and you are welcome to redistribute it under certain conditions; type `show c' for details.
```

The hypothetical commands `show w' and `show c' should show the appropriate parts of the General Public License. Of course, your program's commands might be different; for a GUI interface, you would use an "about box".

You should also get your employer (if you work as a programmer) or school, if any, to sign a "copyright disclaimer" for the program, if necessary. For more information on this, and how to apply and follow the GNU GPL, see <<http://www.gnu.org/licenses/>>.

The GNU General Public License does not permit incorporating your program into proprietary programs. If your program is a subroutine library, you may consider it more useful to permit linking proprietary applications with the library. If this is what you want to do, use the GNU Lesser General Public License instead of this License. But first, please read <<http://www.gnu.org/philosophy/why-not-lgpl.html>>.

GNU Library General Public License (LGPL) V2.0

GNU LIBRARY GENERAL PUBLIC LICENSE
Version 2, June 1991

Copyright (C) 1991 Free Software Foundation, Inc. 51 Franklin Street, Fifth Floor, Boston, MA 02110-1301 USA
Everyone is permitted to copy and distribute verbatim copies of this license document, but changing it is not allowed.

[This is the first released version of the library GPL. It is numbered 2 because it goes with version 2 of the ordinary GPL.]

Preamble

The licenses for most software are designed to take away your freedom to share and change it. By contrast, the GNU General Public Licenses are intended to guarantee your freedom to share and change free software—to make sure the software is free for all its users.

This license, the Library General Public License, applies to some specially designated Free Software Foundation software, and to any other libraries whose authors decide to use it. You can use it for your libraries, too.

When we speak of free software, we are referring to freedom, not price. Our General Public Licenses are designed to make sure that you have the freedom to distribute copies of free software (and charge for this service if you wish), that you receive source code or can get it if you want it, that you can change the software or use pieces of it in new free programs; and that you know you can do these things.

To protect your rights, we need to make restrictions that forbid anyone to deny you these rights or to ask you to surrender the rights. These restrictions translate to certain responsibilities for you if you distribute copies of the library, or if you modify it.

For example, if you distribute copies of the library, whether gratis or for a fee, you must give the recipients all the rights that we gave you. You must make sure that they, too, receive or can get the source code. If you link a program with the library, you must provide complete object files to the recipients so that they can relink them with the library, after making changes to the library and recompiling it. And you must show them these terms so they know their rights.

Our method of protecting your rights has two steps: (1) copyright the library, and (2) offer you this license which gives you legal permission to copy, distribute and/or modify the library.

Also, for each distributor's protection, we want to make certain that everyone understands that there is no warranty for this free library. If the library is modified by someone else and passed on, we want its recipients to know that what they have is not the original version, so that any problems introduced by others will not reflect on the original authors' reputations.

Finally, any free program is threatened constantly by software patents. We wish to avoid the danger that companies distributing free software will individually obtain patent licenses, thus in effect transforming the program into proprietary software. To prevent this, we have made it clear that any patent must be licensed for everyone's free use or not licensed at all.

Most GNU software, including some libraries, is covered by the ordinary GNU General Public License, which was designed for utility programs. This license, the GNU Library General Public License, applies to certain designated libraries. This license is quite different from the ordinary one; be sure to read it in full, and don't assume that anything in it is the same as in the ordinary license.

The reason we have a separate public license for some libraries is that they blur the distinction we usually make between modifying or adding to a program and simply using it. Linking a program with a library, without changing the library, is in some sense simply using the library, and is analogous to running a utility program or application program. However, in a textual and legal sense, the linked executable is a combined work, a derivative of the original library, and the ordinary General Public License treats it as such.

Because of this blurred distinction, using the ordinary General Public License for libraries did not effectively promote software sharing, because most developers did not use the libraries. We concluded that weaker conditions might promote sharing better.

However, unrestricted linking of non-free programs would deprive the users of those programs of all benefit from the free status of the libraries themselves. This Library General Public License is intended to permit developers of non-free programs to use free libraries, while preserving your freedom as a user of such programs to change the free libraries that are incorporated in them. (We have not seen how to achieve this as regards changes in header files, but we have achieved it as regards changes in the actual functions of the Library.) The hope is that this will lead to faster development of free libraries.

The precise terms and conditions for copying, distribution and modification follow. Pay close attention to the difference between a "work based on the library" and a "work that uses the library". The former contains code derived from the library, while the latter only works together with the library.

Note that it is possible for a library to be covered by the ordinary General Public License rather than by this special one.

GNU LIBRARY GENERAL PUBLIC LICENSE
TERMS AND CONDITIONS FOR COPYING, DISTRIBUTION AND MODIFICATION

0. This License Agreement applies to any software library which contains a notice placed by the copyright holder or other authorized party saying it may be distributed under the terms of this Library General Public License (also called "this License"). Each licensee is addressed as "you".

A "library" means a collection of software functions and/or data prepared so as to be conveniently linked with application programs (which use some of those functions and data) to form executables.

The "Library", below, refers to any such software library or work which has been distributed under these terms. A "work based on the Library" means either the Library or any derivative work under copyright law: that is to say, a work containing the Library or a portion of it, either verbatim or with modifications and/or translated straightforwardly into another language. (Hereinafter, translation is included without limitation in the term "modification".)

"Source code" for a work means the preferred form of the work for making modifications to it. For a library, complete source code means all the source code for all modules it contains, plus any associated interface definition files, plus the scripts used to control compilation and installation of the library.

Activities other than copying, distribution and modification are not covered by this License; they are outside its scope. The act of running a program using the Library is not restricted, and output from such a program is covered only if its contents constitute a work based on the Library (independent of the use of the Library in a tool for writing it). Whether that is true depends on what the Library does and what the program that uses the Library does.

1. You may copy and distribute verbatim copies of the Library's complete source code as you receive it, in any medium, provided that you conspicuously and appropriately publish on each copy an appropriate copyright notice and disclaimer of warranty; keep intact all the notices that refer to this License and to the absence of any warranty; and distribute a copy of this License along with the Library.

You may charge a fee for the physical act of transferring a copy, and you may at your option offer warranty protection in exchange for a fee.

2. You may modify your copy or copies of the Library or any portion of it, thus forming a work based on the Library, and copy and distribute such modifications or work under the terms of Section 1 above, provided that you also meet all of these conditions:
- a) The modified work must itself be a software library.
 - b) You must cause the files modified to carry prominent notices stating that you changed the files and the date of any change.
 - c) You must cause the whole of the work to be licensed at no charge to all third parties under the terms of this License.
 - d) If a facility in the modified Library refers to a function or a table of data to be supplied by an application program that uses the facility, other than as an argument passed when the facility is invoked, then you must make a good faith effort to ensure that, in the event an application does not supply such function or table, the facility still operates, and performs whatever part of its purpose remains meaningful.

(For example, a function in a library to compute square roots has a purpose that is entirely well-defined independent of the application. Therefore, Subsection 2d requires that any application-supplied function or table used by this function must be optional: if the application does not supply it, the square root function must still compute square roots.)

These requirements apply to the modified work as a whole. If identifiable sections of that work are not derived from the Library, and can be reasonably considered independent and separate works in themselves, then this License, and its terms, do not apply to those sections when you distribute them as separate works. But when you distribute the same sections as part of a whole which is a work based on the Library, the distribution of the whole must be on the terms of this License, whose permissions for other licensees extend to the entire whole, and thus to each and every part regardless of who wrote it.

Thus, it is not the intent of this section to claim rights or contest your rights to work written entirely by you; rather, the intent is to exercise the right to control the distribution of derivative or collective works based on the Library.

In addition, mere aggregation of another work not based on the Library with the Library (or with a work based on the Library) on a volume of a storage or distribution medium does not bring the other work under the scope of this License.

3. You may opt to apply the terms of the ordinary GNU General Public License instead of this License to a given copy of the Library. To do this, you must alter all the notices that refer to this License, so that they refer to the ordinary GNU General Public License, version 2, instead of to this License. (If a newer version than version 2 of the ordinary GNU General Public License has appeared, then you can specify that version instead if you wish.) Do not make any other change in these notices.

Once this change is made in a given copy, it is irreversible for that copy, so the ordinary GNU General Public License applies to all subsequent copies and derivative works made from that copy.

This option is useful when you wish to copy part of the code of the Library into a program that is not a library.

4. You may copy and distribute the Library (or a portion or derivative of it, under Section 2) in object code or executable form under the terms of Sections 1 and 2 above provided that you accompany it with the complete corresponding machine-readable source code, which must be distributed under the terms of Sections 1 and 2 above on a medium customarily used for software interchange.

If distribution of object code is made by offering access to copy from a designated place, then offering equivalent access to copy the source code from the same place satisfies the requirement to distribute the source code, even though third parties are not compelled to copy the source along with the object code.

5. A program that contains no derivative of any portion of the Library, but is designed to work with the Library by being compiled or linked with it, is called a "work that uses the Library". Such a work, in isolation, is not a derivative work of the Library, and therefore falls outside the scope of this License.

However, linking a "work that uses the Library" with the Library creates an executable that is a derivative of the Library (because it contains portions of the Library), rather than a "work that uses the library". The executable is therefore covered by this License. Section 6 states terms for distribution of such executables.

When a "work that uses the Library" uses material from a header file that is part of the Library, the object code for the work may be a derivative work of the Library even though the source code is not. Whether this is true is especially significant if the work can be linked without the Library, or if the work is itself a library. The threshold for this to be true is not precisely defined by law.

If such an object file uses only numerical parameters, data structure layouts and accessors, and small macros and small inline functions (ten lines or less in length), then the use of the object file is unrestricted, regardless of whether it is legally a derivative work. (Executables containing this object code plus portions of the Library will still fall under Section 6.)

Otherwise, if the work is a derivative of the Library, you may distribute the object code for the work under the terms of Section 6. Any executables containing that work also fall under Section 6, whether or not they are linked directly with the Library itself.

6. As an exception to the Sections above, you may also compile or link a "work that uses the Library" with the Library to produce a work containing portions of the Library, and distribute that work under terms of your choice, provided that the terms permit modification of the work for the customer's own use and reverse engineering for debugging such modifications.

You must give prominent notice with each copy of the work that the Library is used in it and that the Library and its use are covered by this License. You must supply a copy of this License. If the work during execution displays copyright notices, you must include the copyright notice for the Library among them, as well as a reference directing the user to the copy of this License. Also, you must do one of these things:

- a) Accompany the work with the complete corresponding machine-readable source code for the Library including whatever changes were used in the work (which must be distributed under Sections 1 and 2 above); and, if the work is an executable linked with the Library, with the complete machine-readable "work that uses the Library", as object code and/or source code, so that the user can modify the Library and then relink to produce a modified executable containing the modified Library. (It is understood that the user who changes the contents of definitions files in the Library will not necessarily be able to recompile the application to use the modified definitions.)
- b) Accompany the work with a written offer, valid for at least three years, to give the same user the materials specified in Subsection 6a, above, for a charge no more than the cost of performing this distribution.
- c) If distribution of the work is made by offering access to copy from a designated place, offer equivalent access to copy the above specified materials from the same place.
- d) Verify that the user has already received a copy of these materials or that you have already sent this user a copy.

For an executable, the required form of the "work that uses the Library" must include any data and utility programs needed for reproducing the executable from it. However, as a special exception, the source code distributed need not include anything that is normally distributed (in either source or binary form) with the major components (compiler, kernel, and so on) of the operating system on which the executable runs, unless that component itself accompanies the executable.

It may happen that this requirement contradicts the license restrictions of other proprietary libraries that do not normally accompany the operating system. Such a contradiction means you cannot use both them and the Library together in an executable that you distribute.

7. You may place library facilities that are a work based on the Library side-by-side in a single library together with other library facilities not covered by this License, and distribute such a combined library, provided that the separate distribution of the work based on the Library and of the other library facilities is otherwise permitted, and provided that you do these two things:
 - a) Accompany the combined library with a copy of the same work based on the Library, uncombined with any other library facilities. This must be distributed under the terms of the Sections above.
 - b) Give prominent notice with the combined library of the fact that part of it is a work based on the Library, and explaining where to find the accompanying uncombined form of the same work.
8. You may not copy, modify, sublicense, link with, or distribute the Library except as expressly provided under this License. Any attempt otherwise to copy, modify, sublicense, link with, or distribute the Library is void, and will automatically terminate your rights under this License. However, parties who have received copies, or rights, from you under this License will not have their licenses terminated so long as such parties remain in full compliance.

9. You are not required to accept this License, since you have not signed it. However, nothing else grants you permission to modify or distribute the Library or its derivative works. These actions are prohibited by law if you do not accept this License. Therefore, by modifying or distributing the Library (or any work based on the Library), you indicate your acceptance of this License to do so, and all its terms and conditions for copying, distributing or modifying the Library or works based on it.
10. Each time you redistribute the Library (or any work based on the Library), the recipient automatically receives a license from the original licensor to copy, distribute, link with or modify the Library subject to these terms and conditions. You may not impose any further restrictions on the recipients' exercise of the rights granted herein. You are not responsible for enforcing compliance by third parties to this License.
11. If, as a consequence of a court judgment or allegation of patent infringement or for any other reason (not limited to patent issues), conditions are imposed on you (whether by court order, agreement or otherwise) that contradict the conditions of this License, they do not excuse you from the conditions of this License. If you cannot distribute so as to satisfy simultaneously your obligations under this License and any other pertinent obligations, then as a consequence you may not distribute the Library at all. For example, if a patent license would not permit royalty-free redistribution of the Library by all those who receive copies directly or indirectly through you, then the only way you could satisfy both it and this License would be to refrain entirely from distribution of the Library.

If any portion of this section is held invalid or unenforceable under any particular circumstance, the balance of the section is intended to apply, and the section as a whole is intended to apply in other circumstances.

It is not the purpose of this section to induce you to infringe any patents or other property right claims or to contest validity of any such claims; this section has the sole purpose of protecting the integrity of the free software distribution system which is implemented by public license practices. Many people have made generous contributions to the wide range of software distributed through that system in reliance on consistent application of that system; it is up to the author/donor to decide if he or she is willing to distribute software through any other system and a licensee cannot impose that choice.

This section is intended to make thoroughly clear what is believed to be a consequence of the rest of this License.

12. If the distribution and/or use of the Library is restricted in certain countries either by patents or by copyrighted interfaces, the original copyright holder who places the Library under this License may add an explicit geographical distribution limitation excluding those countries, so that distribution is permitted only in or among countries not thus excluded. In such case, this License incorporates the limitation as if written in the body of this License.
13. The Free Software Foundation may publish revised and/or new versions of the Library General Public License from time to time. Such new versions will be similar in spirit to the present version, but may differ in detail to address new problems or concerns.

Each version is given a distinguishing version number. If the Library specifies a version number of this License which applies to it and "any later version", you have the option of following the terms and conditions either of that version or of any later version published by the Free Software Foundation.

If the Library does not specify a license version number, you may choose any version ever published by the Free Software Foundation.

14. If you wish to incorporate parts of the Library into other free programs whose distribution conditions are incompatible with these, write to the author to ask for permission. For software which is copyrighted by the Free Software Foundation, write to the Free Software Foundation; we sometimes make exceptions for this. Our decision will be guided by the two goals of preserving the free status of all derivatives of our free software and of promoting the sharing and reuse of software generally.

NO WARRANTY

15. BECAUSE THE LIBRARY IS LICENSED FREE OF CHARGE, THERE IS NO WARRANTY FOR THE LIBRARY, TO THE EXTENT PERMITTED BY APPLICABLE LAW. EXCEPT WHEN OTHERWISE STATED IN WRITING THE COPYRIGHT HOLDERS AND/OR OTHER PARTIES PROVIDE THE LIBRARY "AS IS" WITHOUT WARRANTY OF ANY KIND, EITHER EXPRESSED OR IMPLIED, INCLUDING, BUT NOT LIMITED TO, THE IMPLIED WARRANTIES OF MERCHANTABILITY AND FITNESS FOR A PARTICULAR PURPOSE. THE ENTIRE RISK AS TO THE QUALITY AND PERFORMANCE OF THE LIBRARY IS WITH YOU. SHOULD THE LIBRARY PROVE DEFECTIVE, YOU ASSUME THE COST OF ALL NECESSARY SERVICING, REPAIR OR CORRECTION.
16. IN NO EVENT UNLESS REQUIRED BY APPLICABLE LAW OR AGREED TO IN WRITING WILL ANY COPYRIGHT HOLDER, OR ANY OTHER PARTY WHO MAY MODIFY AND/OR REDISTRIBUTE THE LIBRARY AS PERMITTED ABOVE, BE LIABLE TO YOU FOR DAMAGES, INCLUDING ANY GENERAL, SPECIAL, INCIDENTAL OR CONSEQUENTIAL DAMAGES ARISING OUT OF THE USE OR INABILITY TO USE THE LIBRARY (INCLUDING BUT NOT LIMITED TO LOSS OF DATA OR DATA BEING RENDERED INACCURATE OR LOSSES SUSTAINED BY YOU OR THIRD PARTIES OR A FAILURE OF THE LIBRARY TO OPERATE WITH ANY OTHER SOFTWARE), EVEN IF SUCH HOLDER OR OTHER PARTY HAS BEEN ADVISED OF THE POSSIBILITY OF SUCH DAMAGES.

END OF TERMS AND CONDITIONS

How to Apply These Terms to Your New Libraries

If you develop a new library, and you want it to be of the greatest possible use to the public, we recommend making it free software that everyone can redistribute and change. You can do so by permitting redistribution under these terms (or, alternatively, under the terms of the ordinary General Public License).

To apply these terms, attach the following notices to the library. It is safest to attach them to the start of each source file to most effectively convey the exclusion of warranty; and each file should have at least the "copyright" line and a pointer to where the full notice is found.

<one line to give the library's name and a brief idea of what it does.>

Copyright (C) <year> <name of author>

This library is free software; you can redistribute it and/or modify it under the terms of the GNU Library General Public License as published by the Free Software Foundation; either version 2 of the License, or (at your option) any later version.

This library is distributed in the hope that it will be useful, but WITHOUT ANY WARRANTY; without even the implied warranty of MERCHANTABILITY or FITNESS FOR A PARTICULAR PURPOSE. See the GNU Library General Public License for more details.

You should have received a copy of the GNU Library General Public License along with this library; if not, write to the Free Software Foundation, Inc., 51 Franklin Street, Fifth Floor, Boston, MA 02110-1301 USA

Also add information on how to contact you by electronic and paper mail.

You should also get your employer (if you work as a programmer) or your school, if any, to sign a "copyright disclaimer" for the library, if necessary. Here is a sample; alter the names:

Yoyodyne, Inc., hereby disclaims all copyright interest in the library 'Frob' (a library for tweaking knobs) written by James Random Hacker.

<signature of Ty Coon>, 1 April 1990

Ty Coon, President of Vice

That's all there is to it!

GNU Lesser General Public License (LGPL) V2.1

GNU LESSER GENERAL PUBLIC LICENSE

Version 2.1, February 1999

Copyright (C) 1991, 1999 Free Software Foundation, Inc. 51 Franklin Street, Fifth Floor, Boston, MA 02110-1301 USA. Everyone is permitted to copy and distribute verbatim copies of this license document, but changing it is not allowed.

[This is the first released version of the Lesser GPL.

It also counts as the successor of the GNU Library Public License, version 2, hence the version number 2.1.]

Preamble

The licenses for most software are designed to take away your freedom to share and change it. By contrast, the GNU General Public Licenses are intended to guarantee your freedom to share and change free software--to make sure the software is free for all its users.

This license, the Lesser General Public License, applies to some specially designated software packages--typically libraries--of the Free Software Foundation and other authors who decide to use it. You can use it too, but we suggest you first think carefully about whether this license or the ordinary General Public License is the better strategy to use in any particular case, based on the explanations below.

When we speak of free software, we are referring to freedom of use, not price. Our General Public Licenses are designed to make sure that you have the freedom to distribute copies of free software (and charge for this service if you wish); that you receive source code or can get it if you want it; that you can change the software and use pieces of it in new free programs; and that you are informed that you can do these things.

To protect your rights, we need to make restrictions that forbid distributors to deny you these rights or to ask you to surrender these rights. These restrictions translate to certain responsibilities for you if you distribute copies of the library or if you modify it.

For example, if you distribute copies of the library, whether gratis or for a fee, you must give the recipients all the rights that we gave you. You must make sure that they, too, receive or can get the source code. If you link other code with the library, you must provide complete object files to the recipients, so that they can relink them with the library after making changes to the library and recompiling it. And you must show them these terms so they know their rights.

We protect your rights with a two-step method: (1) we copyright the library, and (2) we offer you this license, which gives you legal permission to copy, distribute and/or modify the library.

To protect each distributor, we want to make it very clear that there is no warranty for the free library. Also, if the library is modified by someone else and passed on, the recipients should know that what they have is not the original version, so that the original author's reputation will not be affected by problems that might be introduced by others.

Finally, software patents pose a constant threat to the existence of any free program. We wish to make sure that a company cannot effectively restrict the users of a free program by obtaining a restrictive license from a patent holder. Therefore, we insist that any patent license obtained for a version of the library must be consistent with the full freedom of use specified in this license.

Most GNU software, including some libraries, is covered by the ordinary GNU General Public License. This license, the GNU Lesser General Public License, applies to certain designated libraries, and is quite different from the ordinary General Public License. We use this license for certain libraries in order to permit linking those libraries into non-free programs.

When a program is linked with a library, whether statically or using a shared library, the combination of the two is legally speaking a combined work, a derivative of the original library. The ordinary General Public License therefore permits such linking only if the entire combination fits its criteria of freedom. The Lesser General Public License permits more lax criteria for linking other code with the library.

We call this license the "Lesser" General Public License because it does Less to protect the user's freedom than the ordinary General Public License. It also provides other free software developers Less of an advantage over competing non-free programs. These disadvantages are the reason we use the ordinary General Public License for many libraries. However, the Lesser license provides advantages in certain special circumstances.

For example, on rare occasions, there may be a special need to encourage the widest possible use of a certain library, so that it becomes a de-facto standard. To achieve this, non-free programs must be allowed to use the library. A more frequent case is that a free library does the same job as widely used non-free libraries. In this case, there is little to gain by limiting the free library to free software only, so we use the Lesser General Public License.

In other cases, permission to use a particular library in non-free programs enables a greater number of people to use a large body of free software. For example, permission to use the GNU C Library in non-free programs enables many more people to use the whole GNU operating system, as well as its variant, the GNU/Linux operating system.

Although the Lesser General Public License is Less protective of the users' freedom, it does ensure that the user of a program that is linked with the Library has the freedom and the wherewithal to run that program using a modified version of the Library.

The precise terms and conditions for copying, distribution and modification follow. Pay close attention to the difference between a "work based on the library" and a "work that uses the library". The former contains code derived from the library, whereas the latter must be combined with the library in order to run.

GNU LESSER GENERAL PUBLIC LICENSE TERMS AND CONDITIONS FOR COPYING, DISTRIBUTION AND MODIFICATION

0. This License Agreement applies to any software library or other program which contains a notice placed by the copyright holder or other authorized party saying it may be distributed under the terms of this Lesser General Public License (also called "this License"). Each licensee is addressed as "you".

A "library" means a collection of software functions and/or data prepared so as to be conveniently linked with application programs (which use some of those functions and data) to form executables.

The "Library", below, refers to any such software library or work which has been distributed under these terms. A "work based on the Library" means either the Library or any derivative work under copyright law: that is to say, a work containing the Library or a portion of it, either verbatim or with modifications and/or translated straightforwardly into another language. (Hereinafter, translation is included without limitation in the term "modification".)

"Source code" for a work means the preferred form of the work for making modifications to it. For a library, complete source code means all the source code for all modules it contains, plus any associated interface definition files, plus the scripts used to control compilation and installation of the library.

Activities other than copying, distribution and modification are not covered by this License; they are outside its scope. The act of running a program using the Library is not restricted, and output from such a program is covered only if its contents constitute a work based on the Library (independent of the use of the Library in a tool for writing it). Whether that is true depends on what the Library does and what the program that uses the Library does.

1. You may copy and distribute verbatim copies of the Library's complete source code as you receive it, in any medium, provided that you conspicuously and appropriately publish on each copy an appropriate copyright notice and disclaimer of warranty; keep intact all the notices that refer to this License and to the absence of any warranty; and distribute a copy of this License along with the Library.

You may charge a fee for the physical act of transferring a copy, and you may at your option offer warranty protection in exchange for a fee.

2. You may modify your copy or copies of the Library or any portion of it, thus forming a work based on the Library, and copy and distribute such modifications or work under the terms of Section 1 above, provided that you also meet all of these conditions:
 - a) The modified work must itself be a software library.
 - b) You must cause the files modified to carry prominent notices stating that you changed the files and the date of any change.
 - c) You must cause the whole of the work to be licensed at no charge to all third parties under the terms of this License.

- d) If a facility in the modified Library refers to a function or a table of data to be supplied by an application program that uses the facility, other than as an argument passed when the facility is invoked, then you must make a good faith effort to ensure that, in the event an application does not supply such function or table, the facility still operates, and performs whatever part of its purpose remains meaningful.

(For example, a function in a library to compute square roots has a purpose that is entirely well-defined independent of the application. Therefore, Subsection 2d requires that any application-supplied function or table used by this function must be optional: if the application does not supply it, the square root function must still compute square roots.)

These requirements apply to the modified work as a whole. If identifiable sections of that work are not derived from the Library, and can be reasonably considered independent and separate works in themselves, then this License, and its terms, do not apply to those sections when you distribute them as separate works. But when you distribute the same sections as part of a whole which is a work based on the Library, the distribution of the whole must be on the terms of this License, whose permissions for other licensees extend to the entire whole, and thus to each and every part regardless of who wrote it.

Thus, it is not the intent of this section to claim rights or contest your rights to work written entirely by you; rather, the intent is to exercise the right to control the distribution of derivative or collective works based on the Library.

In addition, mere aggregation of another work not based on the Library with the Library (or with a work based on the Library) on a volume of a storage or distribution medium does not bring the other work under the scope of this License.

3. You may opt to apply the terms of the ordinary GNU General Public License instead of this License to a given copy of the Library. To do this, you must alter all the notices that refer to this License, so that they refer to the ordinary GNU General Public License, version 2, instead of to this License. (If a newer version than version 2 of the ordinary GNU General Public License has appeared, then you can specify that version instead if you wish.) Do not make any other change in these notices.

Once this change is made in a given copy, it is irreversible for that copy, so the ordinary GNU General Public License applies to all subsequent copies and derivative works made from that copy.

This option is useful when you wish to copy part of the code of the Library into a program that is not a library.

4. You may copy and distribute the Library (or a portion or derivative of it, under Section 2) in object code or executable form under the terms of Sections 1 and 2 above provided that you accompany it with the complete corresponding machine-readable source code, which must be distributed under the terms of Sections 1 and 2 above on a medium customarily used for software interchange.

If distribution of object code is made by offering access to copy from a designated place, then offering equivalent access to copy the source code from the same place satisfies the requirement to distribute the source code, even though third parties are not compelled to copy the source along with the object code.

5. A program that contains no derivative of any portion of the Library, but is designed to work with the Library by being compiled or linked with it, is called a "work that uses the Library". Such a work, in isolation, is not a derivative work of the Library, and therefore falls outside the scope of this License.

However, linking a "work that uses the Library" with the Library creates an executable that is a derivative of the Library (because it contains portions of the Library), rather than a "work that uses the library". The executable is therefore covered by this License. Section 6 states terms for distribution of such executables.

When a "work that uses the Library" uses material from a header file that is part of the Library, the object code for the work may be a derivative work of the Library even though the source code is not. Whether this is true is especially significant if the work can be linked without the Library, or if the work is itself a library. The threshold for this to be true is not precisely defined by law.

If such an object file uses only numerical parameters, data structure layouts and accessors, and small macros and small inline functions (ten lines or less in length), then the use of the object file is unrestricted, regardless of whether it is legally a derivative work. (Executables containing this object code plus portions of the Library will still fall under Section 6.)

Otherwise, if the work is a derivative of the Library, you may distribute the object code for the work under the terms of Section 6. Any executables containing that work also fall under Section 6, whether or not they are linked directly with the Library itself.

6. As an exception to the Sections above, you may also combine or link a "work that uses the Library" with the Library to produce a work containing portions of the Library, and distribute that work under terms of your choice, provided that the terms permit modification of the work for the customer's own use and reverse engineering for debugging such modifications.

You must give prominent notice with each copy of the work that the Library is used in it and that the Library and its use are covered by this License. You must supply a copy of this License. If the work during execution displays copyright notices, you must include the copyright notice for the Library among them, as well as a reference directing the user to the copy of this License. Also, you must do one of these things:

- a) Accompany the work with the complete corresponding machine-readable source code for the Library including whatever changes were used in the work (which must be distributed under Sections 1 and 2 above); and, if the work is an executable linked with the Library, with the complete machine-readable "work that uses the Library", as object code and/or source code, so that the user can modify the Library and then relink to produce a modified executable containing the modified Library. (It is understood that the user who changes the contents of definitions files in the Library will not necessarily be able to recompile the application to use the modified definitions.)

- b) Use a suitable shared library mechanism for linking with the Library. A suitable mechanism is one that (1) uses at run time a copy of the library already present on the user's computer system, rather than copying library functions into the executable, and (2) will operate properly with a modified version of the library, if the user installs one, as long as the modified version is interface-compatible with the version that the work was made with.
- c) Accompany the work with a written offer, valid for at least three years, to give the same user the materials specified in Subsection 6a, above, for a charge no more than the cost of performing this distribution.
- d) If distribution of the work is made by offering access to copy from a designated place, offer equivalent access to copy the above specified materials from the same place.
- e) Verify that the user has already received a copy of these materials or that you have already sent this user a copy.

For an executable, the required form of the "work that uses the Library" must include any data and utility programs needed for reproducing the executable from it. However, as a special exception, the materials to be distributed need not include anything that is normally distributed (in either source or binary form) with the major components (compiler, kernel, and so on) of the operating system on which the executable runs, unless that component itself accompanies the executable.

It may happen that this requirement contradicts the license restrictions of other proprietary libraries that do not normally accompany the operating system. Such a contradiction means you cannot use both them and the Library together in an executable that you distribute.

- 7. You may place library facilities that are a work based on the Library side-by-side in a single library together with other library facilities not covered by this License, and distribute such a combined library, provided that the separate distribution of the work based on the Library and of the other library facilities is otherwise permitted, and provided that you do these two things:
 - a) Accompany the combined library with a copy of the same work based on the Library, uncombined with any other library facilities. This must be distributed under the terms of the Sections above.
 - b) Give prominent notice with the combined library of the fact that part of it is a work based on the Library, and explaining where to find the accompanying uncombined form of the same work.
- 8. You may not copy, modify, sublicense, link with, or distribute the Library except as expressly provided under this License. Any attempt otherwise to copy, modify, sublicense, link with, or distribute the Library is void, and will automatically terminate your rights under this License. However, parties who have received copies, or rights, from you under this License will not have their licenses terminated so long as such parties remain in full compliance.
- 9. You are not required to accept this License, since you have not signed it. However, nothing else grants you permission to modify or distribute the Library or its derivative works. These actions are prohibited by law if you do not accept this License. Therefore, by modifying or distributing the Library (or any work based on the Library), you indicate your acceptance of this License to do so, and all its terms and conditions for copying, distributing or modifying the Library or works based on it.
- 10. Each time you redistribute the Library (or any work based on the Library), the recipient automatically receives a license from the original licensor to copy, distribute, link with or modify the Library subject to these terms and conditions. You may not impose any further restrictions on the recipients' exercise of the rights granted herein. You are not responsible for enforcing compliance by third parties with this License.
- 11. If, as a consequence of a court judgment or allegation of patent infringement or for any other reason (not limited to patent issues), conditions are imposed on you (whether by court order, agreement or otherwise) that contradict the conditions of this License, they do not excuse you from the conditions of this License. If you cannot distribute so as to satisfy simultaneously your obligations under this License and any other pertinent obligations, then as a consequence you may not distribute the Library at all. For example, if a patent license would not permit royalty-free redistribution of the Library by all those who receive copies directly or indirectly through you, then the only way you could satisfy both it and this License would be to refrain entirely from distribution of the Library.

If any portion of this section is held invalid or unenforceable under any particular circumstance, the balance of the section is intended to apply, and the section as a whole is intended to apply in other circumstances.

It is not the purpose of this section to induce you to infringe any patents or other property right claims or to contest validity of any such claims; this section has the sole purpose of protecting the integrity of the free software distribution system which is implemented by public license practices. Many people have made generous contributions to the wide range of software distributed through that system in reliance on consistent application of that system; it is up to the author/donor to decide if he or she is willing to distribute software through any other system and a licensee cannot impose that choice.

This section is intended to make thoroughly clear what is believed to be a consequence of the rest of this License.

- 12. If the distribution and/or use of the Library is restricted in certain countries either by patents or by copyrighted interfaces, the original copyright holder who places the Library under this License may add an explicit geographical distribution limitation excluding those countries, so that distribution is permitted only in or among countries not thus excluded. In such case, this License incorporates the limitation as if written in the body of this License.

13. The Free Software Foundation may publish revised and/or new versions of the Lesser General Public License from time to time. Such new versions will be similar in spirit to the present version, but may differ in detail to address new problems or concerns.

Each version is given a distinguishing version number. If the Library specifies a version number of this License which applies to it and "any later version", you have the option of following the terms and conditions either of that version or of any later version published by the Free Software Foundation. If the Library does not specify a license version number, you may choose any version ever published by the Free Software Foundation.

14. If you wish to incorporate parts of the Library into other free programs whose distribution conditions are incompatible with these, write to the author to ask for permission. For software which is copyrighted by the Free Software Foundation, write to the Free Software Foundation; we sometimes make exceptions for this. Our decision will be guided by the two goals of preserving the free status of all derivatives of our free software and of promoting the sharing and reuse of software generally.

NO WARRANTY

15. BECAUSE THE LIBRARY IS LICENSED FREE OF CHARGE, THERE IS NO WARRANTY FOR THE LIBRARY, TO THE EXTENT PERMITTED BY APPLICABLE LAW. EXCEPT WHEN OTHERWISE STATED IN WRITING THE COPYRIGHT HOLDERS AND/OR OTHER PARTIES PROVIDE THE LIBRARY "AS IS" WITHOUT WARRANTY OF ANY KIND, EITHER EXPRESSED OR IMPLIED, INCLUDING, BUT NOT LIMITED TO, THE IMPLIED WARRANTIES OF MERCHANTABILITY AND FITNESS FOR A PARTICULAR PURPOSE. THE ENTIRE RISK AS TO THE QUALITY AND PERFORMANCE OF THE LIBRARY IS WITH YOU. SHOULD THE LIBRARY PROVE DEFECTIVE, YOU ASSUME THE COST OF ALL NECESSARY SERVICING, REPAIR OR CORRECTION.

16. IN NO EVENT UNLESS REQUIRED BY APPLICABLE LAW OR AGREED TO IN WRITING WILL ANY COPYRIGHT HOLDER, OR ANY OTHER PARTY WHO MAY MODIFY AND/OR REDISTRIBUTE THE LIBRARY AS PERMITTED ABOVE, BE LIABLE TO YOU FOR DAMAGES, INCLUDING ANY GENERAL, SPECIAL, INCIDENTAL OR CONSEQUENTIAL DAMAGES ARISING OUT OF THE USE OR INABILITY TO USE THE LIBRARY (INCLUDING BUT NOT LIMITED TO LOSS OF DATA OR DATA BEING RENDERED INACCURATE OR LOSSES SUSTAINED BY YOU OR THIRD PARTIES OR A FAILURE OF THE LIBRARY TO OPERATE WITH ANY OTHER SOFTWARE), EVEN IF SUCH HOLDER OR OTHER PARTY HAS BEEN ADVISED OF THE POSSIBILITY OF SUCH DAMAGES.

END OF TERMS AND CONDITIONS

How to Apply These Terms to Your New Libraries

If you develop a new library, and you want it to be of the greatest possible use to the public, we recommend making it free software that everyone can redistribute and change. You can do so by permitting redistribution under these terms (or, alternatively, under the terms of the ordinary General Public License).

To apply these terms, attach the following notices to the library. It is safest to attach them to the start of each source file to most effectively convey the exclusion of warranty; and each file should have at least the "copyright" line and a pointer to where the full notice is found.

<one line to give the library's name and a brief idea of what it does.>
Copyright (C) <year> <name of author>

This library is free software; you can redistribute it and/or modify it under the terms of the GNU Lesser General Public License as published by the Free Software Foundation; either version 2.1 of the License, or (at your option) any later version.

This library is distributed in the hope that it will be useful, but WITHOUT ANY WARRANTY; without even the implied warranty of MERCHANTABILITY or FITNESS FOR A PARTICULAR PURPOSE. See the GNU Lesser General Public License for more details.

You should have received a copy of the GNU Lesser General Public License along with this library; if not, write to the Free Software Foundation, Inc., 51 Franklin Street, Fifth Floor, Boston, MA 02110-1301 USA

Also add information on how to contact you by electronic and paper mail.

You should also get your employer (if you work as a programmer) or your school, if any, to sign a "copyright disclaimer" for the library, if necessary. Here is a sample; alter the names:

Yoyodyne, Inc., hereby disclaims all copyright interest in the library 'Frob' (a library for tweaking knobs) written by James Random Hacker.

<signature of Ty Coon>, 1 April 1990
Ty Coon, President of Vice

That's all there is to it!

Libpng License

This copy of the libpng notices is provided for your convenience. In case of any discrepancy between this copy and the notices in the file png.h that is included in the libpng distribution, the latter shall prevail.

COPYRIGHT NOTICE, DISCLAIMER, and LICENSE:

If you modify libpng you may insert additional notices immediately following this sentence.

This code is released under the libpng license.

libpng versions 1.2.6, August 15, 2004, through 1.2.52, November 20, 2014, are Copyright (c) 2004, 2006-2014 Glenn Randers-Pehrson, and are distributed according to the same disclaimer and license as libpng-1.2.5 with the following individual added to the list of Contributing Authors

Cosmin Truta

libpng versions 1.0.7, July 1, 2000, through 1.2.5 - October 3, 2002, are Copyright (c) 2000-2002 Glenn Randers-Pehrson, and are distributed according to the same disclaimer and license as libpng-1.0.6 with the following individuals added to the list of Contributing Authors

Simon-Pierre Cadieux
Eric S. Raymond
Gilles Vollant

and with the following additions to the disclaimer:

There is no warranty against interference with your enjoyment of the library or against infringement. There is no warranty that our efforts or the library will fulfill any of your particular purposes or needs. This library is provided with all faults, and the entire risk of satisfactory quality, performance, accuracy, and effort is with the user.

libpng versions 0.97, January 1998, through 1.0.6, March 20, 2000, are Copyright (c) 1998, 1999 Glenn Randers-Pehrson, and are distributed according to the same disclaimer and license as libpng-0.96, with the following individuals added to the list of Contributing Authors:

Tom Lane
Glenn Randers-Pehrson
Willem van Schaik

libpng versions 0.89, June 1996, through 0.96, May 1997, are Copyright (c) 1996, 1997 Andreas Dilger

Distributed according to the same disclaimer and license as libpng-0.88, with the following individuals added to the list of Contributing Authors:

John Bowler
Kevin Bracey
Sam Bushell
Magnus Holmgren
Greg Roelofs
Tom Tanner

libpng versions 0.5, May 1995, through 0.88, January 1996, are Copyright (c) 1995, 1996 Guy Eric Schalnat, Group 42, Inc.

For the purposes of this copyright and license, "Contributing Authors" is defined as the following set of individuals:

Andreas Dilger
Dave Martindale
Guy Eric Schalnat
Paul Schmidt
Tim Wegner

The PNG Reference Library is supplied "AS IS". The Contributing Authors and Group 42, Inc. disclaim all warranties, expressed or implied, including, without limitation, the warranties of merchantability and of fitness for any purpose. The Contributing Authors and Group 42, Inc. assume no liability for direct, indirect, incidental, special, exemplary, or consequential damages, which may result from the use of the PNG Reference Library, even if advised of the possibility of such damage.

Permission is hereby granted to use, copy, modify, and distribute this source code, or portions hereof, for any purpose, without fee, subject to the following restrictions:

1. The origin of this source code must not be misrepresented.
2. Altered versions must be plainly marked as such and must not be misrepresented as being the original source.
3. This Copyright notice may not be removed or altered from any source or altered source distribution.

The Contributing Authors and Group 42, Inc. specifically permit, without fee, and encourage the use of this source code as a component to supporting the PNG file format in commercial products. If you use this source code in a product, acknowledgment is not required but would be appreciated.

A "png_get_copyright" function is available, for convenient use in "about" boxes and the like:

```
printf("%s",png_get_copyright(NULL));
```

Also, the PNG logo (in PNG format, of course) is supplied in the files "pngbar.png" and "pngbar.jpg (88x31) and "pngnow.png" (98x31).

Libpng is OSI Certified Open Source Software. OSI Certified Open Source is a certification mark of the Open Source Initiative.

Glenn Randers-Pehrson
glennrp at users.sourceforge.net
November 20, 2014

MIT License

The MIT License
=====

Copyright (c) <year> <copyright holders>

Permission is hereby granted, free of charge, to any person obtaining a copy of this software and associated documentation files (the "Software"), to deal in the Software without restriction, including without limitation the rights to use, copy, modify, merge, publish, distribute, sublicense, and/or sell copies of the Software, and to permit persons to whom the Software is furnished to do so, subject to the following conditions:

The above copyright notice and this permission notice shall be included in all copies or substantial portions of the Software.

THE SOFTWARE IS PROVIDED "AS IS", WITHOUT WARRANTY OF ANY KIND, EXPRESS OR IMPLIED, INCLUDING BUT NOT LIMITED TO THE WARRANTIES OF MERCHANTABILITY, FITNESS FOR A PARTICULAR PURPOSE AND NONINFRINGEMENT. IN NO EVENT SHALL THE AUTHORS OR COPYRIGHT HOLDERS BE LIABLE FOR ANY CLAIM, DAMAGES OR OTHER LIABILITY, WHETHER IN AN ACTION OF CONTRACT, TORT OR OTHERWISE, ARISING FROM, OUT OF OR IN CONNECTION WITH THE SOFTWARE OR THE USE OR OTHER DEALINGS IN THE SOFTWARE.

Mozilla Public License(MPL) V2.0

Mozilla Public License Version 2.0
=====

1. Definitions

- 1.1. "Contributor"
means each individual or legal entity that creates, contributes to the creation of, or owns Covered Software.
- 1.2. "Contributor Version"
means the combination of the Contributions of others (if any) used by a Contributor and that particular Contributor's Contribution.
- 1.3. "Contribution"
means Covered Software of a particular Contributor.
- 1.4. "Covered Software"
means Source Code Form to which the initial Contributor has attached the notice in Exhibit A, the Executable Form of such Source Code Form, and Modifications of such Source Code Form, in each case including portions thereof.
- 1.5. "Incompatible With Secondary Licenses"
means
 - (a) that the initial Contributor has attached the notice described in Exhibit B to the Covered Software; or
 - (b) that the Covered Software was made available under the terms of version 1.1 or earlier of the License, but not also under the terms of a Secondary License.
- 1.6. "Executable Form"
means any form of the work other than Source Code Form.
- 1.7. "Larger Work"
means a work that combines Covered Software with other material, in a separate file or files, that is not Covered Software.
- 1.8. "License"
means this document.
- 1.9. "Licensable"
means having the right to grant, to the maximum extent possible, whether at the time of the initial grant or subsequently, any and all of the rights conveyed by this License.

- 1.10. "Modifications"
means any of the following:
- (a) any file in Source Code Form that results from an addition to, deletion from, or modification of the contents of Covered Software; or
 - (b) any new file in Source Code Form that contains any Covered Software.
- 1.11. "Patent Claims" of a Contributor
means any patent claim(s), including without limitation, method, process, and apparatus claims, in any patent licensable by such Contributor that would be infringed, but for the grant of the License, by the making, using, selling, offering for sale, having made, import, or transfer of either its Contributions or its Contributor Version.
- 1.12. "Secondary License"
means either the GNU General Public License, Version 2.0, the GNU Lesser General Public License, Version 2.1, the GNU Affero General Public License, Version 3.0, or any later versions of those licenses.
- 1.13. "Source Code Form"
means the form of the work preferred for making modifications.
- 1.14. "You" (or "Your")
means an individual or a legal entity exercising rights under this License. For legal entities, "You" includes any entity that controls, is controlled by, or is under common control with You. For purposes of this definition, "control" means (a) the power, direct or indirect, to cause the direction or management of such entity, whether by contract or otherwise, or (b) ownership of more than fifty percent (50%) of the outstanding shares or beneficial ownership of such entity.

2. License Grants and Conditions

2.1. Grants

Each Contributor hereby grants You a world-wide, royalty-free, non-exclusive license:

- (a) under intellectual property rights (other than patent or trademark) licensable by such Contributor to use, reproduce, make available, modify, display, perform, distribute, and otherwise exploit its Contributions, either on an unmodified basis, with Modifications, or as part of a Larger Work; and
- (b) under Patent Claims of such Contributor to make, use, sell, offer for sale, have made, import, and otherwise transfer either its Contributions or its Contributor Version.

2.2. Effective Date

The licenses granted in Section 2.1 with respect to any Contribution become effective for each Contribution on the date the Contributor first distributes such Contribution.

2.3. Limitations on Grant Scope

The licenses granted in this Section 2 are the only rights granted under this License. No additional rights or licenses will be implied from the distribution or licensing of Covered Software under this License. Notwithstanding Section 2.1 (b) above, no patent license is granted by a Contributor:

- (a) for any code that a Contributor has removed from Covered Software; or
- (b) for infringements caused by: (i) Your and any other third party's modifications of Covered Software, or (ii) the combination of its Contributions with other software (except as part of its Contributor Version); or
- (c) under Patent Claims infringed by Covered Software in the absence of its Contributions.

This License does not grant any rights in the trademarks, service marks, or logos of any Contributor (except as may be necessary to comply with the notice requirements in Section 3.4).

2.4. Subsequent Licenses

No Contributor makes additional grants as a result of Your choice to distribute the Covered Software under a subsequent version of this License (see Section 10.2) or under the terms of a Secondary License (if permitted under the terms of Section 3.3).

2.5. Representation

Each Contributor represents that the Contributor believes its Contributions are its original creation(s) or it has sufficient rights to grant the rights to its Contributions conveyed by this License.

2.6. Fair Use

This License is not intended to limit any rights You have under applicable copyright doctrines of fair use, fair dealing, or other equivalents.

2.7. Conditions

Sections 3.1, 3.2, 3.3, and 3.4 are conditions of the licenses granted in Section 2.1.

3. Responsibilities

3.1. Distribution of Source Form

All distribution of Covered Software in Source Code Form, including any Modifications that You create or to which You contribute, must be under the terms of this License. You must inform recipients that the Source Code Form of the Covered Software is governed by the terms of this License, and how they can obtain a copy of this License. You may not attempt to alter or restrict the recipients' rights in the Source Code Form.

3.2. Distribution of Executable Form

If You distribute Covered Software in Executable Form then:

- (a) such Covered Software must also be made available in Source Code Form, as described in Section 3.1, and You must inform recipients of the Executable Form how they can obtain a copy of such Source Code Form by reasonable means in a timely manner, at a charge no more than the cost of distribution to the recipient; and
- (b) You may distribute such Executable Form under the terms of this License, or sublicense it under different terms, provided that the license for the Executable Form does not attempt to limit or alter the recipients' rights in the Source Code Form under this License.

3.3. Distribution of a Larger Work

You may create and distribute a Larger Work under terms of Your choice, provided that You also comply with the requirements of this License for the Covered Software. If the Larger Work is a combination of Covered Software with a work governed by one or more Secondary Licenses, and the Covered Software is not Incompatible With Secondary Licenses, this License permits You to additionally distribute such Covered Software under the terms of such Secondary License(s), so that the recipient of the Larger Work may, at their option, further distribute the Covered Software under the terms of either this License or such Secondary License(s).

3.4. Notices

You may not remove or alter the substance of any license notices (including copyright notices, patent notices, disclaimers of warranty, or limitations of liability) contained within the Source Code Form of the Covered Software, except that You may alter any license notices to the extent required to remedy known factual inaccuracies.

3.5. Application of Additional Terms

You may choose to offer, and to charge a fee for, warranty, support, indemnity or liability obligations to one or more recipients of Covered Software. However, You may do so only on Your own behalf, and not on behalf of any Contributor. You must make it absolutely clear that any such warranty, support, indemnity, or liability obligation is offered by You alone, and You hereby agree to indemnify every Contributor for any liability incurred by such Contributor as a result of warranty, support, indemnity or liability terms You offer. You may include additional disclaimers of warranty and limitations of liability specific to any jurisdiction.

4. Inability to Comply Due to Statute or Regulation

If it is impossible for You to comply with any of the terms of this License with respect to some or all of the Covered Software due to statute, judicial order, or regulation then You must: (a) comply with the terms of this License to the maximum extent possible; and (b) describe the limitations and the code they affect. Such description must be placed in a text file included with all distributions of the Covered Software under this License. Except to the extent prohibited by statute or regulation, such description must be sufficiently detailed for a recipient of ordinary skill to be able to understand it.

5. Termination

- 5.1. The rights granted under this License will terminate automatically if You fail to comply with any of its terms. However, if You become compliant, then the rights granted under this License from a particular Contributor are reinstated (a) provisionally, unless and until such Contributor explicitly and finally terminates Your grants, and (b) on an ongoing basis, if such Contributor fails to notify You of the non-compliance by some reasonable means prior to 60 days after You have come back into compliance. Moreover, Your grants from a particular Contributor are reinstated on an ongoing basis if such Contributor notifies You of the non-compliance by some reasonable means, this is the first time You have received notice of non-compliance with this License from such Contributor, and You become compliant prior to 30 days after Your receipt of the notice.
- 5.2. If You initiate litigation against any entity by asserting a patent infringement claim (excluding declaratory judgment actions, counter-claims, and cross-claims) alleging that a Contributor Version directly or indirectly infringes any patent, then the rights granted to You by any and all Contributors for the Covered Software under Section 2.1 of this License shall terminate.
- 5.3. In the event of termination under Sections 5.1 or 5.2 above, all end user license agreements (excluding distributors and resellers) which have been validly granted by You or Your distributors under this License prior to termination shall survive termination.

6. Disclaimer of Warranty

Covered Software is provided under this License on an "as is" basis, without warranty of any kind, either expressed, implied, or statutory, including, without limitation, warranties that the Covered Software is free of defects, merchantable, fit for a particular purpose or non-infringing. The entire risk as to the quality and performance of the Covered Software is with You. Should any Covered Software prove defective in any respect, You (not any Contributor) assume the cost of any necessary servicing, repair, or correction. This disclaimer of warranty constitutes an essential part of this License. No use of any Covered Software is authorized under this License except under this disclaimer.

7. Limitation of Liability

Under no circumstances and under no legal theory, whether tort (including negligence), contract, or otherwise, shall any Contributor, or anyone who distributes Covered Software as permitted above, be liable to You for any direct, indirect, special, incidental, or consequential damages of any character including, without limitation, damages for lost profits, loss of goodwill, work stoppage, computer failure or malfunction, or any and all other commercial damages or losses, even if such party shall have been informed of the possibility of such damages. This limitation of liability shall not apply to liability for death or personal injury resulting from such party's negligence to the extent applicable law prohibits such limitation. Some jurisdictions do not allow the exclusion or limitation of incidental or consequential damages, so this exclusion and limitation may not apply to You.

8. Litigation

Any litigation relating to this License may be brought only in the courts of a jurisdiction where the defendant maintains its principal place of business and such litigation shall be governed by laws of that jurisdiction, without reference to its conflict-of-law provisions. Nothing in this Section shall prevent a party's ability to bring cross-claims or counter-claims.

9. Miscellaneous

This License represents the complete agreement concerning the subject matter hereof. If any provision of this License is held to be unenforceable, such provision shall be reformed only to the extent necessary to make it enforceable. Any law or regulation which provides that the language of a contract shall be construed against the drafter shall not be used to construe this License against a Contributor.

10. Versions of the License

10.1. New Versions

Mozilla Foundation is the license steward. Except as provided in Section 10.3, no one other than the license steward has the right to modify or publish new versions of this License. Each version will be given a distinguishing version number.

10.2. Effect of New Versions

You may distribute the Covered Software under the terms of the version of the License under which You originally received the Covered Software, or under the terms of any subsequent version published by the license steward.

10.3. Modified Versions

If you create software not governed by this License, and you want to create a new license for such software, you may create and use a modified version of this License if you rename the license and remove any references to the name of the license steward (except to note that such modified license differs from this License).

10.4. Distributing Source Code Form that is Incompatible With Secondary Licenses

If You choose to distribute Source Code Form that is Incompatible With Secondary Licenses under the terms of this version of the License, the notice described in Exhibit B of this License must be attached.

Exhibit A - Source Code Form License Notice

This Source Code Form is subject to the terms of the Mozilla Public License, v. 2.0. If a copy of the MPL was not distributed with this file, You can obtain one at <https://mozilla.org/MPL/2.0/>.

If it is not possible or desirable to put the notice in a particular file, then You may include the notice in a location (such as a LICENSE file in a relevant directory) where a recipient would be likely to look for such a notice.

You may add additional accurate notices of copyright ownership.

Exhibit B - "Incompatible With Secondary Licenses" Notice

This Source Code Form is "Incompatible With Secondary Licenses", as defined by the Mozilla Public License, v. 2.0.

OpenSSL License

LICENSE ISSUES

=====

The OpenSSL toolkit stays under a dual license, i.e. both the conditions of the OpenSSL License and the original SSLeay license apply to the toolkit. See below for the actual license texts. Actually both licenses are BSD-style Open Source licenses. In case of any license issues related to OpenSSL please contact openssl-core@openssl.org.

OpenSSL License

=====

Copyright (c) 1998-2011 The OpenSSL Project. All rights reserved.

Redistribution and use in source and binary forms, with or without modification, are permitted provided that the following conditions are met:

1. Redistributions of source code must retain the above copyright notice, this list of conditions and the following disclaimer.
2. Redistributions in binary form must reproduce the above copyright notice, this list of conditions and the following disclaimer in the documentation and/or other materials provided with the distribution.
3. All advertising materials mentioning features or use of this software must display the following acknowledgment: "This product includes software developed by the OpenSSL Project for use in the OpenSSL Toolkit. (<http://www.openssl.org/>)"
4. The names "OpenSSL Toolkit" and "OpenSSL Project" must not be used to endorse or promote products derived from this software without prior written permission. For written permission, please contact openssl-core@openssl.org.
5. Products derived from this software may not be called "OpenSSL" nor may "OpenSSL" appear in their names without prior written permission of the OpenSSL Project.
6. Redistributions of any form whatsoever must retain the following acknowledgment: "This product includes software developed by the OpenSSL Project for use in the OpenSSL Toolkit (<http://www.openssl.org/>)"

THIS SOFTWARE IS PROVIDED BY THE OpenSSL PROJECT "AS IS" AND ANY EXPRESSED OR IMPLIED WARRANTIES, INCLUDING, BUT NOT LIMITED TO, THE IMPLIED WARRANTIES OF MERCHANTABILITY AND FITNESS FOR A PARTICULAR PURPOSE ARE DISCLAIMED.

IN NO EVENT SHALL THE OpenSSL PROJECT OR ITS CONTRIBUTORS BE LIABLE FOR ANY DIRECT, INDIRECT, INCIDENTAL, SPECIAL, EXEMPLARY, OR CONSEQUENTIAL DAMAGES (INCLUDING, BUT NOT LIMITED TO, PROCUREMENT OF SUBSTITUTE GOODS OR SERVICES; LOSS OF USE, DATA, OR PROFITS; OR BUSINESS INTERRUPTION)

HOWEVER CAUSED AND ON ANY THEORY OF LIABILITY, WHETHER IN CONTRACT, STRICT LIABILITY, OR TORT (INCLUDING NEGLIGENCE OR OTHERWISE) ARISING IN ANY WAY OUT OF THE USE OF THIS SOFTWARE, EVEN IF ADVISED OF THE POSSIBILITY OF SUCH DAMAGE.

=====

This product includes cryptographic software written by Eric Young (ey@cryptsoft.com). This product includes software written by Tim Hudson (tjh@cryptsoft.com).

Original SSLeay License

Copyright (C) 1995-1998 Eric Young (ey@cryptsoft.com)
All rights reserved.

This package is an SSL implementation written by Eric Young (ey@cryptsoft.com). The implementation was written so as to conform with Netscapes SSL.

This library is free for commercial and non-commercial use as long as the following conditions are adhered to. The following conditions apply to all code found in this distribution, be it the RC4, RSA, lhash, DES, etc., code; not just the SSL code. The SSL documentation included with this distribution is covered by the same copyright terms except that the holder is Tim Hudson (tjh@cryptsoft.com).

Copyright remains Eric Young's, and as such any Copyright notices in the code are not to be removed. If this package is used in a product, Eric Young should be given attribution as the author of the parts of the library used. This can be in the form of a textual message at program startup or in documentation (online or textual) provided with the package.

Redistribution and use in source and binary forms, with or without modification, are permitted provided that the following conditions are met:

1. Redistributions of source code must retain the copyright notice, this list of conditions and the following disclaimer.
2. Redistributions in binary form must reproduce the above copyright notice, this list of conditions and the following disclaimer in the documentation and/or other materials provided with the distribution.

3. All advertising materials mentioning features or use of this software must display the following acknowledgement: "This product includes cryptographic software written by Eric Young (eay@cryptsoft.com)" The word 'cryptographic' can be left out if the routines from the library being used are not cryptographic related :-).
4. If you include any Windows specific code (or a derivative thereof) from the apps directory (application code) you must include an acknowledgement: "This product includes software written by Tim Hudson (tjh@cryptsoft.com)"

THIS SOFTWARE IS PROVIDED BY ERIC YOUNG "AS IS" AND ANY EXPRESS OR IMPLIED WARRANTIES, INCLUDING, BUT NOT LIMITED TO, THE IMPLIED WARRANTIES OF MERCHANTABILITY AND FITNESS FOR A PARTICULAR PURPOSE ARE DISCLAIMED. IN NO EVENT SHALL THE AUTHOR OR CONTRIBUTORS BE LIABLE FOR ANY DIRECT, INDIRECT, INCIDENTAL, SPECIAL, EXEMPLARY, OR CONSEQUENTIAL DAMAGES (INCLUDING, BUT NOT LIMITED TO, PROCUREMENT OF SUBSTITUTE GOODS OR SERVICES; LOSS OF USE, DATA, OR PROFITS; OR BUSINESS INTERRUPTION) HOWEVER CAUSED AND ON ANY THEORY OF LIABILITY, WHETHER IN CONTRACT, STRICT LIABILITY, OR TORT (INCLUDING NEGLIGENCE OR OTHERWISE) ARISING IN ANY WAY OUT OF THE USE OF THIS SOFTWARE, EVEN IF ADVISED OF THE POSSIBILITY OF SUCH DAMAGE.

The licence and distribution terms for any publically available version or derivative of this code cannot be changed. i.e. this code cannot simply be copied and put under another distribution licence [including the GNU Public Licence.]

TI-TSPA License

Texas Instruments Incorporated
Technology and Software Publicly Available
Software License Agreement

Important - Please read the following license agreement carefully. This is a legally binding agreement. Do not click "I have read and agree" or use (as applicable) the Licensed Materials unless: (1) you are authorized to accept and agree to the terms of this license agreement on behalf of yourself or your company (as applicable) and (2) you intend to be bound by the terms of this license agreement on behalf of yourself or your company (as applicable).

This Software License Agreement ("Agreement") is a legal agreement between you (either an individual or entity) and Texas Instruments Incorporated ("TI"), 12500 TI Boulevard, Dallas, Texas 75243. The "Licensed Materials" subject to this Agreement include the software programs (in whole or in part), that accompany this Agreement and set forth in the applicable software manifest and which you access "on-line" and/or electronic documentation (in whole or in part) associated and provided with these software programs. By installing, copying or otherwise using the Licensed Materials you agree to abide by the terms of this Agreement. If you choose not to accept or agree with these terms, do not download or install the Licensed Materials.

Note Regarding Possible Access to Open Source Software: The Licensed Materials may be bundled with Open Source Software. "Open Source Software" means any software licensed under terms requiring that (A) other software ("Proprietary Software") incorporated, combined or distributed with such software or developed using such software: (i) be disclosed or distributed in source code form; or (ii) otherwise be licensed on terms inconsistent with the terms of this Agreement, including but not limited to permitting use of the Proprietary Software on or with devices other than TI Devices, or (B) require the owner of Proprietary Software to license any of its patents to users of the Open Source Software and/or Proprietary Software incorporated, combined or distributed with such Open Source Software or developed using such Open Source Software.

You may gain access to Open Source Software, in which case such Open Source Software will be listed in the applicable software manifest (in whole or in part, the "Open Source Materials"). Your use of the Open Source Materials is subject to the separate licensing terms applicable to such Open Source Materials as specified in the applicable software manifest. For clarification, this Agreement does not limit your rights under, or grant you rights that supersede, the license terms of any applicable Open Source Materials license agreement. If any of the Open Source Materials have been provided to you in object code only, TI will provide to you or show you where can access the source code versions of such Open Source Materials if you contact TI at Texas Instruments Incorporated, 12500 TI Boulevard, Mail Station 8638, Dallas, Texas 75243, Attention: Contracts Manager. You may terminate this Agreement in the event you choose not to accept or agree with the terms in any applicable Open Source Materials license agreement, provided that such termination occurs within five (5) calendar days of acceptance of this Agreement and you abide by all applicable license terms in this Agreement until such termination.

1. License.
 - a. Source Code License. For the Licensed Materials provided in source code format, TI hereby grants to you a limited, non-exclusive license to reproduce, use, and create modified or derivative works of the Licensed Materials provided to you in source code format and to distribute an unlimited number of copies of such source code Licensed Materials, or any derivatives thereof, in any format.
 - b. Object Code License. For the Licensed Materials provided in object code format, TI hereby grants to you a limited, non-exclusive license to reproduce and use the Licensed Materials provided to you in object code format and to distribute an unlimited number of object or executable copies of such object code Licensed Materials.
2. Termination. This Agreement is effective until terminated. Without prejudice to any other rights, TI may terminate your right to use the Licensed Materials under this Agreement if you fail to comply with the terms of this Agreement. In such event, you shall destroy all copies of the Licensed Materials, including all portions and derivatives thereof.

3. Intellectual Property Rights.

- a. The Licensed Materials being provided to you hereunder are being made publicly available by TI, even though they contain copyrighted material of TI and its licensors, if applicable. In no event may you alter, remove or destroy any copyright notice included in the Licensed Materials. To the extent that any of the Licensed Materials are provided in binary or object code only, you may not unlock, decompile, reverse engineer, disassemble or otherwise translate such binary or object code to human-perceivable form. The source code of such reverse engineered code may contain TI trade secret and other proprietary information. TI reserves all rights not specifically granted under this Agreement.
- b. Certain Licensed Materials may (i) require patent licenses from third parties claiming patent rights covering implementation of the Licensed Materials or (ii) be based on industry recognized standards or software programs published by industry recognized standards bodies and certain third parties may claim to own patents or copyrights that cover implementation of those standards. You acknowledge and agree that this Agreement does not convey a license to any such third party patents and copyrights.
- c. YOU ACKNOWLEDGE AND AGREE THAT TI SHALL NOT BE LIABLE FOR AND SHALL NOT DEFEND OR INDEMNIFY YOU AGAINST ANY THIRD PARTY INFRINGEMENT CLAIM THAT RELATES TO OR IS BASED ON YOUR MANUFACTURE, USE, OR DISTRIBUTION OF THE LICENSED MATERIALS OR YOUR MANUFACTURE, USE, OFFER FOR SALE, SALE, IMPORTATION OR DISTRIBUTION OF YOUR PRODUCTS THAT INCLUDE OR INCORPORATE THE LICENSED MATERIALS.
- d. You acknowledge and agree that you are responsible for any fees or royalties that may be payable to any third party based on such third party's interests in the Licensed Materials described in Section 3(b) above (the "Third Party Payment Obligations"). You agree to indemnify TI against any Third Party Payment Obligations and will defend any claim, suit or proceeding brought against TI insofar as such claim, suit or proceeding is based on your failure to pay any Third Party Payment Obligations.

4. Warranties and Limitations. THE LICENSED MATERIALS ARE PROVIDED "AS IS". TI AND ITS LICENSORS MAKE NO WARRANTY OR REPRESENTATION, EXPRESS, IMPLIED OR STATUTORY, INCLUDING ANY IMPLIED WARRANTIES OF MERCHANTABILITY, FITNESS FOR A PARTICULAR PURPOSE, LACK OF VIRUSES, ACCURACY OR COMPLETENESS OF RESPONSES, RESULTS AND LACK OF NEGLIGENCE. TI DISCLAIMS ANY WARRANTY OF TITLE, QUIET ENJOYMENT, QUIET POSSESSION, AND NON-INFRINGEMENT OF ANY THIRD PARTY INTELLECTUAL PROPERTY RIGHTS WITH REGARD TO THE LICENSED MATERIALS OR USE OF THOSE MATERIALS.

YOU ACKNOWLEDGE AND AGREE THAT THE LICENSED MATERIALS MAY NOT BE INTENDED FOR PRODUCTION APPLICATIONS AND MAY CONTAIN IRREGULARITIES AND DEFECTS NOT FOUND IN PRODUCTION SOFTWARE. FURTHERMORE, YOU ACKNOWLEDGE AND AGREE THAT THE LICENSED MATERIALS HAVE NOT BEEN TESTED OR CERTIFIED BY ANY GOVERNMENT AGENCY OR INDUSTRY REGULATORY ORGANIZATION OR ANY OTHER THIRD PARTY ORGANIZATION. YOU AGREE THAT PRIOR TO USING, INCORPORATING OR DISTRIBUTING THE LICENSED MATERIALS IN OR WITH ANY COMMERCIAL PRODUCT THAT YOU WILL THOROUGHLY TEST THE PRODUCT AND THE FUNCTIONALITY OF THE LICENSED MATERIALS IN OR WITH THAT PRODUCT AND BE SOLELY RESPONSIBLE FOR ANY PROBLEMS OR FAILURES.

IN NO EVENT SHALL TI OR ITS LICENSORS BE LIABLE FOR ANY SPECIAL, INDIRECT, INCIDENTAL, PUNITIVE OR CONSEQUENTIAL DAMAGES, HOWEVER CAUSED ON ANY THEORY OF LIABILITY, ARISING IN ANY WAY OUT OF THIS AGREEMENT, OR YOUR USE OF THE LICENSED MATERIALS, WHETHER OR NOT TI HAS BEEN ADVISED OF THE POSSIBILITY OF SUCH DAMAGES. EXCLUDED DAMAGES INCLUDE, BUT ARE NOT LIMITED TO, COST OF REMOVAL OR REINSTALLATION, OUTSIDE COMPUTER TIME, LABOR COSTS, LOSS OR CORRUPTION OF DATA, LOSS OF GOODWILL, LOSS OF PROFITS, LOSS OF SAVINGS, OR LOSS OF USE OR INTERRUPTION OF BUSINESS OR ANY OTHER ECONOMIC LOSS. IN NO EVENT WILL TI'S AGGREGATE LIABILITY UNDER THIS AGREEMENT OR ARISING OUT OF YOUR USE OF THE LICENSED MATERIALS EXCEED FIVE HUNDRED U.S. DOLLARS (US\$500).

Because some jurisdictions do not allow the exclusion or limitation of incidental or consequential damages or limitation on how long an implied warranty lasts, the above limitations or exclusions may not apply to you.

5. Export Control. The Licensed Materials may be subject to the export or import regulations of certain countries. You agree to comply with all such regulations and acknowledge that you have the responsibility to obtain any licenses or other authorizations that may be required to export, re-export or import the Licensed Materials.
6. Governing Law, Jurisdiction and Severability. This Agreement will be governed by and interpreted in accordance with the laws of the State of Texas, without reference to conflict of laws principles. If for any reason a court of competent jurisdiction finds any provision of the Agreement to be unenforceable, that provision will be enforced to the maximum extent possible to effectuate the intent of the parties and the remainder of the Agreement shall continue in full force and effect. This Agreement shall not be governed by the United Nations Convention on Contracts for the International Sale of Goods, or by the Uniform Computer Information Transactions Act (UCITA). The parties agree that non-exclusive jurisdiction for any dispute arising out of or relating to this Agreement lies within the courts located in the State of Texas. Notwithstanding the foregoing, any judgment may be enforced in any United States or foreign court, and either party may seek injunctive relief in any United States or foreign court. Failure by TI to enforce any provision of this Agreement shall not be deemed a waiver of future enforcement of that or any other provision in this Agreement or any other agreement that may be in place between the parties.

7. PRC Provisions. If you are located in the People's Republic of China ("PRC") or if the Licensed Materials will be sent to the PRC, the following provisions shall apply:
- a. Registration Requirements. You shall be solely responsible for performing all acts and obtaining all approvals that may be required in connection with this Agreement by the government of the PRC, including but not limited to registering pursuant to, and otherwise complying with, the PRC Measures on the Administration of Software Products, Management Regulations on Technology Import-Export, and Technology Import and Export Contract Registration Management Rules. Upon receipt of such approvals from the government authorities, you shall forward evidence of all such approvals to TI for its records. In the event that you fail to obtain any such approval or registration, you shall be solely responsible for any and all losses, damages or costs resulting therefrom, and shall indemnify TI for all such losses, damages or costs.
 - b. Governing Language. This Agreement is written and executed in the English language. If a translation of this Agreement is required for any purpose, including but not limited to registration of the Agreement pursuant to any governmental laws, regulations or rules, you shall be solely responsible for creating such translation. Any translation of this Agreement into a language other than English is intended solely in order to comply with such laws or for reference purposes, and the English language version shall be authoritative and controlling.
8. Entire Agreement. This is the entire agreement between you and TI and supersedes any prior agreement between the parties related to the subject matter of this Agreement. No amendment or modification of this Agreement will be effective unless in writing and signed by a duly authorized representative of TI. You hereby warrant and represent that you have obtained all authorizations and other applicable consents required empowering you to enter into this Agreement.

ZLib License

zlib.h -- interface of the 'zlib' general purpose compression library

Copyright (C) 1995-2005 Jean-loup Gailly and Mark Adler

This software is provided 'as-is', without any express or implied warranty. In no event will the authors be held liable for any damages arising from the use of this software.

Permission is granted to anyone to use this software for any purpose, including commercial applications, and to alter it and redistribute it freely, subject to the following restrictions:

1. The origin of this software must not be misrepresented; you must not claim that you wrote the original software. If you use this software in a product, an acknowledgment in the product documentation would be appreciated but is not required.
2. Altered source versions must be plainly marked as such, and must not be misrepresented as being the original software.
3. This notice may not be removed or altered from any source distribution.

Jean-loup Gailly Mark Adler
 jloup@gzip.org madler@alumni.caltech.edu

The data format used by the zlib library is described by RFCs (Request for Comments) 1950 to 1952 in the files <http://www.ietf.org/rfc/rfc1950.txt> (zlib format), [rfc1951.txt](http://www.ietf.org/rfc/rfc1951.txt) (deflate format) and [rfc1952.txt](http://www.ietf.org/rfc/rfc1952.txt) (gzip format).

TOPCON CORPORATION (Manufacturer)

75-1 Hasunuma-cho, Itabashi-ku, Tokyo 174-8580, Japan <https://www.topcon.co.jp>

Please see the following website for contact addresses.

GLOBAL GATEWAY <https://global.topcon.com>
